



Bid Number/बोली क्रमांक (बिड संख्या):
GEM/2024/B/5151303
Dated/दिनांक : 11-07-2024

Bid Document/ बिड दस्तावेज़

Bid Details/बिड विवरण	
Bid End Date/Time/बिड बंद होने की तारीख/समय	25-07-2024 17:00:00
Bid Opening Date/Time/बिड खुलने की तारीख/समय	25-07-2024 17:30:00
Bid Offer Validity (From End Date)/बिड पेशकश वैधता (बंद होने की तारीख से)	180 (Days)
Ministry/State Name/मंत्रालय/राज्य का नाम	Ministry Of Water Resources River Development And Ganga Rejuvenation
Department Name/विभाग का नाम	Wapcos Limited
Organisation Name/संगठन का नाम	Wapcos Limited
Office Name/कार्यालय का नाम	Wapcos Limited
Total Quantity/कुल मात्रा	1186
Item Category/मद केटेगरी	Single Bed , Vistor Chair , Study Table , King Size Bed , Bed Side Table , Visitor Chair , 2 Seater Sofa , Coffee Table , Reception Desk , 3 Seater Sofa , 1 Seater Sofa , Center Table , Revolving chair , 6 Seater Dining Table , Dining Chair as per tender document
BOQ Title/बीओक्यू शीर्षक	BOQBOQ
Minimum Average Annual Turnover of the bidder (For 3 Years)/बिडर का न्यूनतम औसत वार्षिक टर्नओवर (3 वर्षों का)	78 Lakh (s)
OEM Average Turnover (Last 3 Years)/मूल उपकरण निर्माता का औसत टर्नओवर (गत 3 वर्षों का)	630 Lakh (s)
Years of Past Experience Required for same/similar service/उन्हीं/समान सेवाओं के लिए अपेक्षित विगत अनुभव के वर्ष	3 Year (s)
MSE Exemption for Years of Experience and Turnover/ अनुभव के वर्षों से एमएसई छूट	No
Startup Exemption for Years of Experience and Turnover/ अनुभव के वर्षों से स्टार्टअप छूट	No

Bid Details/बिड विवरण	
Document required from seller/विक्रेता से मांगे गए दस्तावेज़	Experience Criteria,Past Performance,Bidder Turnover,Certificate (Requested in ATC),OEM Authorization Certificate,OEM Annual Turnover,Additional Doc 1 (Requested in ATC),Additional Doc 2 (Requested in ATC),Additional Doc 3 (Requested in ATC),Additional Doc 4 (Requested in ATC),Compliance of BoQ specification and supporting document *In case any bidder is seeking exemption from Experience / Turnover Criteria, the supporting documents to prove his eligibility for exemption must be uploaded for evaluation by the buyer
Past Performance/विगत प्रदर्शन	80 %
Bid to RA enabled/बिड से रिवर्स नीलामी सक्रिय किया	No
Type of Bid/बिड का प्रकार	Two Packet Bid
Primary product category	Single Bed
Time allowed for Technical Clarifications during technical evaluation/तकनीकी मूल्यांकन के दौरान तकनीकी स्पष्टीकरण हेतु अनुमत समय	5 Days
Inspection Required (By Empanelled Inspection Authority / Agencies pre-registered with GeM)	No
Estimated Bid Value/अनुमानित बिड मूल्य	15766853
Evaluation Method/मूल्यांकन पद्धति	Total value wise evaluation
Financial Document Required/वित्तीय दस्तावेज़ की आवश्यकता है।	Yes

EMD Detail/ईएमडी विवरण

Advisory Bank/एडवाइजरी बैंक	State Bank of India
EMD Amount/ईएमडी राशि	315000

ePBG Detail/ईपीबीजी विवरण

Required/आवश्यकता	No
-------------------	----

(a). EMD EXEMPTION: The bidder seeking EMD exemption, must submit the valid supporting document for the relevant category as per GeM GTC with the bid. Under MSE category, only manufacturers for goods and Service Providers for Services are eligible for exemption from EMD. Traders are excluded from the purview of this Policy./जेम की शर्तों के अनुसार ईएमडी छूट के इच्छुक बिडर को संबंधित कैटेगरी के लिए बिड के साथ वैध समर्थित दस्तावेज़ प्रस्तुत करने हैं। एमएसई कैटेगरी के अंतर्गत केवल वस्तुओं के लिए विनिर्माता तथा सेवाओं के लिए सेवा प्रदाता ईएमडी से छूट के पात्र हैं। व्यापारियों को इस नीति के दायरे से बाहर रखा गया है।

(b). EMD & Performance security should be in favour of Beneficiary, wherever it is applicable./ईएमडी और संपादन जमानत राशि, जहां यह लागू होती है, लाभार्थी के पक्ष में होनी चाहिए।

Beneficiary/लभार्थी :

WAPCOS LIMITED
WAPCOS Limited, 76-C, Institution Area, Sector-18, Gurugram, Haryana-122015
(Wapcos Limited)

Splitting/विभाजन

Bid splitting not applied/बोली विभाजन लागू नहीं किया गया.

MII Purchase Preference/एमआईआई खरीद वरीयता

MII Purchase Preference/एमआईआई खरीद वरीयता	Yes
--	-----

MSE Purchase Preference/एमएसई खरीद वरीयता

MSE Purchase Preference/एमएसई खरीद वरीयता	Yes
---	-----

1. The minimum average annual financial turnover of the bidder during the last three years, ending on 31st March of the previous financial year, should be as indicated above in the bid document. Documentary evidence in the form of certified Audited Balance Sheets of relevant periods or a certificate from the Chartered Accountant / Cost Accountant indicating the turnover details for the relevant period shall be uploaded with the bid. In case the date of constitution / incorporation of the bidder is less than 3-year-old, the average turnover in respect of the completed financial years after the date of constitution shall be taken into account for this criteria.
2. Experience Criteria: In respect of the filter applied for experience criteria, the Bidder or its OEM {themselves or through reseller(s)} should have regularly, manufactured and supplied same or similar Category Products to any Central / State Govt Organization / PSU for number of Financial years as indicated above in the bid document before the bid opening date. Copies of relevant contracts to be submitted along with bid in support of having supplied some quantity during each of the Financial year. In case of bunch bids, the category of primary product having highest value should meet this criterion.
3. OEM Turn Over Criteria: The minimum average annual financial turnover of the OEM of the offered product during the last three years, ending on 31st March of the previous financial year, should be as indicated in the bid document. Documentary evidence in the form of certified Audited Balance Sheets of relevant periods or a certificate from the Chartered Accountant / Cost Accountant indicating the turnover details for the relevant period shall be uploaded with the bid. In case the date of constitution / incorporation of the OEM is less than 3 year old, the average turnover in respect of the completed financial years after the date of constitution shall be taken into account for this criteria.
4. Preference to Make In India products (For bids < 200 Crore):Preference shall be given to Class 1 local supplier as defined in public procurement (Preference to Make in India), Order 2017 as amended from time to time and its subsequent Orders/Notifications issued by concerned Nodal Ministry for specific Goods/Products. The minimum local content to qualify as a Class 1 local supplier is denoted in the bid document. If the bidder wants to avail the Purchase preference, the bidder must upload a certificate from the OEM regarding the percentage of the local content and the details of locations at which the local value addition is made along with their bid, failing which no purchase preference shall be granted. In case the bid value is more than Rs 10 Crore, the declaration relating to percentage of local content shall be certified by the statutory auditor or cost auditor, if the OEM is a company and by a practicing cost accountant or a chartered accountant for OEMs other than companies as per the Public Procurement (preference to Make-in -India) order 2017 dated 04.06.2020. Only Class-I and Class-II Local suppliers as per MII order dated 4.6.2020 will be eligible to bid. Non - Local suppliers as per MII order dated 04.06.2020 are not eligible to participate. However, eligible micro and small enterprises will be allowed to participate .The buyers are advised to refer the OM No.F.1/4/2021-PPD dated 18.05.2023.
[OM No.1 4 2021 PPD dated 18.05.2023](#) for compliance of Concurrent application of Public Procurement Policy for Micro and Small Enterprises Order, 2012 and Public Procurement (Preference to Make in India) Order, 2017.
5. Purchase preference will be given to MSEs having valid Udyam Registration and whose credentials are validated online through Udyam Registration portal as defined in Public Procurement Policy for Micro and Small

Enterprises (MSEs) Order, 2012 dated 23.03.2012 issued by Ministry of Micro, Small and Medium Enterprises and its subsequent Orders/Notifications issued by concerned Ministry. If the bidder wants to avail themselves of the Purchase preference, the bidder must be the manufacturer / OEM of the offered product on GeM. Traders are excluded from the purview of Public Procurement Policy for Micro and Small Enterprises and hence resellers offering products manufactured by some other OEM are not eligible for any purchase preference. In respect of bid for Services, the bidder must be the Service provider of the offered Service. Relevant documentary evidence in this regard shall be uploaded along with the bid in respect of the offered product or service and Buyer will decide eligibility for purchase preference based on documentary evidence submitted, while evaluating the bid. If L-1 is not an MSE and MSE Seller (s) has / have quoted price within L-1+ 15% (Selected by Buyer) of margin of purchase preference /price band defined in relevant policy, such MSE Seller shall be given opportunity to match L-1 price and contract will be awarded for 25% (selected by Buyer) percentage of total quantity. The buyers are advised to refer the OM No. F.1/4/2021-PPD dated 18.05.2023 [OM No.1 4 2021 PPD dated 18.05.2023](#) for compliance of Concurrent application of Public Procurement Policy for Micro and Small Enterprises Order, 2012 and Public Procurement (Preference to Make in India) Order, 2017. Benefits of MSE will be allowed only if seller is validated on-line in GeM profile as well as validated and approved by Buyer after evaluation of documents submitted.

6. Estimated Bid Value indicated above is being declared solely for the purpose of guidance on EMD amount and for determining the Eligibility Criteria related to Turn Over, Past Performance and Project / Past Experience etc. This has no relevance or bearing on the price to be quoted by the bidders and is also not going to have any impact on bid participation. Also this is not going to be used as a criteria in determining reasonableness of quoted prices which would be determined by the buyer based on its own assessment of reasonableness and based on competitive prices received in Bid / RA process.

7. Past Performance: The Bidder or its OEM {themselves or through re-seller(s)} should have supplied same or similar Category Products for 80% of bid quantity, in at least one of the last three Financial years before the bid opening date to any Central / State Govt Organization / PSU. Copies of relevant contracts (proving supply of cumulative order quantity in any one financial year) to be submitted along with bid in support of quantity supplied in the relevant Financial year. In case of bunch bids, the category related to primary product having highest bid value should meet this criterion.

Pre Bid Detail(s)

Pre-Bid Date and Time	Pre-Bid Venue
16-07-2024 14:00:00	Sr. General Manager, WAPCOS Limited Construction Management Unit-I, 1 st floor, NPCC Building Plot no. 148, Sector-44, Gurugram

Single Bed

(Minimum 50% and 20% Local Content required for qualifying as Class 1 and Class 2 Local Supplier respectively/क्रमशः श्रेणी 1 और श्रेणी 2 के स्थानीय आपूर्तिकर्ता के रूप में अर्हता प्राप्त करने के लिए आवश्यक)

Technical Specifications/तकनीकी विशिष्टियाँ

Specification Document	View File
BOQ Detail Document	View File

Advisory-Please refer attached BOQ document for detailed consignee list and delivery period.

Consignees/Reporting Officer/परेषिती/रिपोर्टिंग अधिकारी and/ तथा Quantity/मात्रा

S.No./क्र. सं.	Consignee Reporting/Officer/ परेषिती/रिपोर्टिंग अधिकारी	Address/पता	Quantity/मात्रा	Delivery Days/डिलीवरी के दिन
1	Arun Kumar Baindara	122003,NPCC Building 1st Floor ,Plot No.148 Sec-44	318	45

Vistor Chair

(Minimum 50% and 20% Local Content required for qualifying as Class 1 and Class 2 Local Supplier respectively/क्रमशः श्रेणी 1 और श्रेणी 2 के स्थानीय आपूर्तिकर्ता के रूप में अर्हता प्राप्त करने के लिए आवश्यक)

Technical Specifications/तकनीकी विशिष्टियाँ

Specification Document	View File
BOQ Detail Document	View File

Advisory-Please refer attached BOQ document for detailed consignee list and delivery period.

Consignees/Reporting Officer/परेषिती/रिपोर्टिंग अधिकारी and/ तथा Quantity/मात्रा

S.No./क्र. सं.	Consignee Reporting/Officer/ परेषिती/रिपोर्टिंग अधिकारी	Address/पता	Quantity/मात्रा	Delivery Days/डिलीवरी के दिन
1	Arun Kumar Baindara	122003,NPCC Building 1st Floor ,Plot No.148 Sec-44	312	45

Study Table

(Minimum 50% and 20% Local Content required for qualifying as Class 1 and Class 2 Local Supplier respectively/क्रमशः श्रेणी 1 और श्रेणी 2 के स्थानीय आपूर्तिकर्ता के रूप में अर्हता प्राप्त करने के लिए आवश्यक)

Technical Specifications/तकनीकी विशिष्टियाँ

Specification Document	View File
BOQ Detail Document	View File

Advisory-Please refer attached BOQ document for detailed consignee list and delivery period.

Consignees/Reporting Officer/परेषिती/रिपोर्टिंग अधिकारी and/ तथा Quantity/मात्र

S.No./क्र. सं.	Consignee Reporting/Officer/ परेषिती/रिपोर्टिंग अधिकारी	Address/पता	Quantity/मात्र	Delivery Days/डिलीवरी के दिन
1	Arun Kumar Baidara	122003,NPCC Building 1st Floor ,Plot No.148 Sec-44	312	45

King Size Bed

(Minimum 50% and 20% Local Content required for qualifying as Class 1 and Class 2 Local Supplier respectively/क्रमशः श्रेणी 1 और श्रेणी 2 के स्थानीय आपूर्तिकर्ता के रूप में अर्हता प्राप्त करने के लिए आवश्यक)

Technical Specifications/तकनीकी विशिष्टियाँ

Specification Document	View File
BOQ Detail Document	View File

Advisory-Please refer attached BOQ document for detailed consignee list and delivery period.

Consignees/Reporting Officer/परेषिती/रिपोर्टिंग अधिकारी and/ तथा Quantity/मात्र

S.No./क्र. सं.	Consignee Reporting/Officer/ परेषिती/रिपोर्टिंग अधिकारी	Address/पता	Quantity/मात्र	Delivery Days/डिलीवरी के दिन
1	Arun Kumar Baidara	122003,NPCC Building 1st Floor ,Plot No.148 Sec-44	18	45

Bed Side Table

(Minimum 50% and 20% Local Content required for qualifying as Class 1 and Class 2 Local Supplier respectively/क्रमशः श्रेणी 1 और श्रेणी 2 के स्थानीय आपूर्तिकर्ता के रूप में अर्हता प्राप्त करने के लिए आवश्यक)

Technical Specifications/तकनीकी विशिष्टियाँ

Specification Document	View File
BOQ Detail Document	View File

Advisory-Please refer attached BOQ document for detailed consignee list and delivery period.

Consignees/Reporting Officer/परेषिती/रिपोर्टिंग अधिकारी and/ तथा Quantity/मात्र

S.No./क्र. सं.	Consignee Reporting/Officer/ परेषिती/रिपोर्टिंग अधिकारी	Address/पता	Quantity/मात्र	Delivery Days/डिलीवरी के दिन
1	Arun Kumar Baidara	122003,NPCC Building 1st Floor ,Plot No.148 Sec-44	18	45

Study Table

(Minimum 50% and 20% Local Content required for qualifying as Class 1 and Class 2 Local Supplier respectively/क्रमशः श्रेणी 1 और श्रेणी 2 के स्थानीय आपूर्तिकर्ता के रूप में अर्हता प्राप्त करने के लिए आवश्यक)

Technical Specifications/तकनीकी विशिष्टियाँ

Specification Document	View File
BOQ Detail Document	View File

Advisory-Please refer attached BOQ document for detailed consignee list and delivery period.

Consignees/Reporting Officer/परेषिती/रिपोर्टिंग अधिकारी and/ तथा Quantity/मात्र

S.No./क्र. सं.	Consignee Reporting/Officer/ परेषिती/रिपोर्टिंग अधिकारी	Address/पता	Quantity/मात्रा	Delivery Days/डिलीवरी के दिन
1	Arun Kumar Baindara	122003,NPCC Building 1st Floor ,Plot No.148 Sec-44	18	45

Visitor Chair

(Minimum 50% and 20% Local Content required for qualifying as Class 1 and Class 2 Local Supplier respectively/क्रमशः श्रेणी 1 और श्रेणी 2 के स्थानीय आपूर्तिकर्ता के रूप में अर्हता प्राप्त करने के लिए आवश्यक)

Technical Specifications/तकनीकी विशिष्टियाँ

Specification Document	View File
BOQ Detail Document	View File

Advisory-Please refer attached BOQ document for detailed consignee list and delivery period.

Consignees/Reporting Officer/परेषिती/रिपोर्टिंग अधिकारी and/ तथा Quantity/मात्रा

S.No./क्र. सं.	Consignee Reporting/Officer/ परेषिती/रिपोर्टिंग अधिकारी	Address/पता	Quantity/मात्रा	Delivery Days/डिलीवरी के दिन
1	Arun Kumar Baindara	122003,NPCC Building 1st Floor ,Plot No.148 Sec-44	18	45

2 Seater Sofa

(Minimum 50% and 20% Local Content required for qualifying as Class 1 and Class 2 Local Supplier respectively/क्रमशः श्रेणी 1 और श्रेणी 2 के स्थानीय आपूर्तिकर्ता के रूप में अर्हता प्राप्त करने के लिए आवश्यक)

Technical Specifications/तकनीकी विशिष्टियाँ

Specification Document	View File
BOQ Detail Document	View File

Advisory-Please refer attached BOQ document for detailed consignee list and delivery period.

Consignees/Reporting Officer/परेषिती/रिपोर्टिंग अधिकारी and/ तथा Quantity/मात्र

S.No./क्र. सं.	Consignee Reporting/Officer/ परेषिती/रिपोर्टिंग अधिकारी	Address/पता	Quantity/मात्र	Delivery Days/डिलीवरी के दिन
1	Arun Kumar Baidara	122003,NPCC Building 1st Floor ,Plot No.148 Sec-44	18	45

Coffee Table

(Minimum 50% and 20% Local Content required for qualifying as Class 1 and Class 2 Local Supplier respectively/क्रमशः श्रेणी 1 और श्रेणी 2 के स्थानीय आपूर्तिकर्ता के रूप में अर्हता प्राप्त करने के लिए आवश्यक)

Technical Specifications/तकनीकी विशिष्टियाँ

Specification Document	View File
BOQ Detail Document	View File

Advisory-Please refer attached BOQ document for detailed consignee list and delivery period.

Consignees/Reporting Officer/परेषिती/रिपोर्टिंग अधिकारी and/ तथा Quantity/मात्र

S.No./क्र. सं.	Consignee Reporting/Officer/ परेषिती/रिपोर्टिंग अधिकारी	Address/पता	Quantity/मात्र	Delivery Days/डिलीवरी के दिन
1	Arun Kumar Baidara	122003,NPCC Building 1st Floor ,Plot No.148 Sec-44	18	45

Reception Desk

(Minimum 50% and 20% Local Content required for qualifying as Class 1 and Class 2 Local Supplier respectively/क्रमशः श्रेणी 1 और श्रेणी 2 के स्थानीय आपूर्तिकर्ता के रूप में अर्हता प्राप्त करने के लिए आवश्यक)

Technical Specifications/तकनीकी विशिष्टियाँ

Specification Document	View File
BOQ Detail Document	View File

Advisory-Please refer attached BOQ document for detailed consignee list and delivery period.

Consignees/Reporting Officer/परेषिती/रिपोर्टिंग अधिकारी and/ तथा Quantity/मात्रा

S.No./क्र. सं.	Consignee Reporting/Officer/ परेषिती/रिपोर्टिंग अधिकारी	Address/पता	Quantity/मात्रा	Delivery Days/डिलीवरी के दिन
1	Arun Kumar Baindara	122003,NPCC Building 1st Floor ,Plot No.148 Sec-44	1	45

3 Seater Sofa

(Minimum 50% and 20% Local Content required for qualifying as Class 1 and Class 2 Local Supplier respectively/क्रमशः श्रेणी 1 और श्रेणी 2 के स्थानीय आपूर्तिकर्ता के रूप में अर्हता प्राप्त करने के लिए आवश्यक)

Technical Specifications/तकनीकी विशिष्टियाँ

Specification Document	View File
BOQ Detail Document	View File

Advisory-Please refer attached BOQ document for detailed consignee list and delivery period.

Consignees/Reporting Officer/परेषिती/रिपोर्टिंग अधिकारी and/ तथा Quantity/मात्रा

S.No./क्र. सं.	Consignee Reporting/Officer/ परेषिती/रिपोर्टिंग अधिकारी	Address/पता	Quantity/मात्रा	Delivery Days/डिलीवरी के दिन
1	Arun Kumar Baindara	122003,NPCC Building 1st Floor ,Plot No.148 Sec-44	2	45

1 Seater Sofa

(Minimum 50% and 20% Local Content required for qualifying as Class 1 and Class 2 Local Supplier respectively/क्रमशः श्रेणी 1 और श्रेणी 2 के स्थानीय आपूर्तिकर्ता के रूप में अर्हता प्राप्त करने के लिए आवश्यक)

Technical Specifications/तकनीकी विशिष्टियाँ

Specification Document	View File
BOQ Detail Document	View File

Advisory-Please refer attached BOQ document for detailed consignee list and delivery period.

Consignees/Reporting Officer/परेषिती/रिपोर्टिंग अधिकारी and/ तथा Quantity/मात्रा

S.No./क्र. सं.	Consignee Reporting/Officer/ परेषिती/रिपोर्टिंग अधिकारी	Address/पता	Quantity/मात्रा	Delivery Days/डिलीवरी के दिन
1	Arun Kumar Baidara	122003,NPCC Building 1st Floor ,Plot No.148 Sec-44	4	45

Center Table

(Minimum 50% and 20% Local Content required for qualifying as Class 1 and Class 2 Local Supplier respectively/क्रमशः श्रेणी 1 और श्रेणी 2 के स्थानीय आपूर्तिकर्ता के रूप में अर्हता प्राप्त करने के लिए आवश्यक)

Technical Specifications/तकनीकी विशिष्टियाँ

Specification Document	View File
BOQ Detail Document	View File

Advisory-Please refer attached BOQ document for detailed consignee list and delivery period.

Consignees/Reporting Officer/परेषिती/रिपोर्टिंग अधिकारी and/ तथा Quantity/मात्रा

S.No./क्र. सं.	Consignee Reporting/Officer/ परेषिती/रिपोर्टिंग अधिकारी	Address/पता	Quantity/मात्रा	Delivery Days/डिलीवरी के दिन
1	Arun Kumar Baindara	122003,NPCC Building 1st Floor ,Plot No.148 Sec-44	2	45

Revolving Chair

(Minimum 50% and 20% Local Content required for qualifying as Class 1 and Class 2 Local Supplier respectively/क्रमशः श्रेणी 1 और श्रेणी 2 के स्थानीय आपूर्तिकर्ता के रूप में अर्हता प्राप्त करने के लिए आवश्यक)

Technical Specifications/तकनीकी विशिष्टियाँ

Specification Document	View File
BOQ Detail Document	View File

Advisory-Please refer attached BOQ document for detailed consignee list and delivery period.

Consignees/Reporting Officer/परेषिती/रिपोर्टिंग अधिकारी and/ तथा Quantity/मात्रा

S.No./क्र. सं.	Consignee Reporting/Officer/ परेषिती/रिपोर्टिंग अधिकारी	Address/पता	Quantity/मात्रा	Delivery Days/डिलीवरी के दिन
1	Arun Kumar Baindara	122003,NPCC Building 1st Floor ,Plot No.148 Sec-44	1	45

6 Seater Dining Table

(Minimum 50% and 20% Local Content required for qualifying as Class 1 and Class 2 Local Supplier respectively/क्रमशः श्रेणी 1 और श्रेणी 2 के स्थानीय आपूर्तिकर्ता के रूप में अर्हता प्राप्त करने के लिए आवश्यक)

Technical Specifications/तकनीकी विशिष्टियाँ

Specification Document	View File
BOQ Detail Document	View File

Advisory-Please refer attached BOQ document for detailed consignee list and delivery period.

Consignees/Reporting Officer/परेषिती/रिपोर्टिंग अधिकारी and/ तथा Quantity/मात्र

S.No./क्र. सं.	Consignee Reporting/Officer/ परेषिती/रिपोर्टिंग अधिकारी	Address/पता	Quantity/मात्र	Delivery Days/डिलीवरी के दिन
1	Arun Kumar Baidara	122003,NPCC Building 1st Floor ,Plot No.148 Sec-44	18	45

Dining Chair As Per Tender Document

(Minimum 50% and 20% Local Content required for qualifying as Class 1 and Class 2 Local Supplier respectively/क्रमशः श्रेणी 1 और श्रेणी 2 के स्थानीय आपूर्तिकर्ता के रूप में अर्हता प्राप्त करने के लिए आवश्यक)

Technical Specifications/तकनीकी विशिष्टियाँ

Specification Document	View File
BOQ Detail Document	View File

Advisory-Please refer attached BOQ document for detailed consignee list and delivery period.

Consignees/Reporting Officer/परेषिती/रिपोर्टिंग अधिकारी and/ तथा Quantity/मात्र

S.No./क्र. सं.	Consignee Reporting/Officer/ परेषिती/रिपोर्टिंग अधिकारी	Address/पता	Quantity/मात्र	Delivery Days/डिलीवरी के दिन
1	Arun Kumar Baidara	122003,NPCC Building 1st Floor ,Plot No.148 Sec-44	108	45

Buyer Added Bid Specific Terms and Conditions/क्रेता द्वारा जोड़ी गई बिड की विशेष शर्तें**1. Generic**

OPTION CLAUSE: The Purchaser reserves the right to increase or decrease the quantity to be ordered up to 25 percent of bid quantity at the time of placement of contract. The purchaser also reserves the right to

increase the ordered quantity by up to 25% of the contracted quantity during the currency of the contract at the contracted rates. Bidders are bound to accept the orders accordingly.

2. Buyer Added Bid Specific ATC

Buyer Added text based ATC clauses

Supply, Installation and fixing of furniture location is: Newly Constructed 300 Bedded hostel of Sports Authority of India (SAI) at Lakshmbai National College of Physical Education, Trivandrum, Kerala695581

Disclaimer/अस्वीकरण

The additional terms and conditions have been incorporated by the Buyer after approval of the Competent Authority in Buyer Organization, whereby Buyer organization is solely responsible for the impact of these clauses on the bidding process, its outcome, and consequences thereof including any eccentricity / restriction arising in the bidding process due to these ATCs and due to modification of technical specifications and / or terms and conditions governing the bid. If any clause(s) is / are incorporated by the Buyer regarding following, the bid and resultant contracts shall be treated as null and void and such bids may be cancelled by GeM at any stage of bidding process without any notice:-

1. Definition of Class I and Class II suppliers in the bid not in line with the extant Order / Office Memorandum issued by DPIIT in this regard.
2. Seeking EMD submission from bidder(s), including via Additional Terms & Conditions, in contravention to exemption provided to such sellers under GeM GTC.
3. Publishing Custom / BOQ bids for items for which regular GeM categories are available without any Category item bunched with it.
4. Creating BoQ bid for single item.
5. Mentioning specific Brand or Make or Model or Manufacturer or Dealer name.
6. Mandating submission of documents in physical form as a pre-requisite to qualify bidders.
7. Floating / creation of work contracts as Custom Bids in Services.
8. Seeking sample with bid or approval of samples during bid evaluation process. (However, in bids for [attached categories](#), trials are allowed as per approved procurement policy of the buyer nodal Ministries)
9. Mandating foreign / international certifications even in case of existence of Indian Standards without specifying equivalent Indian Certification / standards.
10. Seeking experience from specific organization / department / institute only or from foreign / export experience.
11. Creating bid for items from irrelevant categories.
12. Incorporating any clause against the MSME policy and Preference to Make in India Policy.
13. Reference of conditions published on any external site or reference to external documents/clauses.
14. Asking for any Tender fee / Bid Participation fee / Auction fee in case of Bids / Forward Auction, as the case may be.

Further, if any seller has any objection/grievance against these additional clauses or otherwise on any aspect of this bid, they can raise their representation against the same by using the Representation window provided in the bid details field in Seller dashboard after logging in as a seller within 4 days of bid publication on GeM. Buyer is duty bound to reply to all such representations and would not be allowed to open bids if he fails to reply to such representations.

[This Bid is also governed by the General Terms and Conditions/ यह बिड सामान्य शर्तों के अंतर्गत भी शासित है](#)

In terms of GeM GTC clause 26 regarding Restrictions on procurement from a bidder of a country which shares a land border with India, any bidder from a country which shares a land border with India will be eligible to bid in this tender only if the bidder is registered with the Competent Authority. While participating in bid, Bidder has to undertake compliance of this and any false declaration and non-compliance of this would be a ground for immediate termination of the contract and further legal action in accordance with the laws./जेम की सामान्य शर्तों के खंड 26 के संदर्भ में भारत के साथ भूमि सीमा साझा करने वाले देश के बिडर से खरीद पर प्रतिबंध के संबंध में भारत के साथ भूमि सीमा साझा करने वाले देश का कोई भी बिडर इस निविदा में बिड देने के लिए तभी पात्र होगा

जब वह बिड देने वाला सक्षम प्राधिकारी के पास पंजीकृत हो।बिड में भाग लेते समय बिडर को इसका अनुपालन करना होगा और कोई भी गलत घोषणा किए जाने व इसका अनुपालन न करने पर अनुबंध को तत्काल समाप्त करने और कानून के अनुसार आगे की कानूनी कार्रवाई का आधार होगा।

---Thank You/धन्यवाद---



TENDER DOCUMENT FOR
Manufacturing, Supply and Installation of Furniture
For 300 Bedded Hostel at SAI, LNCPE Trivandrum

WAP/CMU-I/2024-25/ SAI-TVDR/03

Date: 11/07/2024

Project Management Consultant

WAPCOS LIMITED
1st floor, Plot no. 148, Sector- 44, Gurugram,
Haryana-122015

July, 2024

TABLE OF CONTENT

NOTICE INVITING TENDER (NIT)	
SECTION: I	INSTRUCTIONS TO OEM
SECTION: II	SELECTION AND QUALIFYING CRITERIA
SECTION: III	FORMS
	Letter of Transmittal for Technical Bid and Financial bid
FORM - A	Financial Information
FORM - B	Solvency Certificate
FORM - C	Correspondence Details Of Issuing Authority
FORM - D	Structure & Organization
FORM - E	No Conviction Certificate
FORM - F	No Deviation Certificate
FORM - G	Undertaking Regarding Blacklisting / Non Debarment
FORM - H	Undertaking For Restriction Under Rule 144(XI) Of GFR
FORM - I	Preference To Make In India
FORM – J&J(a)	Format for Performance of works awarded by WAPCOS
FORM – K	Undertaking for owning the Plants & Machineries
SECTION: IV	TERMS OF REFERENCE
SECTION: V	SCOPE OF WORK
SECTION: VI	DRAWINGS AND IMAGES
SECTION: VII	FINANCIAL PROPOSAL

NOTICE INVITING TENDER (NIT)

NOTICE INVITING TENDER (NIT)**WAP/CMU-I/2024-25/ SAI-TVDR/03****Dated : 11/07/2024**

WAPCOS Limited (A Govt. of India Undertaking), for and behalf of Sports Authority of India (SAI) invites “Online Electronic Tenders” on Item Rate Basis from experienced and competent Original Equipment Manufacturer (OEM) meeting prescribed qualifying criteria as mentioned in tender document.

1.	Work	Manufacturing, Supply and Installation of Furniture For 300 Bedded Hostel at SAI, LNCPE Trivandrum
2.	Site / Location	Newly Constructed 300 Bedded hostel of Sports Authority of India (SAI) at Lakshmibai National College of Physical Education, Trivandrum, Kerala-695581
3.	Website for viewing tender, Corrigendum/ Addendum, if any.	www.wapcos.co.in & www.gem.gov.in
4.	Website for Registration/ uploading of Tender	www.gem.gov.in
5.	Estimated / NIT Cost including GST	Rs. 1,57,66,853/-
6.	Earnest Money Deposit (EMD) / Bid Security	Rs. 3.15 Lakhs (Refundable) in the form of D.D./Banker’s cheque/FDR in favors of ‘WAPCOS Limited’ payable at Gurugram, Haryana.
7.	Solvency Certificate	40% of the Estimated cost (i.e. minimum of Rs. 63.07 lakhs). The OEM should submit Original Solvency Certificate issued from a Nationalized/ Scheduled Commercial Bank approved by Reserve Bank of India (RBI). The Certificate should be issued between the publishing of NIT & last date of submission of Bids, including extensions if any and shall be addressed to “WAPCOS Limited, 76-C, Institutional Area, Sector-18, Gurugram, Haryana.
8.	Completion Period	45 days from the Date of Award <ul style="list-style-type: none"> • 0-7 days -Sample preparation at Factory site of OEM • 8-9 days – for factory visit of WAPCOS/ SAI Team for approval of furniture Sample • 10-45 days- Manufacturing, Supply & installation at site Note: Time is critical for this work, hence quote in bid as per the capability of furniture Agency
9.	Bid Validity Period	180 days from the date of opening of Technical bid
10.	Site Visit	OEMs are advised/encouraged to visit the site for actual assessment of size of furniture’s and requirement.
11.	Pre Bid Meeting	16-07-2024 at 14:00 hrs. to be held in the office of Tendering Authority
12.	Last date & time for online submission of Technical & Financial Bid	25-07-2024 up to time as per online GeM Portal

13.	Offline Submission of EMD, Solvency as detail in Tender for OEMs.	25-07-2024 up to 18:00 hours in the office of Tendering Authority
14.	Online opening of Technical Bid	26-07-2024 at 10:00 hrs. in the office of Tendering Authority
15.	Online opening of Financial Bid	Intimated to Technical Qualified OEMs.
16.	Tender Inviting Authority & Communication address during Tendering and Execution of Works	Sr. General Manager, WAPCOS Limited Construction Management Unit-I, 1 st floor, NPCC Building Plot no. 148, Sector-44, Gurugram Email: buildings@wapcos.co.in Contact No. +91124-4488018
17.	The Bid Security/ EMD / Solvency Certificate / BG against Performance Security/ shall be addressed to WAPCOS Corporate Office	WAPCOS Limited 76-C, Institution Area Sector-18, Gurugram, Haryana-122015
<p>Tender fees & EMD are exempted to following:</p> <ol style="list-style-type: none"> 1. <u>Micro and Small Enterprises only</u>, registered with Micro, Small & Medium Enterprises (MSME), on submission of requisite proof in the form of valid certification from MSME. OEMs having annual turnover of Rs. 500 Crore or more, at least in one of the past three completed Financial Years ending FY 2022-23 as per GeM. <p>If the office of WAPCOS Limited, New Delhi happens to be closed on the last date and time mentioned for any of the event, the said event will take place on the next working day at the same time and venue.</p>		

- The tender document has to be viewed/ downloaded from above specified websites. OEMs are advised to visit above specified websites regularly for updates /Amendments/ Corrigendum, if any and not be published elsewhere. The Updates/Corrigendum/Addendum shall be followed up to submission of tender and it will be the part of tender.
- The purpose of this NIT is to provide interested parties with information to assist the preparation of their bid. While WAPCOS Limited has taken due care in the preparation of the information contained herein, and believe it to be complete and accurate, neither it nor any of its authorities or agencies nor any of its respective officers, employees, agents or advisors give any warranty or make any representations, expressed or implied as to the completeness or accuracy of the information contained in this document or any information which may be provided in association with it. The OEMs must read all the terms and conditions of bidding document carefully and only submit the bid, if eligible and in possession of all the documents required. Corrigendum while all efforts have been made to avoid errors in the drafting of the tender documents, the OEM is advised to check the same carefully. No claim on account of any errors detected in the tender documents shall be entertained.
- Further, WAPCOS Limited does not claim that the information is exhaustive. Respondents to this NIT are required to make their own inquiries/ surveys and will be required to confirm, in writing, that they have done so and they did not rely solely on the information in NIT. WAPCOS Limited is not responsible if no due diligence is performed by the OEMs.
- If the office of WAPCOS Limited happens to be closed on the last date and time mentioned for any of the event, the said event will take place on the next working day at the same time and venue.

- WAPCOS Ltd. reserves the right to accept or reject any or all bids without assigning any reasons. No OEM shall have any cause of action or claim against the WAPCOS Ltd. For rejection of his Bid and will not be bound to accept the lowest or any other tender.
- No reimbursement of cost of any type or on any account will be paid to persons or entities submitting their Bid.
- All information submitted in response to this NIT shall be the property of WAPCOS Limited and it shall be free to use the concept of the same at its will.
- It is hereby declared that WAPCOS is committed to follow the principle of transparency, equity and competitiveness in public procurement. The subject Notice Inviting Tender (NIT) is an invitation to offer made on the condition that the OEM will sign the integrity Agreement, which is an integral part of tender/bid documents, failing which the OEM will stand disqualified from the tendering process and the bid of the OEM would be summarily rejected. This declaration shall form part and parcel of the Integrity Agreement and signing of the same shall be deemed as acceptance and signing of the Integrity Agreement on behalf of the WAPCOS.

**For and on behalf of WAPCOS LIMITED
(Sr. General Manager)**

SECTION– I

INSTRUCTIONS TO OEM

SECTION- I INSTRUCTIONS TO OEMs

1.0 SPECIAL INSTRUCTIONS TO OEMs FOR E-TENDERING

OEM shall follow the standard guidelines of e-tendering on **GeM Portal**. **OEM may visit the link <https://gem.gov.in> for participation in the bid.**

E-mail id: helpdesk-gem@gov.in

Toll Free Numbers (Inbound):

Call 1800-419-3436 / 1800-102-3436

2.0 INSTRUCTIONS TO OEM

The purpose of these instructions to serve as a guide to OEMs for preparing offer for carrying out the work in all respect.

- a) Submission of a tender by a OEM implies that the OEM has read Each Section of Tender Document, Corrigendum, Addendum and other related correspondence and has made himself aware about the complete scope of work under the tender document. Accordingly, Contract shall be governed by each Section of Tender Document and all other Conditions mentioned in the tender documents.
- b) WAPCOS Limited desires that the OEMs, under the Work, observe the highest standard of ethics during the performance, procurement and execution of such contracts. In pursuance of this requirement, WAPCOS Limited, defines, for the purposes of this provision, the terms set forth below:
 - i. “Corrupt Practice” means the offering, giving, receiving, or soliciting, directly or indirectly, anything of value to influence improperly the actions of another party;
 - ii. “Fraudulent Practice” means any act of submission of forged documentation, or omission, including a misrepresentation, that knowingly or recklessly misleads, or attempts to mislead, a party to obtain a financial or other benefit or to avoid an obligation, or to succeed in a competitive bidding process;
 - iii. “Coercive Practice” means impairing or harming, or threatening to impair or harm, directly or indirectly, any party or the property of the party to influence improperly the actions of a party;
 - iv. “Collusive Practice” means an arrangement between two or more parties designed to achieve an improper purpose, including influencing improperly the actions of another party.

Will reject the award of Contract, even at a later stage, if it determines that the OEM recommended/ selected for award/awarded has, directly or through an agent, engaged in Corrupt, Fraudulent, Collusive, Or Coercive Practices in competing for the Contract;

The OEM must obtain for himself on his own responsibility and at his own expenses all the information which may be necessary for the purpose of making a bid and for entering into a contract, must examine the Drawings, must inspect the sites of the work, acquaint himself with all local conditions, means of access to the work, nature of the work and all matters pertaining thereto. WAPCOS Limited will in no case be responsible or liable for those costs, regardless of the conduct or outcome of the bidding process.

- a) All OEMs are hereby explicitly informed that conditional offers or offers with deviations from the Conditions of Contract, the bids not meeting the minimum eligibility criteria, Technical Bids not accompanied with EMD and Tender Document Fees of requisite amount in acceptable format, Bids in altered/modified formats, or in deviation with any other requirements stipulated in the tender documents are liable to be rejected.

- b) The Employer reserves the right to waive minor deviations if they do not materially affect the capability of the OEM to perform the contract
- c) The OEMs shall not tamper or modify any part of the tender documents in any manner. In case in part of the bid is found to be tampered or modified at any stage, the bids are liable to be rejected, the contract is liable to be terminated and the full earnest deposit/retention money/performance guarantee will be forfeited and the OEM will be liable to be banned from doing any business with WAPCOS Limited.
- d) Incomplete Price bid shall be liable to be rejected, at the discretion of WAPCOS Limited. The total bid price shall cover the entire scope of works covered in the tender.

3.0 EARNEST MONEY DEPOSIT (EMD) / BID SECURITY

The Earnest Money Deposit shall be as per the details mentioned in NIT. EMD shall not carry any interest. The Bid Security/ EMD of the unsuccessful OEM shall be returned at the earliest after expiry of final bid validity period and latest by 30th days after the award of the contract. Bid Security shall be refunded to the successful OEM on receipt of Performance Security.

The successful OEM shall accept the Letter of Award (LOA) within 15 (Fifteen) days from receipt of the same, failing which the EMD shall be forfeited and the award of work may be liable to be cancelled.

If any OEM withdraws or make any changes in his offer already submitted before the expiry of the validity period or any extension thereof without the written consent of the Employer, the EMD amount will be forfeited for such act of the OEM.

WAPCOS Limited reserves the right of forfeiture of Earnest Money deposit (EMD) in case of the successful OEM.

- i. After opening of Tender, revokes his tender within the validity period or increases his earlier quoted rates.
- ii. Does not commence the work within the period as per LOA/Contract. In case the LOA/Contract is silent in this regard then within 15 days after award of contract.

The Bid Security will be forfeited in the OEM

- i) withdraws or amends its/ his tender;
- ii) impairs or derogates from the tender in any respect within the period of validity of the tender;
- iii) If the OEM does not accept the correction of his bid price during evaluation; and
- iv) If the successful OEM fails to sign the contract or furnish the required performance security within the specified period.

4.0 LANGUAGE OF BID

The Bid and all related correspondence and documents relating to the Work shall be in English language. Supporting documents and printed literature furnished by the OEM may be in another language provided they are accompanied by an accurate English translation which shall be certified by a qualified translator. Any material that is submitted in a language other than English and which is not accompanied by an accurate English translation will not be considered.

5.0 OEM'S RESPONSIBILITY

The OEM is solely responsible for the details of their Bid and the preparation of bids. In no case shall the WAPCOS be responsible for any part of the tender documents submitted by him. Any Site information given in this tender document is for guidance only. The OEM is advised to visit and examine the Site of works and its surroundings at their cost and obtain for themselves on their own responsibility, all information that may be necessary for preparing the tender and entering into a Contract. Irrespective of whether or not the OEMs have attended the pre-bid meeting, they shall be deemed to have inspected the Site and its surroundings beforehand and

taken into account all relevant factors pertaining to the Site and clarifications/ modifications/ additions given in Pre-Bid meeting or addendum issued in the preparation and submission of the Bid.

The OEM shall bear all costs associated with the preparation and submission of his Bid, and the Employer will in no case be responsible and liable for those costs. WAPCOS Limited shall in no case be responsible or liable for these costs, regardless of the conduct or outcome of the bidding process.

6.0 AMENDMENT OF BID DOCUMENTS

At any time prior to the deadline for submission of bids, the Employer may, for any reason (s), whether at their own initiative or in response to a clarification requested by a prospective OEM, modify the Bidding Documents by the issuance of a corrigendum/ addendum. No modification of Bid shall be permissible after last date of submission, whatever may be the reason. The Employer may at their discretion may extend the deadline for submission of Tender/ Bid, if considered necessary.

Any corrigendum/ addendum thus issued shall be part of the bidding documents. Prospective OEMs shall download the same from the e-portal and submit along with the submission of Bid as token of acceptance.

7.0 BID VALIDITY PERIOD

Bids validity will be as per NIT. In exceptional circumstances, on expiry / prior to expiry of original bid validity period, the WAPCOS may request the successful OEM for a specified extension in the period of validity. A OEM may accept OR refuse the request of extension of validity period. A OEM agreeing Extension of validity period will not be required/nor permitted to modify his bid. In case of refuse of request of extension of validity period tender will be cancelled.

8.0 CURRENCY OF BID

Bid prices shall be quoted in Indian Rupees.

SECTION– II

SELECTION AND QUALIFYING CRITERIA

SECTION-II

SELECTION AND QUALIFYING CRITERIA

1.0 SITE VISIT

The furniture supplied by the OEMs will be best fit in the hostel rooms, studio rooms, dining area, etc. and if any modification is required for best fitting of the furniture, then it shall be done by the OEM at his own cost. Therefore, intending OEM(s) are advised to inspect and examine the hostel building & locations mentioned in NIT where furniture is to be supplied & installed, at his own cost and its surroundings and applicable taxes during transportation and satisfy themselves before submitting their bids so as to see the means of access to the site, contingencies and other circumstances which may influence or affect their bid. The OEM(s) shall be responsible for arranging and maintaining at his own cost all materials, tools & plants, facilities for workers and all other services required for installation of furniture.

A OEM(s) shall be deemed to have full knowledge of the site whether he inspects it or not and no extra charge consequent on any misunderstanding or otherwise shall be allowed. The OEM(s) shall be responsible for arranging and maintaining at his own cost all materials, tools & plants, water, electricity access, facilities for workers and all other services required for executing the work unless otherwise specifically provided for in the contract documents. Submission of a bid by a OEM(s) implies that he has read this notice and all other contract documents and has made himself aware of the scope and specifications of the work to be done and of conditions and rates at which stores, tools and plant, etc. will be issued to him by the Government and local conditions and other factors having a bearing on the execution of the work.

2.0 CLARIFICATION AND PRE-BID MEETING

Prospective OEM requiring any clarification of the bidding documents may notify the Employer via representation of GeM portal only, as per the GeM guidelines. The reply for the queries shall be given on GeM portal. No queries/ clarification shall be entertained on email or any mode of communication.

The intending OEMs should depute their authorized person with authorization letter in original to attend the pre-bid meeting. The pre-bid meeting shall be held at the communication address mentioned in NIT. The Addendum/ Corrigendum/Replies to pre bid queries as per Pre bid meeting, shall be uploaded on e-portal & WAPCOS website.

3.0 QUALIFYING CRITERIA:

The intending OEMs should only submit bid if he considers himself eligible and will be Technically Qualified, if have all the Documents as mentioned below in Table-1: "Documents for Technical Qualification".

Table-1 shall also be considered as "CHECK LIST" for submission of documents. **The OEM will upload all the required documents as per Table-1 on Online Portal along with "check list" on top after proper page numbering.**

The "MANDATORY GUIDELINES" for "Uploading of Technical Bids" and "Submission of Offline Bids" are as below:

A. UPLOADING OF TECHNICAL BIDS

- 1) OEM will arrange & prepare the all required documents as per Table no.-1.
- 2) After that OEM will arrange all these documents serial wise as per order given in Table-1 i.e. S.N: a) to s) below
- 3) After that OEM will put continuous page number (without any break) on each page.
- 4) These page numbers shall be written by OEM in “Check List” again each required documents
- 5) This numbered check list prepared by OEM shall be put on top of arranged numbered documents as per above Sno.2.
- 6) After that Authorized representative of OEM shall Sign & Stamp on each page of these arranged numbered documents.
- 7) The numbered Check List along with required Qualifying Documents arranged as per above Sno-1 to 6 shall be scanned in coloured by OEM and will be uploaded Online for ease of “Technical Evaluation”. If file size is increasing these documents may be split in parts, however serial / order will be kept as per above Sno. 2 & 3 for ease of “Technical Evaluation”

Note: There is no need of add any other additional documents apart from the documents asked in Table-1, as additional documents will not be considered during Technical Evaluation

B. SUBMISSION OF OFFLINE DOCUMENTS

The OEM will submit following offline documents in original as per the date prescribed in the NIT.

- EMD (Earnest Money Demand)
- Solvency Certificate

Note: if OEM not follow the above Guidelines, then bid may be rejected by WAPCOS

**Table -1: Documents for Technical Qualification
CHECK LIST**

Name of OEM M/s.....
Name of Work: Manufacturing, Supply and Installation of Furniture for 300 Bedded Hostel at SAI, LNCPE Trivandrum

S. N	Particular of Document	Page Nos. (from – to)	WAPCOS Remarks	
			Yes	No
a)	EMD Documents.			
b)	<p>OEM shall submit “Financial Information” regarding Turnover, Profit/Loss and Net Worth certificate for Last 5 (five) years ending on the financial year 2022-23 in Form-A duly certified by Statutory Auditor/ Chartered Accountant of the OEM which must carry UDIN (Unique Document Identification Number) which will be verified from ICAI Portal in respect of OEM.</p> <ul style="list-style-type: none"> • Profit / loss (after Tax): The OEM should not have incurred any loss (profit after tax should be positive) in more than two years during last five years ending 2022-23. • Turnover: Average annual financial turnover of OEM/ OEM should be at least Rs. 6.30 crore (400% of the estimated cost as per GeM condition) during the immediate last 3 consecutive financial years ending 2022-23 • Net Worth: Net worth of the OEM should be positive during the last financial year 2022-23 and should not have eroded by more than 30% in last 3 Financial years ending on 2022-23. • OEM shall attach Balance Sheet and Profit & loss Statement, duly audited by Statutory Auditor of the OEM for last 5 (five) years ending on the financial year 2022-23 in support of Form-A <p>Note: This Certificate will be verified through ICAI Portal using UDIN number mentioned in Form-A</p> <p>Note: There is no need to upload entire voluminous balance sheet. However, summarized balance sheet (Audited) and summarized Profit & Loss Account (Audited) for last 05 years shall be uploaded.</p>			
c)	<p>Solvency Certificate (40% of estimated cost i.e. minimum of Rs. 63.07 Lakhs).</p> <p>The OEM should not be insolvent, in receivership, bankrupt or being wound up, not have had their business activities suspended. Bank Solvency Certificate issued from a Nationalized / Scheduled Commercial Bank approved by Reserve Bank of India (RBI) should be at least 40% of the estimated cost of the work. The Certificate should be issued between the publishing of NIT & last date of submission of Bids, including extensions if any and shall be addressed to WAPCOS Limited, 76-C, Institutional Area, Sector-18,</p>			

S. N	Particular of Document	Page Nos. (from – to)	WAPCOS Remarks	
	<p>Gurugram, Haryana <u>specific to this Bid submission only and mentioning the name of the work/project</u> as prescribed in Form-B. The certificate shall be submitted in original and the colour / b&w copy / scanned copy shall not be accepted. The certificate should carry name, designation of the bank official, who has the authority to issue Solvency Certificate</p> <p>Note: This Certificate will be verified from the issuing authority by WAPCOS</p>			
d)	<p>Authority to Sign the Tender</p> <p>a) In case OEM is a proprietary firm, the Proprietor shall sign with full name, current address OR by the authorized person holding Notarized Power of Attorney issued by the Proprietor for signing of business proposal.</p> <p>b) In case OEM is a Limited Company or Corporation, the Application shall be signed by an authorized person holding the Power of Attorney for signing of business proposal. A certified copy of the Power of Attorney shall accompany the Application.</p>			
e)	<p>Letter of Transmittal For Technical Bid and Financial bid along with Declaration by the OEM on OEM's original letter Head as per given format</p>			
f)	<p>Completed Similar Work Criteria:</p> <p>The OEM should have satisfactorily completed the similar types of works of works costing not less than 80% (1.15 crore) of the estimated cost of work during the last Five years ending previous day of last date of submission of tender.</p> <p>Note:</p> <p>Similar work shall mean “Supply and installation of furniture”. The OEM shall submit Completion Certificate(s) mentioning name, nature of work(s), value(s) of the job(s), along-with LOI(s)/W.O(s) from respective Owner(s)/Client(s).</p> <p>For the works, where the Taxes or GST is not clearly defined, the value of works shall be considered as including GST and GST @ 18% to establish the value of work done.</p> <p>The value of executed works shall be brought to the current level by enhancing the actual value of work done at a simple rate of 7% per annum, calculated from the date of completion of last day of the month previous to the one in which applications are invited.</p> <p>For work experience of Private Sector, the completion certificates shall be supported with copies of corresponding TDS certificates.</p> <p>Note: The completion / experience certificates, along with the supporting documents, shall be got verified from the</p>			

S. N	Particular of Document	Page Nos. (from – to)	WAPCOS Remarks	
	issuing authority / organizations prior to opening of Financial Bid. In case the work / certificate are not verified by the issuing authority, WAPCOS reserve the right to not consider the award of work. For work experience of private sector, the completion certificate shall be supported with copies of corresponding TDS certificates. <u>In case of mismatch in value in TDS certificate & completion certificate, then value mentioned in TDS certificate will be considered during evaluation.</u>			
g)	<p>Verification of Solvency Certificate and Completion & Performance Certificates.</p> <p>Verification should be done from the official email id (with Official domain) of issuing Authorities. The OEM will provide official e-mail, Landline number of the Issuing Authorities in prescribed Form-C with undertaking. OEM will ensure the email ids and landline are in working condition.</p> <p>If Solvency Certificate, Completion, Performance Certificates are not verified by the issuing authority, then it may not be considered for technical evaluation.</p>			
h)	<p>GST Registration & PAN:</p> <p>OEM shall submit valid GST registration certificate for the state where work is to be executed and PAN Card. If not registered till date of submission of bid, OEM will give undertaking on OEM letter head stating that they will get registered in GST as per Govt. norms before submitting of 1st bill of executed works.</p>			
i)	<p>Indian Registered Company:</p> <p>The OEM should be an Indian Registered Company under Companies Act 1956/ Proprietorship Firm/ Partnership Firm. Joint ventures are not accepted. Copy of Certificate of Incorporation/ Registration/ Partnership Deed Registration or any other relevant document, as applicable, should be submitted along with a copy of address proof.</p> <p>NOTE: Proprietor firms shall submit registration details or shall submit the copy of relevant page of Pass book for the Current Account in the name of Proprietor Firm or GST Registration Certificate mentioning Company is Proprietary Firm and having trade name in the name of OEM firm.</p>			
j)	<p>Tenderer must be Original Equipment Manufacturer (OEM)</p> <p>The OEM must have their own Manufacturing Unit for manufacturing of furniture as per BoQ and shall submit Factory Registration/ Factory Act license issued by Govt. Authority, proof of manufacturing plant with ownership in the name of OEM Location & address of manufacturing plant and ESIC / EPF registration.</p>			
k)	Structure & Organization:			

S. N	Particular of Document	Page Nos. (from – to)	WAPCOS Remarks	
	The OEM will submit Name, address, details of the organization, Name(s) of the Owner/partners/promoters and Directors of the OEM as prescribed in Form-D .			
l)	ISO Certification: The OEM should have the following certification <ul style="list-style-type: none"> • ISO 9001 - Quality Management System • ISO 14001-Environmental Management System • ISO 45001- Occupational Health & Safety Management System 			
m)	Non - Conviction Certificate: The OEM will submit the undertaking regarding “ Non – Conviction Certificate ” as prescribed in Form-E .			
n)	No Deviation Certificate: The OEM will submit ‘ No Deviation Certificate ’ as prescribed in Form-F .			
o)	Undertaking regarding Blacklisting / Non Debarment The OEM will submit the “Undertaking regarding Blacklisting / Non Debarment” as prescribed in Form-G .			
p)	Undertaking regarding Restriction under Rule 144(XI) The OEM will submit the “Undertaking regarding Restriction under Rule 144(XI) of the General Finance Rules (GFRs) 2017” as prescribed in Form –H .			
q)	Preference to Make in India: The OEM shall submit undertaking indicating percentage of local content used during the execution of work as per the order of Public Procurement (Preference to Make in India) as prescribed in Form-I			
r)	Format for Performance of works awarded by WAPCOS (Completed & Ongoing) (FORM J and J(a))			
s)	Undertaking for owning the Plants & Machineries The OEM will submit the “Undertaking for owning the Plants & Machineries” as prescribed in Form –K for supply of quality furniture			

4.0 MACHINERIES

The OEM who manufactures furniture items through manual cutting, pressing, bending, welding, painting, polishing, stitching, forming shall not be allowed for the bidding. Accordingly, the OEM should have minimum following machinery in its factory/manufacturing unit

- CNC Machine for designer cutting
- Hydraulic CNC tube Bending Machine
- MIG Welding machine
- Laser Cutting Machine
- NC bending Machine
- Powder coating Booth and furnace

5.0 CONTENTS OF FINANCIAL BID

The Financial Bid should be uploaded online before last date & time of submission of Tender Document.

Quoted rates by the OEM shall be firm during the performance of the Contract. Quoted amount by the OEM with any condition shall not be accepted and same is liable to be rejected. Rates quoted by the OEM shall include all Materials, Tools & Plant, labour, supervision, profit; other levies together with all general risks, liabilities and obligations set out or implied in the contract, applicable Labour Cess, cost of insurance to this contract, all applicable tax liabilities like Income Tax & Surcharges, etc. Any other taxes /cess as per Government directives shall be deducted from each bill paid to the OEM, from time to time. GST shall be payable extra as per prevailing rates.

It is mandatory to OEMs to deposit GST within time limit framed by Govt. of India, if applicable. The Goods and Services Tax (GST), shall be reimbursed to the Agency only after uploading of bills by OEM on GST Portal “ to avail Input benefit of GST”.

The OEM shall submit e-invoice / Tax Invoice (as applicable for the OEM's) to WAPCOS showing (i) Basic amount (ii) GST amount separately in each bill. It is mandatory to OEMs to deposit GST within time limit framed by Govt. of India, if applicable. The Goods and Services Tax (GST), shall be reimbursed to the Agency only after uploading of bills by OEM on GST Portal “to avail Input benefit of GST”.

The WAPCOS shall be performing all its duties of deduction TDS and other deduction on payment made to the OEM as per applicable legislation in force on the date of submission of bid or to be newly / amended introduced during the execution of the Contract.

6.0 OPENING OF FINANCIAL BID

The financial bids of the technically qualified OEMs shall be opened at the notified date & time. Final selection of the OEM will be made based on the least cost method.

7.0 SIGNING OF THE CONTRACT

The letter of Award will be issued to the successful OEM by WAPCOS which will be duly signed & stamped by the successful OEM as token of unequivocal acceptance and confirmation within 5 working days. Subsequently, successful OEM shall submit the Performance Security of required value within the specified time period. Thereafter, on a date and time mutually agreed upon, the successful OEM or his authorized representative shall attend the office for signing of the Contract Agreement.

Failure on the part of the successful OEM to comply with the above requirements will constitute sufficient grounds for the annulment of the Award and forfeiture of the Bid Security. The format of signing of agreement and letter of award is enclosed at **Annexure-I**.

ANNEXURE-I**(Format for “Contract” to be signed on Non-Judicial Stamp Paper of Rs. 100 by successful OEM)****CONTRACT AGREEMENT**

This Contract made on the ___ day of ___ 20___ between WAPCOS Limited, a Company in corporate under Indian Company’s Act and having its registered office at 5th floor, Kailash Building, 26, K. G. Marg, New Delhi (hereinafter called “WAPCOS” of the one part) and (Name of OEM & Address)_____ (hereinafter called “OEM” of the other part).

WHEREAS the WAPCOS is desirous that Work known as “_____”. (Herein after referred to as “Work”) under the Tender no. _____ dated _____ should be executed by the OEM AND WHEREAS by a Letter of Award No. _____ dated _____ issued by WAPCOS Limited and accepted by the OEM. WAPCOS Limited has accepted a Bid submitted by the OEM for the execution and completion of such Work AND WHEREAS the OEM has agreed to undertake such Work and furnish a Performance Security _____ (details) pursuant to Tender conditions.

NOW THIS AGREEMENT WITNESSETH as follows;

In this Contract words and expressions shall have the same meanings as are respectively assigned to them in the Conditions of Contract hereinafter referred to.

The following documents shall be deemed to form and be read and construed as part of this Contract, viz;

- a) Tender Document no. _____ dtd. _____
- b) Letter of Award to OEM by WAPCOS
- c) Documents furnished by the OEM during Bidding process
- d) Corrigendum/Amendments, if any
- e) Clarifications / Correspondences, if any
- f) Any other documents as forming part of the contract

1. The aforesaid documents shall be taken as complementary and mutually explanatory of one another.
2. In consideration of the payment to be made by WAPCOS to the OEM as indicated in this Contract, the OEM hereby covenants with WAPCOS to execute and complete the Works in conformity, in all respects, with the provisions of the Contract.
3. WAPCOS hereby covenants to pay the OEM in consideration of the execution and completion of the Works and the remedying of defects therein the Contract Price or such other sum as may become payable under the provisions of the contract at the time and in the manner prescribed by the Contract.

IN WITNESS whereof the parties hereto have caused this Agreement to be executed in accordance with Laws of India on the day, month & year indicated above.

SIGNED, SEALED AND DELIVERED

For and on behalf of the WAPCOS

For and on behalf of the OEM

NAME _____
Designation

NAME _____
Designation

in the presence of witness: _____

in the presence of Witness _____

1 _____

1 _____

2 _____

2 _____

NOTE: OEM shall submit the Original Power of Attorney on Non-Judicial Stamp Paper for this particular Work, in the name of Person who will sign the Contract with WAPCOS after award of Work.

FORMAT FOR LETTER OF AWARD

No.

Date:.....

M/s(Name of successful OEM)

..... (Address of successful OEM)

Subject: Award Letter for “.....(Name of work)”

Reference: Tender No.

Dear Sir,

We are pleased to inform that work of “.....” is awarded to OEM, in cost of Rs. ----- including GST, according to submission of your technical & financial bids against referred tender for the subjected work.

Work	Awarded Cost including GST
.....(Name of work)	Rs.

- The “Date of Commencement of Work” shall be immediately after award of work and accordingly, planning should be started for deploying manpower, resources as per Terms & Conditions of Tender document.
- The tender document wholly accepted by you along with all related correspondences at the time of bidding shall form a part of this letter of award.
- Factory visit of SAI/WAPCOS officials shall be conducted within 05 working days of Letter of Award, hence prepare the sample as per the specifications & BoQ for display of the sample of each furniture items for the approval of SAI/WAPCOS.
- The OEM will submit the GST Invoice for purchase of HDHMR item of particular makes mentioned in tender document along with bills. The date of GST Invoice will be the after the date of Award of Work to the OEM.**
- You are requested to submit the following as per Terms & Conditions of
 - Performance Security @5% of Tendered Value as per the form enclosed in the tender document before signing of the Agreement within 21 (Twenty One) days of the date of acceptance of the letter of award and sign the Contract Agreement.
- Schedule Plan/ Bar chart to complete the work in stipulated time period from the date of award of the work. The OEM will make all efforts to complete the work in given period of time, since work is very urgent in nature as building is ready and campers are to be shifted in the building,
- The terms & conditions of the Work will be governed as mentioned in the tender document.

This letter of award is being issued to you in duplicate. You are requested to return the duplicate copy of the letter of award immediately duly signed and stamped as a token of your unequivocal acceptance and confirmation of the same.

Thanking You,

Yours faithfully,
(Name & Designation
of the Tendering Authority)

SECTION – III

FORMS

[UPLOADED SCANNED COPY MUST BE ON LETTER HEAD OF OEM]

LETTER OF TRANSMITTAL FOR TECHNICAL BID

To,
The Tender Issuing Authority
WAPCOS Limited

Subject: Submission of Bids for “Manufacturing, Supply and Installation of Furniture for 300 Bedded Hostel at SAI, LNCPE Trivandrum”

Having examined the details given in tender document for the above work, I/we hereby submit the relevant information.

- i. I / We acknowledge that the WAPCOS will be relying on the information provided in the Bid and the documents accompanying the Bid & detailed provided in the enclosed “Forms” for selection of the OEM for the aforesaid Work, and we certify that all information provided in the Bid are true and correct; nothing has been omitted which renders such information misleading; and all documents accompanying the Bid are true copies of their respective originals.
- ii. I/we have furnished all information and details necessary for eligibility and have no further pertinent information to supply.
- iii. I/we submit the requisite Solvency Certificate, Completion Certificates, Financial Information’s and authorize WAPCOS Ltd. to approach the Issuing Authority to confirm the correctness thereof. I/we also authorize WAPCOS Ltd. to approach individuals, employers, firms and corporation to verify our competence and general reputation.
- iv. I/ We acknowledge the right of the Authority to reject our Bid without assigning any reason or otherwise and hereby waive, to the fullest extent permitted by applicable law, our right to challenge the same on any account whatsoever.
- v. I/we submit the following certificates in support of our suitability, technical knowledge and capability for having successfully completed the following eligible similar works:

Name of work	Certificate from

Date:

**(Signature, Name, Designation
of the Authorized signatory with Seal)**

Place:

[UPLOADED SCANNED COPY MUST BE ON LETTER HEAD OF OEM]

LETTER OF TRANSMITTAL FOR FINANCIAL BID

Date:

To
The Tender Issuing Authority
WAPCOS Limited

Sub: Financial Bid for “Manufacturing, Supply and Installation of Furniture for 300 Bedded Hostel at SAI, LNCPE Trivandrum”

Dear Sir,

With reference to this Tender Document, I/we, having examined the Bidding Documents and understood their contents, hereby submit my/our Bid for the aforesaid Work. The Bid is unconditional and unqualified.

1. The Cost has been quoted by me/us for bid after taking into consideration all the terms and conditions stated in the Tender Document, our own estimates of costs and after a careful assessment of the site and all own the conditions that may affect the work cost and implementation of the work.
2. I / We shall keep this offer valid as period specified in the NIT.
3. I / We hereby submit our FINANCIAL BID and Cost as filled in GeM portal for undertaking the aforesaid work in accordance with the quality parameters of furniture items as specified in Bidding Documents.
4. I / We hereby submit that the cost quoted for each item of furniture are as per the standard prices of OEM. The furniture items considered for the supply are best in quality and its quoted rates are equivalent to the estimated rates given in the tender document.

Yours faithfully,

Date:

(Signature, name and designation
of the Authorized signatory)

Place:

Name and seal of OEM

[UPLOADED SCANNED COPY MUST BE ON LETTER HEAD OF OEM]**DECLARATION BY THE OEM**

This is to certify that We, M/s, in submission of this offer confirm that:-

We have inspected the site of work and have made myself/ourselves fully acquainted with local conditions in and around the site of work. We have carefully gone through each & every section of the tender document for the work “**Manufacturing, Supply and Installation of Furniture for 300 Bedded Hostel at SAI, LNCPE Trivandrum**”.

1. Our tender is offered taking due consideration of all factors mentioned in tender documents.
2. We promise to abide by all the stipulations of the Contract documents and carry out and complete the work to the satisfaction of the Employer/ Principal Employer.
3. We also agree to procure Plants and Machineries at our cost required for the work. We also submit that we have Organizational Structure comprising adequate Technical Personnel in the line of requirement. We also agree to accomplish the job entrusted to us in the stipulated time laid out in document except situations not under our control.
4. We have not made any misleading or false representation in the forms, statement and attachments in proof of the qualification requirements;
5. We do not have records of poor performance such as abandoning the work, not properly completing the Contract, inordinate delays in completion or financial failures etc.
6. We have submitted all the supporting documents and furnished the relevant details as per prescribed format.
7. We are financially sound and have not applied or be under corporate debt restructuring.
8. List of Similar Works satisfying Qualification Criterion as indicated hereinafter, does not include any work which has been carried out by us through a Subcontractor on a back-to-back basis.
9. The Cost has been quoted by me/us for bid after taking into consideration all the terms and conditions stated in the Tender Document, our own estimates of costs and after a careful assessment of the site and all own the conditions that may affect the project cost and implementation of the project.
10. I / We shall keep this offer valid as period specified in the NIT.
11. I / We hereby submit our FINANCIAL BID and Offer Cost for undertaking the aforesaid Project in accordance with the Bidding Documents and the Agreement.
12. In the event of my/ our being declared as the Selected OEM, I/we agree to enter into a Agreement in accordance with the format of Contract Agreement. We agree not to seek any changes in the aforesaid format of Contract Agreement and agree to abide by the same.

Certificate:

It is certified that the information given in the enclosed bid are correct. It is also certified that I/we shall be liable to be debarred, disqualified / cancellation of enlistment in case any information furnished by me/us found to be incorrect.

Date:

**(Signature, Name, Designation
of the Authorized signatory with Seal)**

Place:

**[UPLOADED SCANNED COPY MUST BE ON LETTER HEAD OF STATUTORY
AUDITOR/OEM's CHARTED ACCOUNTANT]**

FORM-A: FINANCIAL INFORMATION

Years	Gross Annual turnover	Profit/Loss (After Tax)	Net worth
2018-2019			
2019-2020			
2020-2021			
2021-2022			
2022-2023			

Above Details are being furnished as per the figures in balance sheet for the last five years in respect of M/s(Name & address of OEM), as submitted by OEM to the Income Tax Department.

Date:

**(Signature of Statutory Auditor/ OEM's
Chartered Accountant with Seal)**

Place:

UDIN No. :

[TO BE SUBMITTED ON ORIGINAL LETTER HEAD OF ISSUING BANK]

FORM- B: SOLVENCY CERTIFICATE

To
WAPCOS Limited,
76-C, Institutional Area,
Sector-18, Gurugram, Haryana

.....M/s.....(name of OEM &
address).....
..... (as per standard format of Solvency Certificate by issuing
Bank).....
.....
.....
.....

(Signature for The Bank)

NOTE:

1. The Solvency Certificate should be on letter head of the Bank addressed to WAPCOS Limited, 76-C, Institutional Area, Sector-18, Gurugram, Haryana. The language of this Form may be changed as per the standard format of Bank, without affecting the objective.

[UPLOADED SCANNED COPY MUST BE ON LETTER HEAD OF OEM]

FORM-C: CORRESPONDENCE DETAILS OF ISSUING AUTHORITY

Bank Guarantee/ Solvency / Completion Certificate

Name of Work: “Manufacturing, Supply and Installation of Furniture for 300 Bedded Hostel at SAI, LNCPE Trivandrum”

1. Solvency Certificate

Present address of the Issuing Branch	Official Email Id	Landline no	Other Contact no.

2. Completion Certificate

Present address of the Issuing Authority	Official Email Id	Landline no	Other Contact no.

This is to certify that above information is correct and is gathered from the Issuing Authorities by us for the verification of concerned documents. We understand that if the documents is not verified by the issuing authority within 5 working days, then our bid may be rejected by WAPCOS and only we will be the responsible for the rejection.

Date:

**(Signature, Name, Designation
of the Authorized signatory with Seal)**

Place:

[UPLOADED SCANNED COPY MUST BE ON LETTER HEAD OF OEM]

FORM- D: STRUCTURE & ORGANISATION

Name of Work: “Manufacturing, Supply and Installation of Furniture for 300 Bedded Hostel at SAI, LNCPE Trivandrum”

S.No.	Particulars	Details
1.	Name & Registered Address of Corporate Office of OEM	
2.	Official Website of OEM	www.....
3.	Address and Email on which Correspondence will be made during Tendering & after Award of Work	
4.	Telephone no./Telex no./Fax no.	
5.	Legal status of the OEM (attach copies of original document defining the legal status) (a) A Proprietary Firm (b) A Partnership Firm (c) A Limited Company or Corporation (d) A Company registered under company's Act 1956/2013	
6.	Names and Titles of Directors with designation as per Legal Status of OEM	
7.	Designation of Senior Level Officers authorized to act for this work	
8.	Any other information considered necessary but not included above.	

Date:

**(Signature, Name, Designation
of the Authorized signatory with Seal)**

Place:

[UPLOADED SCANNED COPY MUST BE ON LETTER HEAD OF OEM]

FORM-E: NO-CONVICTION CERTIFICATE

Name of Work: “Manufacturing, Supply and Installation of Furniture for 300 Bedded Hostel at SAI, LNCPE Trivandrum”

This is to certify that _____ (Name of the organization), having registered office at _____ (Address of the registered office) has never been convicted by any Central / State Government Department or Court of law anywhere in the country.

This is also to certify that we are not involved in any form of Corrupt and Fraudulent Practices in past and will never be involved in future.

Date:

**(Signature, Name, Designation
of the Authorized signatory with Seal)**

Place:

[UPLOADED SCANNED COPY MUST BE ON LETTER HEAD OF OEM]

FORM-F: NO DEVIATION CERTIFICATE

Name of Work: “Manufacturing, Supply and Installation of Furniture for 300 Bedded Hostel at SAI, LNCPE Trivandrum”

This is to confirm that as per Tender conditions we have visited the building and its location before submission of our Offer and noted the job content upto installation of furniture with best fit in the hostel room, studio rooms, dining area and other areas where furniture is to be installed. We also confirm that we have not changed/modified the above tender document and in case of observance of the same at any stage it shall be treated as null and void.

We hereby also confirm that we have not taken any deviation from Tender Clause together with other reference as enumerated in the above referred Notice Inviting Tender and we hereby convey our unconditional acceptance to all terms & conditions as stipulated in the Tender Document.

In the event of observance of any deviation in any part of our offer at a later date whether implicit or explicit, the deviations shall stand null and void.

Date:

**(Signature, Name, Designation
of the Authorized signatory with Seal)**

Place:

[UPLOADED SCANNED COPY MUST BE ON LETTER HEAD OF OEM]

FORM-G: UNDERTAKING REGARDING BLACKLISTING / NON DEBARMENT

Name of Work: “Manufacturing, Supply and Installation of Furniture for 300 Bedded Hostel at SAI, LNCPE Trivandrum”

This is to certify that we have taken the cognizance of Blacklisting Policy of WAPCOS Ltd. Further, we hereby Confirm and declare that we, M/s_____ , is not blacklisted/De-registered/debarred by any Government Department/Public Sector Undertaking /Private Sector/ or any other agency for which we have Executed / Undertaken the works/ Services during the last 5 Years.

Date:

**(Signature, Name, Designation
of the Authorized signatory with Seal)**

Place:

[UPLOADED SCANNED COPY MUST BE ON LETTER HEAD OF OEM]

FORM-H: UNDERTAKING FOR RULE 144 (XI) IN THE GENERAL FINANCIAL RULES-2017

Name of Work: “Manufacturing, Supply and Installation of Furniture for 300 Bedded Hostel at SAI, LNCPE Trivandrum”

I / we(Name of the OEM)
well aware about the Restrictions under RULE 144 (XI) In General Financial Rules (GFR), 2017 on procurement from country which shares a land border with India.. I/ we hereby certify that we are eligible to participate in the tender as per Rule 144 (xi) In The General Financial Rules (GFR), 2017

Date:

**(Signature, Name, Designation
of the Authorized signatory with Seal)**

Place:

[UPLOADED SCANNED COPY MUST BE ON LETTER HEAD OF OEM]

FORM-I: UNDERTAKING REGARDING PERCENTAGE OF LOCAL CONTENT

Name of Work: “Manufacturing, Supply and Installation of Furniture for 300 Bedded Hostel at SAI, LNCPE Trivandrum”

We..... (Name of OEM)
hereby confirm that we will follow the Make in India Policy and its Guidelines at the time of execution of subjected work. We have understood the provisions of Public Procurement (Preference to make in India) Local content Policy and will achieve the minimum local content target of 50%.

Date:

**(Signature, Name, Designation
of the Authorized signatory with Seal)**

Place:

[UPLOADED SCANNED COPY MUST BE ON LETTER HEAD OF OEM]

FORM-J: PERFORMANCE OF WORKS AWARDED BY WAPCOS (COMPLETED & ONGOING)

Name of Tender: Manufacturing, Supply and Installation of Furniture for 300 Bedded Hostel at SAI, LNCPE Trivandrum.

This is to certify that our OEM is engaged in following ongoing works of WAPCOS and was engaged in following completed works (completed after 30.06.2019) as detailed below

SN	Name of Project	Location & state	Date of Award	Award Value

Date:

(Signature, name and designation
of the Authorized signatory)

Place:

Name and seal of OEM

NOTE:

1. If OEM is not engaged by WAPCOS ever, then OEM will submit above information as NIL and their bid will be considered during evaluation.
2. If OEM is engaged in various works of WAPCOS, then it is mandatory to disclose the same in above format. In this condition, OEM will submit format FORM J(a) regarding performance of the OEM for completed and on-going works duly certified from the each concerned WAPCOS Official for each works. The same will be verified from the concerned WAPCOS Official. If the performance of the OEM is not satisfactory in any parameter of "Performance" mentioned in Form- J(a), then his bid will not be considered for evaluation.
3. It is mandatory for the OEM to disclose all the completed and ongoing projects in WAPCOS and to submit the Form J and J(a). If the OEM hide any project which is under progress or completed in WAPCOS, then his bid will not be considered for evaluation.

[To be submitted by OEMs on Letter Head of WAPCOS]

FORM-J (a): FORMAT FOR PERFORMANCE OF WORKS AWARDED BY WAPCOS
DULY CERTIFIED BY WAPCOS OFFICIAL

Performance Certificate

Sno	Details	Particulars	
1.	Name of Work / Project & Location		
2.	Awarded Cost	Rs.	
3.	Date of Start		
4.	Stipulated Date of Completion		
5.	Actual Date of Completion		
7.	Physical Progress on the date of publication of Tender		
8.	Performance Parameters:		
	a) Complain regarding quality of work from client/ WAPCOS	No (satisfactory)	Yes (not satisfactory)
	b) Progress of Work	Satisfactory	Not satisfactory
	c) Timely Completion	Yes (satisfactory)	No (not satisfactory)

Note: This certificate is being issued by WAPCOS on the request of M/s..... (Name of OEM) for participation in work "Manufacturing, Supply and Installation of Furniture for 300 Bedded Hostel at SAI, LNCPE Trivandrum". This certificate is not valid for any Legal/ Arbitration proceedings & financial claims for the work mentioned above at SNo.-1

**(Signature, Name and Designation
of the Nodal Officer of WAPCOS)**

[UPLOADED SCANNED COPY MUST BE ON LETTER HEAD OF OEM]

Form-K: Undertaking for owning the Plants & Machineries

Name of Work: “Manufacturing, Supply and Installation of Furniture for 300 Bedded Hostel at SAI, LNCPE Trivandrum”

I / we(Name of the OEM)
certify that following Machinery are available in our manufacturing unit and own the ownership for the same.

- CNC Machine for designer cutting
- Hydraulic CNC tube Bending Machine
- MIG Welding machine
- Laser Cutting Machine
- NC bending Machine
- Powder coating Booth and furnace

I/ We acknowledge the right of the Authority to reject our Bid, if above Plants & Machineries are not available in our manufacturing unit/ Plant.

Date:

**(Signature, Name, Designation
of the Authorized signatory with Seal)**

Place:

SECTION – IV

TERMS OF REFERENCE

SECTION – IV TERMS OF REFERENCE

1.0 DEFINITIONS

In the contract, the following expressions shall, unless the context otherwise requires, have the meanings, hereby respectively assigned to them:-

- The “**Contract**” means the documents forming the tender and acceptance thereof and the formal Agreement executed between the WAPCOS and the OEM, together with the documents referred to therein including these conditions, the specifications, designs, drawings and instructions issued from time to time by the Engineer-In-Charge and all these documents taken together, shall be deemed to form one contract and shall be complementary to one another.
- “**Employer**” shall mean WAPCOS Limited/ WAPCOS, A Government of India undertaking- Ministry of Jal Shakti, for execution of the Work as mentioned in NIT, having their Registered office at 5th floor, Kailash building, 26-Kasturba Gandhi Marg, New Delhi-110001, India & include Engineer-in-charge, Project Manager, their successors & permitted assigns as well as their authorized officer / representatives. WAPCOS Limited is a company registered under the Indian Company Act 1956, with its registered office at New Delhi or its Administrative officers or its Engineer or other employees authorized to deal with any matter with which these persons are concerned and authorized on its behalf.
- “**Principal Employer/Owner**” **Sports Authority of India, Ministry of youth Affairs & Sports** who has appointed WAPCOS Ltd. as Work Management Consultant for the work mentioned in NIT.
- “**OEM**” shall mean the individual, firm or company, whether incorporated or not, undertaking the works and shall include the legal personal representative of such individual or the persons composing such firm or company, or the successors of such firm or company and the permitted assignees of such individual, firm or company who are participating in Bidding process and will Execute Works and have their own Manufacturing Unit for manufacturing of furniture.
- “**Work**” means as mentioned in NIT.
- “**Site and location**” means the land/or other places on, into or through where furniture is to be supplied and installed under the contract as mentioned in NIT.
- “**Engineer-in-Charge**” means the Officer appointed by WAPCOS who shall direct, supervise and sign the Contract Agreement on behalf of WAPCOS, for the purpose of Contract or his duly authorized representative.
- “**Work Manager, WAPCOS**” shall mean the officer appointed by WAPCOS to supervise the works at site on behalf of WAPCOS and Authorized by the Engineer-in charge.
- “**Tendered Amount**” means the value as quoted by the OEM during bidding process including GST.
- “**Tendered Value**” means the value of work as stipulated in the letter of award including GST.
- “**Contract Price**” means the value of work executed under the Contract including tendered value, cost of extra items, cost of substituted items, cost of deviated items, works executed under the Contract including GST.
- “**Date of Commencement of Work**”: The date of commencement of work shall be the date of start as specified in Letter of Award or the first date of handing over of the site, whichever is later, in accordance with the phasing if any, as indicated in the tender document.
- **GST** means Goods & Service tax- Central, State and Inter State

2.0 PERFORMANCE SECURITY (OR PERFORMANCE BANK GUARANTEE)

- i. The OEM shall submit an irrevocable **Performance Security of 5% (Five percent) of the “Tendered Value” as per Annexure- II** in addition to other deposits mentioned elsewhere in the contract for his proper performance of the contract agreement, (not withstanding and/or without prejudice to any other provisions in the contract) within period specified in Special Conditions of Contract from the date of issue of letter of acceptance. This period can be further extended by the Engineer-in-Charge up to a maximum period as specified in Special Conditions of Contract on written request of the OEM stating the reason for delays in procuring the Performance Security, to the satisfaction of the Engineer-in-Charge. This Security shall be in the form of Cash (in case Security amount is less than Rs. 10,000/-) or Banker’s Cheque of any scheduled bank/Demand Draft of any scheduled bank/Pay Order of any scheduled bank (in case Security amount is less than Rs. 1,00,000/-) or Fixed Deposit Receipts or Guarantee Bonds of any Scheduled Bank or the State Bank of India in accordance with the form annexed hereto. In case a fixed deposit receipt of any Bank is furnished by the OEM to the WAPCOS as part of the performance Security and the Bank is unable to make payment against the said fixed deposit receipt, the loss caused thereby shall fall on the OEM and the OEM shall forthwith on demand furnish additional security to the WAPCOS to make good the deficit.
- ii. The Performance Security shall be initially valid up to period of 90 days beyond the date of completion agreed plus 1 year claim period beyond that. In case the time for completion of work gets enlarged, the OEM shall get the validity of Performance Security extended to cover such enlarged time. The performance Security shall be refunded to the OEM without interest, after 1 years of successful completion of installation of furniture work or 1 year after Completion of the project Construction of 300 Bedded Hostel at SAI, LNCPE Trivandrum as recorded by SAI, whichever is later.
- iii. The Engineer-in-Charge shall make a claim under the performance Security except for amounts to which the WAPCOS is entitled under the contract (not withstanding and/or without prejudice to any other provisions in the contract agreement) in the event of:
- iv. Failure by the OEM to extend the validity of the Performance Security as described herein above, in which event the Engineer-in-Charge may claim the full amount of the Performance Security. Failure by the OEM to pay WAPCOS any amount due, either as agreed by the OEM or determined under any of the Clauses/Conditions of the agreement, within 30 days of the service of notice to this effect by Engineer-in-Charge.
- v. In the event of the contract being determined or rescinded under provision of any of the Clause/Condition of the agreement, the performance Security shall stand forfeited in full and shall be absolutely at the disposal of the WAPCOS.

3.0 SECURITY DEPOSIT / RETENTION MONEY

The OEM whose tender(s) may be accepted shall permit WAPCOS at the time of making any payment to OEM for work done under the contract to deduct a sum at the rate of 5% from each running and final bill excluding GST. No interest shall be paid on the amount so deducted.

The Security Deposit as deducted above shall be released after 2 years of successful completion of installation of furniture as Certified by the Engineer-in-Charge.

4.0 COMPENSATION FOR DELAY i.e. LIQUIDITY DAMAGE

If the OEM fails to maintain the required progress or to complete the work and clear the site on or before the contract or extended date of completion, he shall, without prejudice to any other right or remedy available under purview of the Contract on account of such breach, pay compensation for delay i.e. Liquidity Damage, a sum not less than 2.5% (Two Point Five percent) of the Tendered Value as aforesaid for each week and limited to 10% of the Contract Price.

In case Liquidity Damage imposed by Principal Employer to the work at any point of time, then full amount of Liquidity Damage (10% of the Contract Price) will be recovered from the up-coming interim bills/ final bill. If the amount of up-coming interim bills/ final bill is less than the amount of Liquidity Damage, then balance amount of Liquidity Damage will be recovered from the Performance Security, Security Deposit and any other financial deposit of OEM with Employer.

5.0 COMPLETION PERIOD

The completion period will be 45 days from the date of award of the work. the OEM will make all efforts to complete the work in given period of time. The record date of completion shall be successful completion of installation of furniture work or Completion of the project Construction of 300 Bedded Hostel at SAI, LNCPE Trivandrum as recorded by SAI, whichever is later.

6.0 TEST CERTIFICATES

OEM shall provide Manufacturer's Material Test Certificate for the materials / makes which will be used for manufacturing of furniture along with bills or as and when required by Engineer-in charge during the execution of work.

7.0 WARRANTY PERIOD

- The OEM shall certify that no sub-standard materials have been used in the work and shall provide **Warranty Certificate for a period of at least 5 years after successful installation of furniture** in hostel building at consignee location and acceptance of the furniture by client with their full satisfaction. The OEM shall submit the Warranty /Guarantee Certificate on non-judicial stamp per as per **Annexure-III**
- If any major defect appears in the furniture, then it will be replaced during the warrantee / guarantee by the OEM free of cost & nothing shall be paid extra on any account.
- Any defects or other faults which may appear within warrantee / guarantee period from the date of successful installation of furniture shall be rectified promptly on notification in writing by the WAPCOS in this regard and repairs or replacement will be carried out with the materials identical to the original.

8.0 Payment Terms

- The payment shall be made after successful installation of particular furniture item of work mentioned in Bill of Quantities at site and after submission of running invoices duly signed and verified by the Project Manager, WAPCOS and approved by the Engineer-in Charge.
- **The OEM will submit Tax Invoice for the completed works of furniture as per tender condition. The Tax Invoice will be billed to WAPCOS limited, 3rd floor, Chacko Towers, Jew Street, Pullepady, Ernakulam, Kochi , Kerala with WAPCOS GSTIN/ UIN no. 32AAACW0764A2ZX.**
- The OEM will submit the GST Invoice for purchase of HDHMR item of particular makes mentioned in tender document along with each bill. The date of GST Invoice will be the after the date of Award of Work to the OEM.
- The payment shall be made after successful installation of particular furniture item of work mentioned in Bill of Quantities at site and after submission of running invoices duly signed and verified by the Engineer In-charge of WAPCOS.
- The payment will be made according to the actual installed quantities by the OEM in respect of Bill of Quantities.

- The OEM acknowledges that under the present Tender and Work Order/ Contract Agreement (if work is awarded to OEM), WAPCOS is only working as intermediary between SAI being Principal Employer. Thus the OEM unconditionally acknowledges that the payments under the present Tender and Work Order/ Contract Agreement (if work is awarded to OEM) shall be made proportionately by WAPCOS only on back to back basis i.e., after 45 days subject to receipt of payment from SAI being Principal Employer. The OEM also unconditionally agree that in the event the, payment or part thereof, under the present Tender and Work Order/ Contract Agreement (if work is awarded to OEM) is not received from SAI, then WAPCOS &/or any of its Employee/ Officer shall not be responsible to pay any amount to OEM. The said condition shall supersede any and all other conditions of Tender and Work Order/ Contract Agreement between the parties (if work is awarded to OEM).
- All payments shall be released by way of e-transfer through RTGS in India directly at their Bank account by WAPCOS.

9.0 Insurance

The goods supplied under the fully insured in Indian Rupees against lost/theft/ damage incidental to manufacture or acquisition/ transportation, storage/ delivery, the insurance shall be obtained by the OEM in an amount equal to 100% of the value of goods from warehouse to Project site on all risk basis including war risks and strikes.

10.0 Safety & Security Measures

The OEM will take all the safety, security measures and insurance etc. of the workers/labourers involved in the works as per the standard guidelines of the CPWD Works Manual 2022.

11.0 Arbitration

Any dispute, controversy or claims arising out of or relating to this Contract Agreement (Agreement that will be signed between WAPCOS and OEM, if work is awarded to OEM), or the breach termination or invalidity thereof shall be settled through following mechanism:

- Firstly, the aggrieved party shall write a letter to the other party detailing its grievances and calling upon the other party to amicably resolve the dispute by convening a joint meeting. Accordingly, the parties as per their convenience shall jointly convene the said meeting(s), wherein minutes of the said meeting(s) shall be prepared and countersigned by all the parties it is mandatory to prepare minutes of meeting(s) and to be countersigned by all the parties, irrespective of the outcome of the said meeting(s).
- In the event the parties are unable to reach on any settlement in the said meeting(s), then the aggrieved party shall mandatory resort to pre-litigation mediation mechanism with Delhi High Court Mediation Cell, New Delhi.
- It is only upon failure of the pre-litigation mediation mechanism with Delhi High Court Mediation Cell then the aggrieved party shall resort to resolution of disputes through arbitration of a Sole Arbitrator. The appointing authority of Sole Arbitrator is CMD, WAPCOS Limited, to which neither of the parties have any objection nor they shall ever object.
- Subject to the parties agreeing otherwise, the Arbitration proceedings shall be conducted in accordance with the provisions of the Indian Arbitration and Conciliation Act, 1996 (amended as on date).
- It is also acknowledged and accepted that WAPCOS is only working as Intermediary between the OEM and SAI being Principal Employer, thus in the event, any dispute arises under the Contract Agreement (Agreement that will be signed, if work is awarded to OEM) and referred to Arbitration for adjudication, then subject to corresponding clause in the Memorandum of Agreement between SAI and WAPCOS, SAI shall also be made party to the said Arbitration proceedings. Also, the award including costs if any passed against WAPCOS and costs incurred in the proceedings shall be the sole responsibility of SAI. The said clause if found

inapplicable, even then the other terms of the Arbitration Clause shall survive and shall be acted upon.

- f) The place/seat of arbitration shall be Delhi and any award whether interim or final, shall be made, and shall be deemed for all purposes between the parties to be made, in Delhi. The arbitral procedure shall be conducted in English language and any award or awards shall be rendered in English. The procedural law of the arbitration shall be Indian Law. The award of the arbitrator shall be final and conclusive and binding upon the Parties.
- g) The Contract and any dispute or claim arising out of or in connection with it or its subject matter or formation (including non-contractual disputes or claims) shall be governed by and construed in accordance with the laws of India and the Parties submit to sole & exclusive jurisdiction of courts at Delhi."

12.0 Governing Laws and Jurisdiction

The tender document shall be governed by the Indian Laws and Rules as amended from time to time. The Courts of Delhi alone shall have exclusive Jurisdiction in all matters arising under this contract.

13.0 Additional Conditions

- The OEM shall be responsible for consequential effects arising out during the inspection done by the Chief Technical Examiner Cell, Central Vigilance Commission or Project Management Group (PMG) constituted by the Sports Authority of India (SAI) or by the Building Works Committee or third party authorized by WAPCOS or any statutory committee or by any duly authorized representative of WAPCOS, during the progress of works up to the defect liability period, and will take appropriate action for rectification of defective work and modifications as suggested by the above teams/ group/ individual. Rectification of defective works or replacement of sub-standard materials or articles or modifications, as pointed out by the Chief Technical Cell, Central Vigilance Commission, Project Management Group (PMG) constituted by the Sports Authority of India (SAI), Head of concerned Regional Center of SAI, Building Works Committee or authorized representative of WAPCOS or third party authorized by WAPCOS/ SAI or any statutory committee, will be carried out or replaced/ modified by the OEM at his own risk and cost. WAPCOS will not pay any extra amount for such rectification or replacement
- The work shall be executed as per Indian Standard Specification, Code(s) of practice of Bureau of Indian Standards (formerly ISI) or any such other specifications as may be decided mutually by the WAPCOS and SAI.
- If any type of the miss-happening during the execution of work (i.e. Injury/Mobilization/Loss/Losses in Transportation/ losses in Installation /Theft etc.) & the responsibility of skilled & un-skilled labor or any legal matter involved in this matter in the concerned jurisdiction will be borne by OEM.
- The OEM shall dispose of all the dismantled materials, debris, garbage, waste outside of the campus of the works at his own cost and provide clear and clean site at the time of handing over the works
- OEM should hand over the warranty of the branded/ specialized items of furniture.
- In case of any inconsistency between clauses, the clause favorable/ beneficiary to the Work will prevail which will be decided by the owner and WAPCOS.

14.0 Conditions of Contract

The Conditions other than above, if arises during execution of work will be governed by the General Conditions of Contract as per CPWD Works Manual 2022.

Annexure – II

(To be submitted on non-judicial stamp paper of Rs. 100)

FORMAT FOR PERFORMANCE BANK GUARANTEE

To,
The WAPCOS Limited,
76-C, Sector 18, Institutional Area
Gurugram, Haryana-122015.

In consideration of _____ (Employer's name) (hereinafter referred to as "the Employer") which expression shall, unless repugnant to the context or meaning thereof include its successors, administrators and assigns) having awarded to _____ (OEM's name & address) (hereinafter referred to as "the OEM" which expression shall unless repugnant to the context or meaning thereof, include its successors, administrators, executors and assigns) a contract, by issue of Employer's Notification of Award No. _____ dt. _____ and the same having been unequivocally accepted by the OEM, resulting into a contract valued at Rs. _____ (Rupees _____ only) for _____ (name of work) (hereinafter called "the contract") and the OEM having agreed to provide a Contract Performance Security for the faithful performance of the entire contract equivalent to Rs. _____ (Rupees _____ only) (5% of the said value of the Contract to the Employer).

We, _____ (name & address of bank) (hereinafter referred to as "the Bank" which expression shall, unless repugnant to the context or meaning thereof, include its successors, administrators, executors and assigns) do hereby guarantee and undertake to pay the Employer, on demand any or, all monies payable by the OEM to the extent of Rs. _____ (Rupees _____ only) as aforesaid at any time upto _____ without any demur, reservation, contest, recourse or protest and/or without any reference to the OEM or court. Any such demand made by the Employer on the bank shall be conclusive and binding notwithstanding any difference between the Employer and the OEM or any dispute pending before any Court, Tribunal, Arbitrator or any other authority. The Bank undertakes not to revoke this guarantee during its currency without previous consent of the Employer and further agrees that the guarantee herein contained shall continue to be enforceable till the Employer discharges this guarantee.

We the said Bank further agree that the guarantee herein contained shall remain in full force and effect during the period that would be taken for the performance of the said Contract and that it shall continue to be enforceable till all the dues of the Employer under or by virtue of the said contract have been fully paid and its claims satisfied or discharged or till the Employer certifies that the terms and conditions of the said Contract have been fully and properly carried out by the said OEM and accordingly discharges the guarantee.

The Employer shall have the fullest liberty without affecting in any way the liability of the Bank under this guarantee, from, time to time to extend the time for performance of the Contract by the OEM. The Employer shall have the fullest liberty without affecting this guarantee, to postpone from time to time the exercise of any powers vested in them or of any right which they might have against the OEM and to exercise the same at any time in any manner and either to enforce or to forbear to enforce any covenants, contained or implied, in the Contract between the Employer and the OEM or any other course or remedy or security available to the Employer. The bank shall not be released of its obligations under these presents by any exercise by the Employer of its liberty with reference to the matters aforesaid or any of them or by reason of any other act or forbearance or other acts of omission or commission on the part of the Employer or any other indulgence shown by the Employer or by any other matter or thing whatsoever which under law would but for this provision, have the effect of relieving the Bank. The guarantee shall

not be affected by a change in the constitution of the bank or of the employer.

The bank also agrees that the Employer at its option shall be entitled to enforce this Guarantee against the Bank as a principal debtor, in the first instance, without proceeding against the OEM and notwithstanding any security or other guarantee that the Employer may have in relation to the OEM's liabilities.

We The Said Bank do hereby declare that we have absolute and unconditional power to issue this guarantee in your favour under the Memorandum and Articles of Association or such other constitutional documents of the Bank and the undersigned have full power to execute this guarantee under the Power of Attorney / Post Approval Authorization dated _____ of the bank granted to him / us by the Bank. We the said bank do hereby declare and undertake that your claim under the guarantee shall not be affected by any deficiency or other defect in the powers of the bank or its officials and the guarantee shall be deemed to have been issued as if the bank and its officials have all the powers and authorization to give this guarantee on behalf of the bank.

We the said bank do hereby certify the genuineness and appropriateness of the Stamp paper and stamp value used for issuing the guarantee. We the said bank do hereby declare and undertake that your claim under the guarantee shall not be affected by any deficiency or other defect in the stamp paper or its stamp value.

We the said bank do hereby declare that our payments hereunder shall be made to you , free and clear of and without and deduction, reduction on account of any reasons including any and all present and future taxes, levies, charges of withholding whatsoever imposed or collected with respect thereto.

Notwithstanding anything contained hereinabove our liability under this guarantee is restricted to Rs. _____(Rupees _____ only) and it shall remain in force upto and including _____ and shall be extended from time to time for such period as may be desired by M/s WAPCOS Limited to whom this bank guarantee has been given.

Notwithstanding anything contained herein

- i) Our liability under this guarantee shall not exceed Rs. _____ (Rupees _____ only);
- ii) This bank guarantee shall be valid upto _____; and
- iii) our liability to make payment shall arise and we are liable to pay the guaranteed amount or any part thereof under this guarantee, only and only if you serve upon us a written claim or demand in terms of the guarantee on or before _____ (**indicate a date twelve month after validity of Guarantee**)

Dated this _____ day of _____ at New Delhi.

Authorized Signatory of Bank

Signature

Signature

Name.....

Name.....

Signature Code/ S.S no.

**Signature Code/ S.S no.
.....**

Annexure – III

(On Rs. 100 non- Judicial Stamp Paper duly attested by Notary / Magistrate)
FORMAT FOR WARRANTY / GUARANTEE CERTIFICATE

This Agreement made on this ____ day of _____ 20__ between_____ (Name of OEM & address) _____ (hereinafter called the OEM/ GUARANTOR of the one part) and the _____(hereinafter called Employer of the other part) for Warranty Certificate for the work “Manufacturing , Supply & Installation furniture fir 300 bedded hostel at SAI, LNCPE Trivandrum”.

WHEREAS This Agreement is Supplementary, to a Contract (hereinafter called the Original Contract) Contract no. _____ dated _____ and made between the _____ (Name of Contractor) and WAPCOS LIMITED, 5th floor, Kailash Building, 26, K. G. Marg, New Delhi, whereby the contractor, inter alia, undertook to render the Warranty/ Guarantee of 5 years for the supplied furniture under the Original Contract.

THE GUARANTOR hereby provide the Warranty/ Guarantee of 5 years for the supplied furniture in all respect including damage, rectification and replacements for wooden, hardware, steel and other materials used for the manufacturing of the supplied furniture. The period of 05 (five) years to be reckoned from the date of successful installation of furniture in hostel building at consignee location and acceptance of the furniture by client with their full satisfaction

During the period of Warranty/ Guarantee the Guarantor shall remove all defects and replacement (if required) to the satisfaction of the Employer at his cost and shall commence the work for such rectification within seven days from the date of issue of notice from the Employer calling upon him to rectify the defects, failing which the work shall be got done by the Employer through some other Agency at the Guarantor’s cost and risk. As to the amount of loss and / or cost incurred by the Employer on the decision of the Employer will be final and binding to the Guarantor and will be paid by Guarantor to the Employer.

IN WITHNES WHEREOF those presents have been executed by the GUARANTOR(Name and Designation who sign the Contract) on behalf of(Name of OEM) and Employer on the day, month and year first above written.

SIGNED, SEALED AND DELIVERED

For and on behalf of the OEM	For and on behalf of the Employer
-------------------------------------	--

NAME _____
 Designation _____

NAME _____
 Designation _____

in the presence of witness:

in the presence of Witness

1 _____

1 _____

2 _____

2 _____

SECTION – V

SCOPE OF WORK

SECTION-V

SCOPE OF WORK

1. General

WAPCOS Limited is a “MINI RATNA-I” Public Sector Enterprise under the aegis of the Union Ministry of Jal Shakti, Government of India. WAPCOS is Project Management Consultant for executing the work of Construction of 300 Bedded Hostel at SAI, LNCPE Trivandrum. The quality furniture from OEM of furniture across India are required for hostel room, studio room, dining area, reception area, etc. to facilitates the Sports campers.

The hostel building (where proposed furniture is to be installed) comprises of 3 Floors. The furniture items of hostel & Studio room shall match with the colour of wall & wardrobe of Hostel Rooms, Studio Rooms and as decided by SAI LNCPE Trivandrum. Total Hostel Room is 104 nos. in newly constructed hostel building The 3 nos. Single bed; 3 nos. Hostel room Study Table and 3 nos. Hostel Room chairs shall be installed in the one Hostel Room which is triple Occupancy accommodation for Sports Campers.

Total studio unit is 18 nos. in newly constructed hostel building. The 1 no. King Size bed; 1 no. Studio Room Study Table; 1 no. Studio Room chair; 1 no. Bed Side Table; 1 no. Centre Table; 1 no. 2 seater Sofa Set for each 18 nos. of Studio Unit shall be installed for accommodation of Coaches and VIPs. The Dining Table & Dining Chairs shall be installed in Dining Hall. The Reception Table; 3 seater sofa; single seater sofa, 2 no. Centre Table and 1 no. Reception Chair will be installed in reception area.

2. Scope of Work

Tender is inviting from the reputed “OEM” for Manufacturing, Supply and Installation of following Furniture.

The proposed furniture should be Factory made as per the BoQ, drawings and images. The specifications of the furniture will govern in combination of detailing provided in BoQ, drawings and images together. The selected OEM will **prepare and display one sample of each furniture item to the members of WAPCOS/SAI at OEM’s Manufacturing Site** before bulk manufacturing of the required furniture, for approval.

After the approval of sample furniture items, OEM may go for bulk manufacturing. The OEM may supply the Dinning Chairs & Hostel Room chairs after procurement from reputed brands like Supreme/Nilkamal/ Cello/AADB Plastic/equivalent as per specification and images, if it is not being manufactured by OEM. The OEM will procure Dinning Chairs & Room chairs after approval of WAPCOS/SAI. WAPCOS/SAI may reject the samples of furniture, if sample is not upto the mark in term of material, quality, appearance & finishing. In the case of rejection of samples, one more chance will be given to OEM to prepare new sample, if the new sample is again rejected by WAPCOS/SAI, then the Contract will be terminated. OEM shall not cause any action or claim against the WAPCOS Ltd. for termination of his Contract.

The samples as approved during factory visit will be **signed by the members of WAPCOS/SAI** and all these samples will be preserved. These preserved samples will be transported at site in separate packing to match the bulk supplied furniture with the sample furniture at site. if finishing and quality of the bulk supplied furniture are not match with approved sample furniture, then whole lot will be rejected by the Engineer-in charge. If member of WAPCOS / SAI suggests some modification / colour scheme in the shown sample during visit same will be modified in the signed sample before sending to the site.

The approval of Sample by the WAPCOS/SAI does not means that OEM shall not be absolved of their responsibility regarding quality, materials used, manufacturing process, fixtures used, required test certificates as per specifications and other quality parameters mentioned in tender document.

The size of furniture mentioned in BoQ are on the basis of typical layout the rooms of hostel building. OEM shall also visit the each place of hostel building where furniture are to be installed , before start of the manufacturing of the furniture, as sizes of the furniture may vary as per the position of RCC column of building,. The OEM must be doubly sure about the size of the furniture as per the positions and actual room/ hall size before manufacturing & supply of proposed furniture Items. The Design of furniture of rooms shall be such that, it may not hinder with the electric switches already installed in the hostel & Studio Room. The modification in the size of the furniture as per the site locations & position of electric switches will be borne by OEM at their own cost and no additional payment will be done in this regard. The same shall be kept in consideration before quoting the cost of furniture items.

The WAPCOS reserve the right to inspect the OEM's factory/manufacturing unit from where the furniture is proposed to be manufacture, if required. OEM will be required to make necessary arrangement as per mutually agreed time and programme. The expenses of max. 4 nos. officials towards the travelling, boarding and lodging will be borne by the OEM. In case the WAPCOS & SAI does not sent their representative, the OEM will have to ensure that the material is fabricated/manufactured in compliance of Tender requirement and send their own representative to watch the manufacturing and tests so required to be carried out for the material.

Furniture are to be Manufactured/Supplied/installed as per the detail in attached bill of quantity, images and tender drawings. The quantity mentioned in BOQ may vary if any changes make by the client and as per the direction of SAI. If quantities are decreased/ increased, the unit rate quoted by OEM will be remain firm and final.

Selected OEM have to suggest modification in proposed furniture design/drawings according to experience of OEM for betterment and appearance which are equivalence to those designated in bill of quantity, images and tender drawings. OEM will submit detailed drawings and images of the furniture as per the modification suggested by OEM for approval from WAPCOS along with detail of quantity of material involved in furniture. The modification by OEM will only be entertained if agreed by SAI/WAPCOS. The modification may also be made by the WAPCOS as well as SAI within the specified weight after award of work.

The weight of steel considered, in related BOQ items are as per the weight of standard steel section considered in tender drawings as per following.

- 1) Steel weight considered in Study Table= approx. 12.50 KG
- 2) Steel weight considered in Dinning Table= approx. 25.50 Kg

If any modification in steel sections of furniture (shape & size) is suggested by selected OEMs/WAPCOS/SAI and approved as per the final drawings, the corresponding variation in weight of steel (+/-) will be added / deducted from quoted unit rate of particular item of furniture. The rate of deduction/ addition will be Rs. 400/- per kg.

The quantity mentioned in BOQ may vary if any changes make by the client and as per the direction of SAI. If quantities are decreased/ increased, the unit rate quoted by OEM will be remain firm and final.

3. Important point related to Quality of furniture

- As per tender conditions, all Mild Steel surface of furniture should be epoxy powder coated & oven baked at temperature above 200 degree Celsius to provide scratch resistant surface coating film of 45-50 micron thickness. After supply of furniture, the property of Powder coating **may be checked by NABL Accredited Laboratory (selected by WAPCOS) by random selection of any furniture item.** The cost of the testing will be born by the furniture agency.

- Each furniture item of each type of furniture should be packed in separate cartoons designed for particular furniture by OEM with proper use of Thermocol, Polythenes for the safety during transportation and keep the finishing as was in the factory at the time of finishing. **The loose furniture without any cartoon packing will be rejected and will be returned to OEM**
- Furniture **agency shall fix the 3D logo of OEM on each furniture item** manufactured at OEM factory. It is mandatory and furniture without the 3D logo of OEM will not be taken over, as logo of the OEM depicts the brand name and quality of furniture.
- Most of the furniture are to be made by branded HDHMR board, hence OEM is advised to see the relevant clauses related to HDHMR board and BoQ before quoting the cost.

1. Guarantee for Termite Free Furniture

The OEM shall be aware SAI, LNCPE Trivandrum area are **infested by termites**. Accordingly, in most of the furniture items **HDHMR (High Density High Moisture Resistance) Board** shall be used for manufacturing of furniture items. The OEM will take care termite issues during selection of the materials and at the time of manufacturing of furniture items. The OEM shall provide the Guarantee Bond for Anti termite treatment on Rs. 100 non- Judicial Stamp Paper duly attested by Notary / Magistrate for 05 years to be reckoned from the date after the Defect Liability Period. This Guarantee Bond for Anti termite treatment shall be submitted by OEM with final bill as per **Annexure-IV**.

The OEM will hand over the Sample piece of HDHMR Board of each thickness as per BoQ, which are being used by the OEM for manufacturing of the furniture, at the time of factory visit of Members of WAPCOS and SAI to keep in record. This sample piece will be matched randomly from any furniture items after supply of furniture at site. The member of SAI/ WAPCOS may also check the same by saw cutting of any randomly selected furniture item to check the quality as per the specification & sample provided during the factory visit.

2. Acceptable Makes for Furniture Material

Acceptable list of makes of materials to be used in manufacturing of particular furniture items are as below:

S.N	MATERIAL	MAKE
1	HDHMR Board/ Pre laminated HDHMR Board	Archidply, Century, Action Tesa, Duro
2	Plywood	Archidply, Century, Greenply, Merino, Duro
3	Laminates	Archidply, Century, Greenlam, Merino
4	Hinges/ Sliding Channels	Hettich, Ebco, Hafele, Ozone, Kich
5	Adhesive	Pidilite, Jivanjor, Araldite
6	Structural / Tubular Steel	Tata , Sail, RINL, Jindal, APL Apollo
7	Powder Coating Paint/Polish/ Primer	Akzonobel, Asian, Berger, Asian, Dulux, Nerolac, ICI

Annexure-IV

(On Rs. 100 non- Judicial Stamp Paper duly attested by Notary / Magistrate)

FORMAT FOR GUARANTE BONDS FOR ANTI-TERMITE TREATMENT
To Be Executed by Contractor for Anti Termite Treatment after Completion of Work

This Agreement made on this ____ day of _____ 20__ between_____ (Name of OEM & address) _____ (hereinafter called the OEM/ GUARANTOR of the one part) and the _____(hereinafter called Employer of the other part) for Anti Termite Treatment Works for Construction of 300 bedded hostel at SAI, LNCPE Trivandrum.

WHEREAS This Agreement is Supplementary, to a Contract (hereinafter called the Contract) Contract no. _____ dated _____ and made between the _____ (Name of Contractor) and WAPCOS LIMITED, 5th floor, Kailash Building, 26, K. G. Marg, New Delhi, whereby the contractor, inter alia, undertook to render the wooden work in the said contract recited completely Termite proof.

THE GUARANTOR hereby guarantee that the anti-termite treatment given by him will render the wooden works completely Termite proof and the minimum life of such Anti-Termite treatment shall be 05 (five) years to be reckoned from the date after the Defect Liability Period whichever is later, prescribed in the contract.

During the period of guarantee the Guarantor shall make good all defects and in case of any defects being found render the wooden works termite proof to the satisfaction of the Employer at his cost and shall commence the work for such rectification within seven days from the date of issue of notice from the Employer calling upon him to rectify the defects, failing which the work shall be got done by the Employer through some other Agency at the Guarantor’s cost and risk. The decision of the Employer as to the cost payable by the Guarantor shall be final and binding.

That if the guarantor fails to execute the Anti-termite works, or commits breach thereunder then the guarantor will indemnify the and his successor against all loss, damage, cost of expenses or otherwise which may be incurred by him by reason of any of any default on the part of the GUARANTOR in performance and observance of this Supplementary Agreement. As to the amount of loss and / or cost incurred by the Employer on the decision of the Employer will be final and binding.

IN WITNES WHEREOF those presents have been executed by the GUARANTOR(Name and Designation who sign the Contract) on behalf of(Name of OEM) and Employer on the day, month and year first above written.

SIGNED, SEALED AND DELIVERED

For and on behalf of the OEM	For and on behalf of the Employer
-------------------------------------	--

NAME _____
 Designation _____

NAME _____
 Designation _____

in the presence of witness:

in the presence of Witness

1 _____

1 _____

2 _____

2 _____

SECTION – VI

TENDER DRAWINGS / IMAGES

Manufacturing, Supply and Installation of Furniture for 300 Bedded Hostel at SAI, Trivandrum

Hostel Room

SINGLE BED WITH BOX (WITHOUT MATTRESS) – 318 Nos.

Supported on Mild Steel CRCA Mild Steel frame of size 25X25X1.2mm thick



OR



**Inside Mild Steel CRCA frame
for Single bed**



ROOM VISITOR CHAIR -312 Nos.



Colour will be finalised by SAI / WAPCOS

Study Table- 312 Nos.



- Mild Steel Frame and Drawer
- Scratch Resistant Powder Coating
- SIZE: (900 X 450 X 750) MM
- Wt. of Steel- 12.50 Kg
- 18mm thick Pre-laminated HDHMR Board (Both Side)

Colour Scheme will be finalised by SAI / WAPCOS

Note: Other Dimensions & detailing shall be as per BoQ

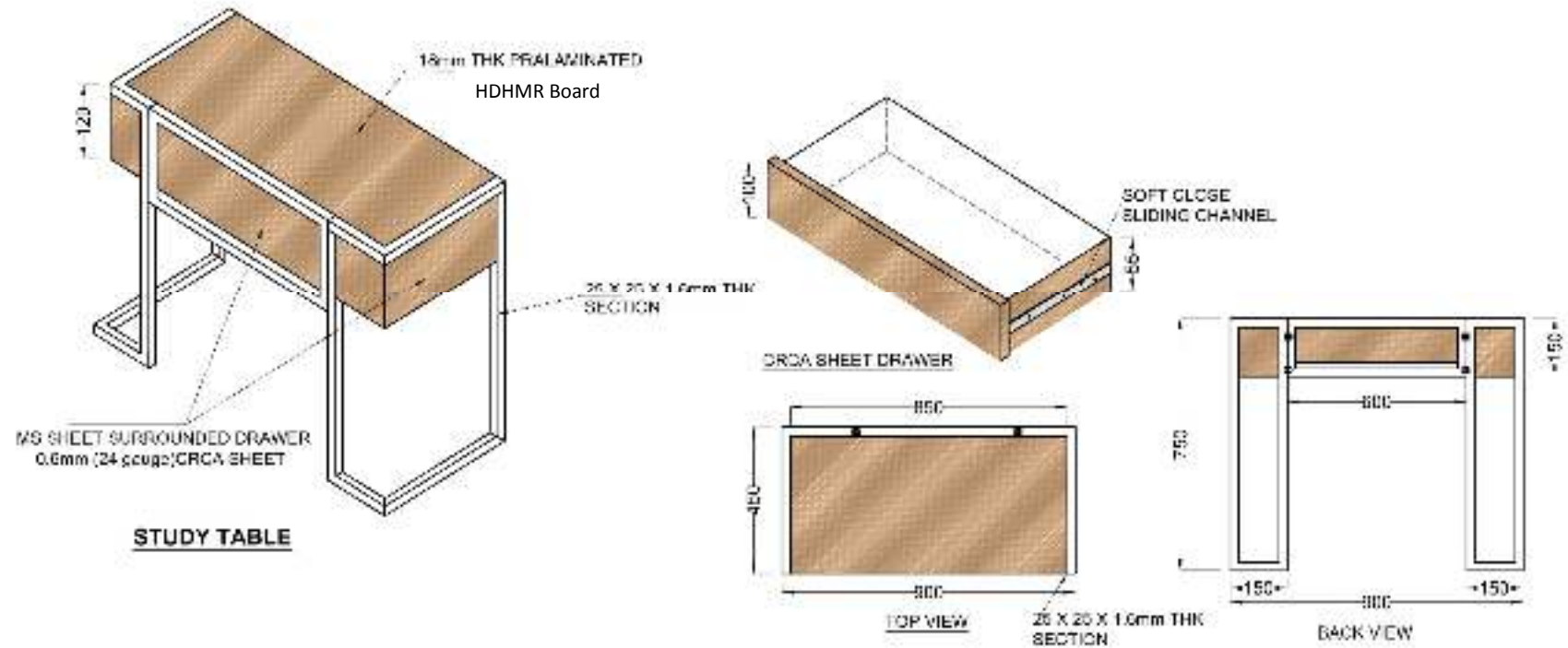

 <p>WAPCOS Ltd. (A GOVERNMENT OF INDIA UNDERTAKING)</p>		
<p>Sports Authority of India</p>		
<p>Drawn by: FURNITURE FOR HOSTELS</p>		
DATE: 20/07/2011	SCALE: 1:1	DRG NO: 2

Studio Rooms

STUDIO ROOM KING SIZE BED -18 Nos.

Supported on Mild Steel CRCA Mild Steel frame of size 25X25X1.2mm thick or More



OR



OR



Sample King size Bed with box
Half Pull-Out Drawer Storage + Half Manual Lift-up Storage



OR



OR



Sample images of Side Table

(Matching with selected king size bed at the time of factory visit)

Colour scheme will be finalised by SAI / WAPCOS

STUDIO ROOM STUDY TABLE- 18 Nos.



OR



Study Table

Colour scheme will be finalised by SAI / WAPCOS

STUDIO ROOM VISITOR CHAIRS - 18 Nos.



Colour will be finalised by SAI / WAPCOS

STUDIO ROOM SOFA- 18 Nos.



Colour scheme will be finalised by SAI / WAPCOS

STUDIO ROOM COFFEE TABLE- 18 Nos.

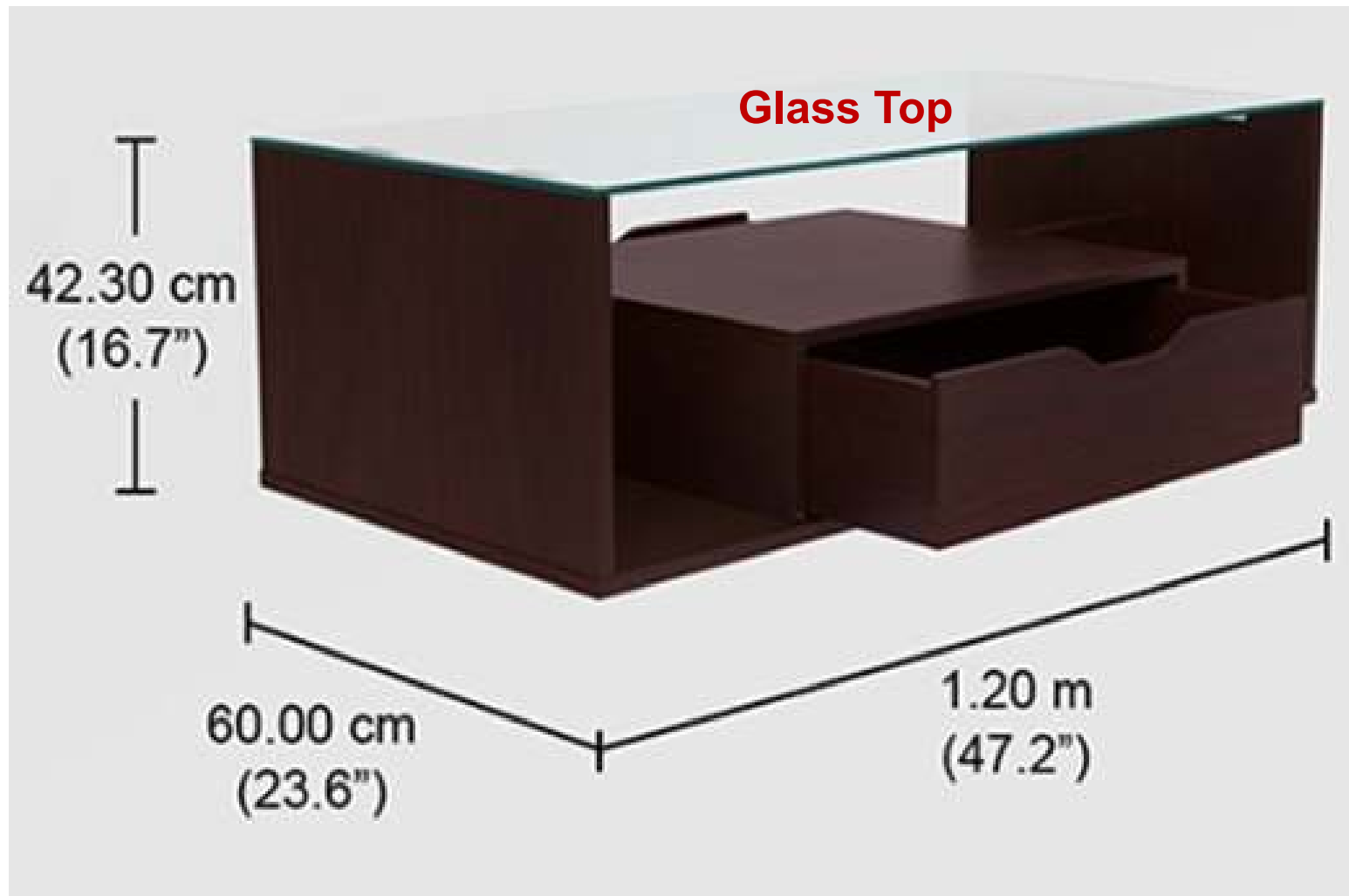

Colour scheme will be finalised by SAI / WAPCOS

Reception Furniture

Reception Table with Chair -1 No.

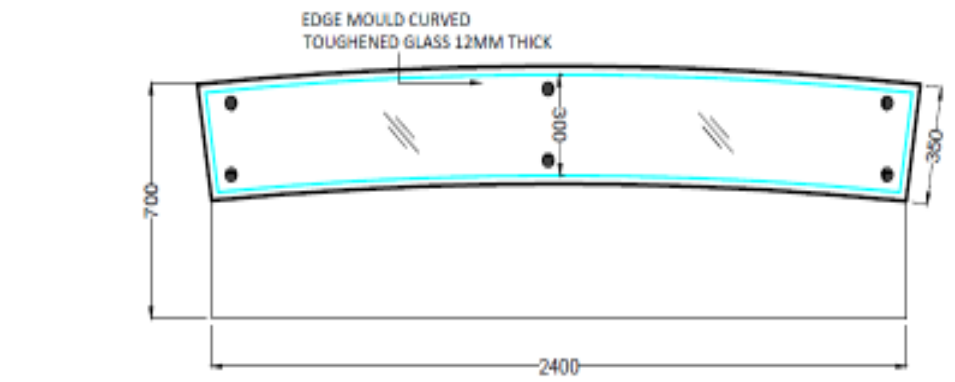

PLAN VIEW

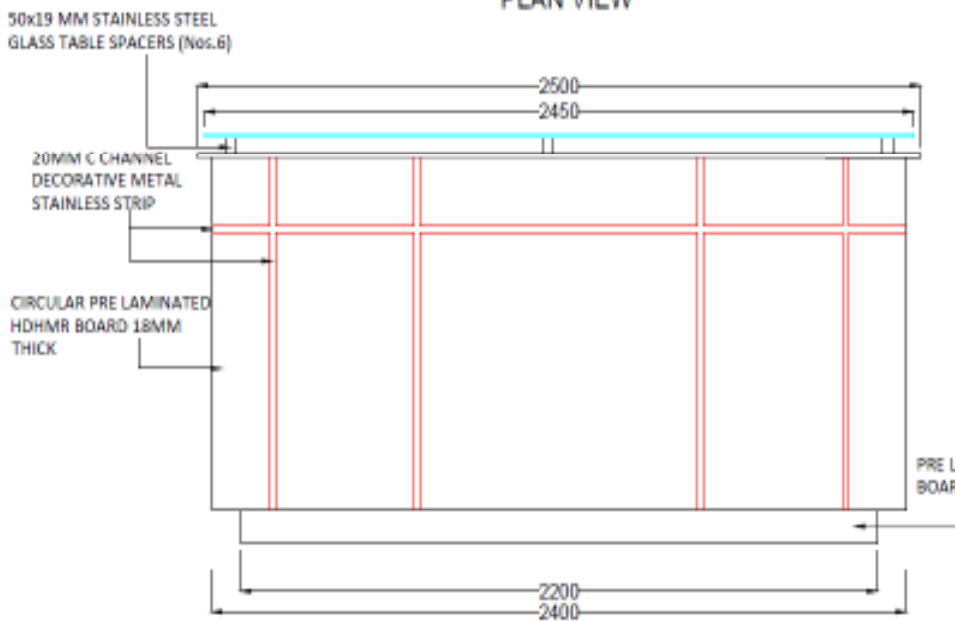

FRONT VIEW
OF RECEPTION TABLE

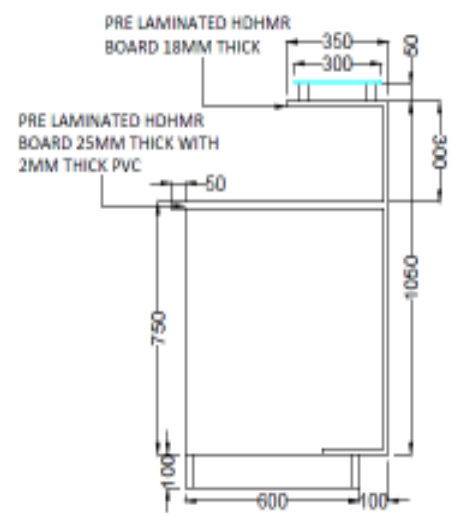

SIDE VIEW

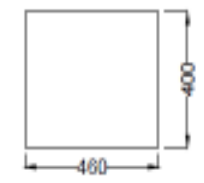

PLAN VIEW

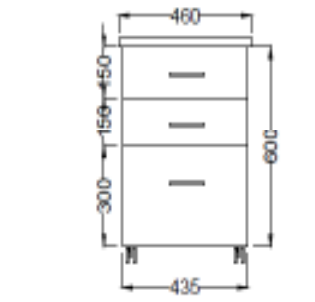

FRONT VIEW
OF MOVABLE PEDESTAL



Reception
Chair

NOTE:-
1) Other detail as per BOQ
2) All Dimensions are in mm



Reception Table

SOFA SETS: 3 Seater-2 nos. and 1 seater – 4nos.



Colour scheme will be finalised by SAI / WAPCOS

RECEPTION COFFEE TABLE – 2 Nos.



Colour scheme will be finalised by SAI / WAPCOS

Dinning Hall Furniture

DINING TABLE – 18 Nos.



- Mild Steel Frame
- Scratch Resistant Powder Coating
- SIZE: (2200 X 900 X 750) MM
- Wt. of Steel- 25.50 Kg
- 18mm thick Granite top with Double edge moulding having 12mm Ply below

DINNING TABLE

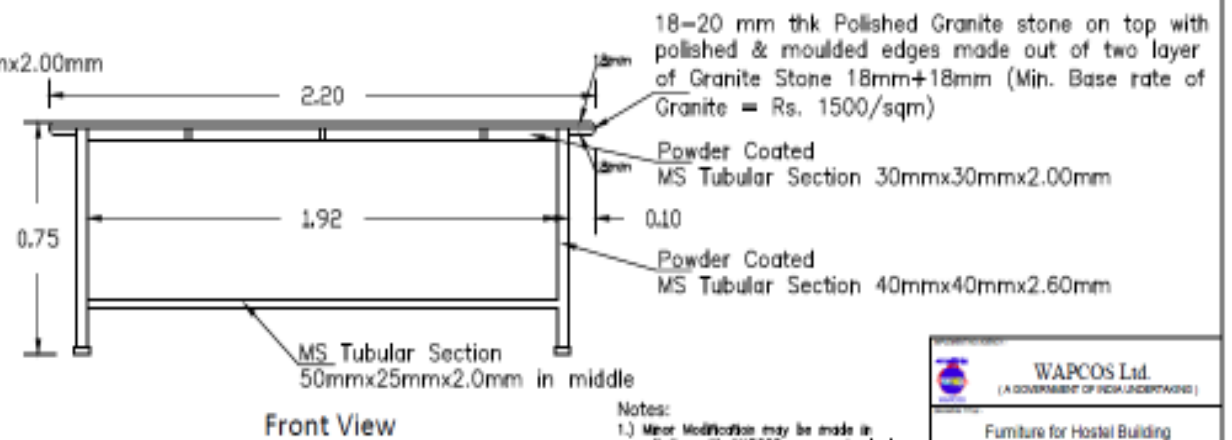
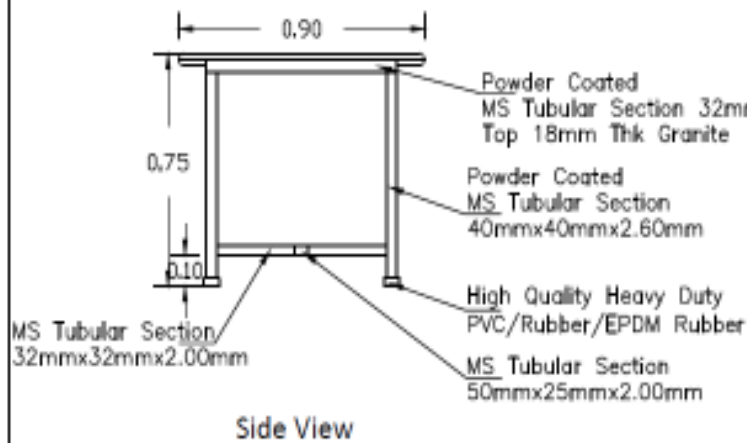
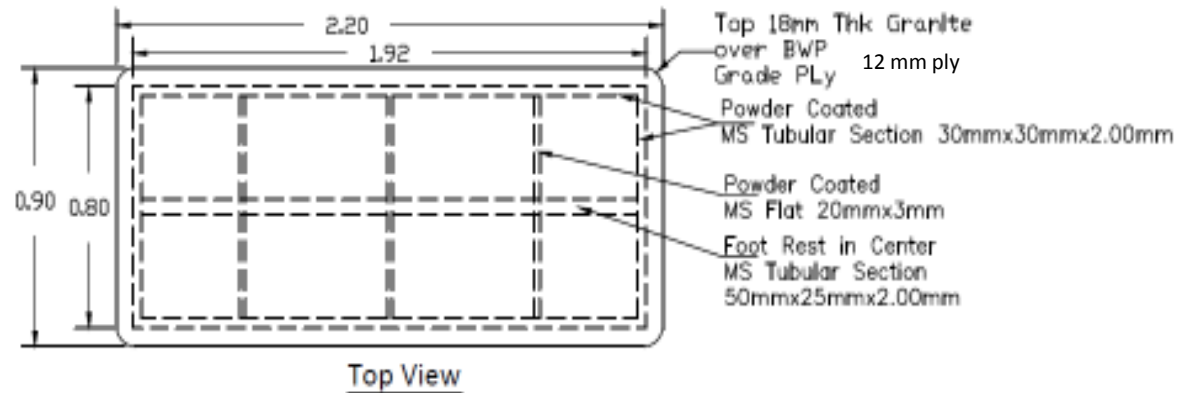

- Notes:
- 1.) Minor Modification may be made in consultation with WAPCOS as per standard size, feasibility and practice without any extra charges and cost to work.
 - 2.) Drawing not to the scale.

 WAPCOS Ltd. <small>(A GOVERNMENT OF INDIA UNDERTAKING)</small>	Furniture for Hostel Building
	Dining Table Details

DINING HALL CHAIR-108 Nos.



OR



OR



Sample of Premium Hybrid Chair with Polypropylene seat & SS Legs without Arms Chair

Colour & Type will be finalised by SAI / WAPCOS

SECTION– VII

FINANCIAL PROPOSAL

Section-VII

Financial Proposal

The Detailed Bill of Quantity for the work Manufacturing, Supply and Installation of Furniture for 300 Bedded Hostel at SAI, LNCPE Trivandrum is given in next page :

Note regarding fill of Financial Proposal on GeM Portal: -

- The Rate up to zero decimal place is to be filled in GeM Portal.
- Quoted rates by the OEM shall be firm during the performance of the Contract. Quoted amount by the OEM with any condition shall not be accepted and same is liable to be rejected. Rates quoted by the OEM shall include all Materials, Tools & Plant, labour, supervision, profit; other levies together with all general risks, liabilities and obligations set out or implied in the contract, applicable Labour Cess, cost of insurance to this contract, all applicable tax liabilities like Income Tax & Surcharges, etc. Any other taxes /cess as per Government directives shall be deducted from each bill paid to the OEM, from time to time. GST shall be payable extra as per prevailing rates.
- It is mandatory to OEMs to deposit GST within time limit framed by Govt. of India, if applicable. The Goods and Services Tax (GST), shall be reimbursed to the Agency only after uploading of bills by OEM on GST Portal “to avail Input benefit of GST”.
- The OEM shall submit e-invoice / Tax Invoice (as applicable for the OEM) to WAPCOS showing (i) Basic amount (ii) GST amount separately in each bill. It is mandatory to OEMs to deposit GST within time limit framed by Govt. of India, if applicable. The Goods and Services Tax (GST), shall be reimbursed to the Agency only after uploading of bills by OEM on GST Portal “to avail Input benefit of GST”.
- The WAPCOS shall be performing all its duties of deduction TDS and other deduction on payment made to the OEM as per applicable legislation in force on the date of submission of bid or to be newly / amended introduced during the execution of the Contract.
- The OEM will submit **Tax Invoice** for the completed works of furniture as per tender condition. The **Tax Invoice** will be billed to WAPCOS limited, 3rd floor, Chacko Towers, Jew Street, Pullepady, Ernakulam, Kochi, Kerala with WAPCOS GSTIN/ UIN no. 32AAACW0764A2ZX.

Detailed Bill of Quantity

Supply & Installation of furniture for 300 Bedded Hostel at SAI LNCPE Trivandrum

SN	Specification of Furniture items	Unit	Qty.	Assessed rate including GST	Amount including GST
A	Hostel Room + Dormitory				
1	<p>Manufacturing, Supplying and installation of Premium Hostel Room Single Bed with Box : Manufacturing, Supplying and installation of Single Bed with provision of Manual Lift-up Storage of modern design wood delightful look with elegant headboard of size 2071 (L) x 940 (W) x 1082 (H) (mm), Suitable Bed base height from the floor for 8” or thicker mattress, with inside CRCA Mild Steel tube of size 25X25X1.2mm thick. CRCA Mild Steel tube shall be assembled with precise Laser Welding and with good quality Nuts & Bolts with the satisfaction of WAPCOS. The MS Steel used shall be treated by epoxy powder coating and oven baked at temperature above 200 degree Celsius to provide scratch resistant surface coating film of 45-50 micron thickness.</p> <p>The length of bed 2071 mm & width of bed may be increased/ decreased as per the design of head board and tail board, therefore, length of bed should be such that, so 6 feet 6 inches mattress shall be fitted on the bed. If the length & width increase by +10% due to design of head board and tail board no additional payment will be made. The clear depth of storage box will be minimum 360mm +/- 10%.</p> <p>High grade 25 mm thick designer pre laminated HDHMR Headboard (total height-1082mm from floor) and 18 mm thick elegant designer pre laminated HDHMR Tailboard (total height -550 mm from floor) shall be used. Bed side structure are made of minimum 18mm thick pre-laminated HDHMR Board matching with Headboard & Tailboard. Moulding should be provided on all the three sides of head board and polished matching with bed colour. The mattress panel shall be made of minimum 18 mm thick Pre-laminated HDHMR Board finished on both sides. 12 mm thick pre laminated HDHMR Board shall be fixed to support the mattress between the frame. Bottom panels under the storage of bed shall be made of minimum 12 mm thick pre laminated HDHMR Board finished on both sides. All exposed edges edge banded with 2mm thick PVC edge banding tape using with special hot melt glue at hot temperature by PVC power press machine. All four legs provided with High Quality Heavy Duty PVC/ Rubber/EPDM Rubber. The design will be as per the Image and no changes will be allowed without the approval of WAPCOS/ SAI. The colour of laminate will be finalised by the SAI / WAPCOS matching with the interior of hostel room.</p> <p><u>The specification / design of this furniture item will be governed in conjunction with as detailed here in BoQ and Images. The options for this items of furniture are also given in the Section-VI of “Tender Drawings / Images”, therefore if client select any one option, then specifications given in the BOQ shall be modified by OEM as per the image selected by client and no additional cost in this regard will be paid to the OEM. Hence OEMs are advised to quote the rate accordingly</u></p> <p>Note: All the cutting/ bending shall be done by CNC pipe/ tube bending & cutting machine only and finishing by relevant equipped machineries. The Powder coating shall be done thorough fully automated powder coated plant with conveyer</p>	Nos.	318	20696	65,81,328

SN	Specification of Furniture items	Unit	Qty.	Assessed rate including GST	Amount including GST
	facility, baking oven, Powder applicator with 9-11 tank pre treatment mechanism to achieve scratch resistant surface coating film of 50-60 micron thickness.				
2	<p>Supplying & Installation of Hostel Room Premium Visitor Chair with Seat/back assembly: the seat and back should be made up of 1.2 ±0.1cm. thick hot-pressed plywood and upholstered with .fabric upholstery covers and moulded polyurethane foam. the back foam should be designed with contoured lumbar support for extra comfort. the seat has extra thick foam on front edge to give comfort to popliteal should be a. back size 47.5 cm. (w) x58.0 cm (h)seat size 47.0 cm. (w) x 48.0 cm. (d) .high resilience (hr) polyurethane foam: the hr polyurethane foam should be moulded with density = 45±2 kg/m³ and hardness load 16 ± 2 kgf for 25% compression. 3. 3.armrests :the one-piece armrests should be injection moulded from black co-polymer polypropylene. tubular frame: the powder coated (dft 40-60 microns) tubular frame should be cantilever type & made of 0 2.54 ±0.03cm. x 0.2 ±0.016cm.thk. m.s. er.w. tube. The design will be as per the Image and no changes will be allowed without the approval of WAPCOS/ SAI. The colour of fabric used in the chair will be decided by SAI/WAPCOS. The design will be as per the Image OR as finalised by the SAI / WAPCOS during Site Visit. No additional cost due to change of design will be made.</p> <p>Note: All the cutting/ bending shall be done by CNC pipe/ tube bending & cutting machine only and finishing by relevant equipped machineries. The specification / design of this furniture item will be governed in conjunction with as detailed here in BoQ and Images.</p>	Nos.	312	8698	27,13,776
3	<p>Manufacturing, Supply and Installation of Study Table of size 900 x 450 x 750 mm with CRCA sheet drawer of full length and width with soft close sliding channel as per the attached drawings & image. The Structural Steel / drawer used shall be assembled with precise robotic Laser Welding automation machine and with good quality Nuts & Bolts with the satisfaction of WAPCOS. The MS Steel used shall be treated by epoxy powder coating and oven baked at temperature above 200 degree Celsius to provide scratch resistant surface coating film of 50-60 micron thickness. Top panel and assembly shall made of 18 mm thick Pre- laminated HDHMR Board. All the exposed edges are edge banded with 2 mm thick PVC edge banding Tape using with special hot melt glue at hot temperature by PVC power press machine. All four legs provided with High Quality Heavy Duty PVC/ Rubber/EPDM Rubber</p> <p>Note: All the cutting/ bending shall be done by CNC pipe/ tube bending & cutting machine only and finishing by relevant equipped machineries. The Powder coating shall be done thorough fully automated powder coated plant with conveyer facility, baking oven, Powder applicator with 9-11 tank pre treatment mechanism to achieve scratch resistant surface coating film of 50-60 micron thickness. All the cutting of engineering wood by sliding panel saw machine, laminating by Laminate hot press power machine, PVC edge banding taping by PVC power press machine, wood works by spindle modular wood machine, shall be done for manufacturing of furniture. The specification / design of this furniture item will be governed in conjunction with as detailed here in BoQ and Images.</p>	Nos.	312	8614.000	26,87,568
B	STUDIO ROOM				

SN	Specification of Furniture items	Unit	Qty.	Assessed rate including GST	Amount including GST
4	<p>Manufacturing, Supplying and installation of King Size Storage Bed with <u>Half Pull-Out Drawer Storage + Half Manual Lift-up Storage</u>, modern delightful look with elegant headboard of size 2071 (L.) x 1875 (W) x 1082 (H) (mm), with inside CRCA Mild Steel tube of size 25X25X1.2mm thick. CRCA Mild Steel tube shall be assembled with precise Laser Welding and with good quality Nuts & Bolts with the satisfaction of WAPCOS. The MS Steel used shall be treated by epoxy powder coating and oven baked at temperature above 200 degree Celsius to provide scratch resistant surface coating film of 45-50 micron thickness.</p> <p>The length of bed 2071 mm & width of 1875 mm may be increased as per the design of head board and tail board, therefore, length of bed should be such that, so 6 feet 6 inches mattress shall be fitted on the bed. If the length & width increase by +10% due to design of head board and tail board no additional payment will be made.</p> <p>Suitable Bed base height from the floor for 8” or thicker mattress, High grade 25 mm thick designer pre laminated HDHMR Head board (total height -1082 mm from floor) with shelves (Clear depth 150mm) as shown in the image and 18 mm thick elegant designer pre laminated HDHMR Tailboard (total height -550 mm from floor) shall be used. Bed side structure are made of minimum 18mm thick pre-laminated HDHMR Board matching with Headboard & Tailboard. Moulding should be provided on all the three sides of head board and polished matching with bed colour.</p> <p>The mattress panel shall be made of minimum 12 mm thick Pre-laminated HDHMR Board finished on both sides. Bottom panels under the storage of bed shall be made of minimum 12 mm thick pre laminated HDHMR Board finished on both sides. All exposed edges edge banded with 2mm thick PVC edge banding tape using with special hot melt glue at hot temperature by PVC power press machine. All four legs provided with High Quality Heavy Duty PVC/ Rubber/EPDM Rubber. The design will be as per the Image and no changes will be allowed without the approval of WAPCOS/ SAI. The colour of laminate will be finalised by the SAI / WAPCOS matching with the interior of hostel room.</p> <p><u>The specification / design of this furniture item will be governed in conjunction with as detailed here in BoQ and Images. The options for this items of furniture are also given in the Section-VI of “Tender Drawings / Images”, therefore if client select any one option, then specifications given in the BOQ shall be modified by OEM as per the image selected by client and no additional cost in this regard will be paid to the OEM. Hence OEMs are advised to quote the rate accordingly</u></p> <p>Note: All the cutting by sliding panel saw machine, laminating by Laminate hot press power machine, PVC edge banding taping by PVC power press machine, wood works by spindle modular wood machine, shall be done for manufacturing of furniture. The Powder coating shall be done thorough fully automated powder coated plant with conveyer facility, baking oven, Powder applicator with 9-11 tank pre treatment mechanism to achieve scratch resistant surface coating film of 50-60 micron thickness.</p>	Nos.	18	41300.000	7,43,400
5	<p>Manufacturing, Supplying and Installation of Bed Side Table of size W x H x D - 460mm x 510mm x 461mm matching with the family of proposed king size bed of 18mm thick pre laminated HDHMR Board with modern design and elegant</p>	Nos.	18	8141.000	1,46,538

SN	Specification of Furniture items	Unit	Qty.	Assessed rate including GST	Amount including GST
	<p>aesthetics. Provision for one open shelf and one drawer with sliding channels as per image. The working or non-working edges shall be provided with matching 2mm thick PVC edging tape using with special hot melt glue at hot temperature by PVC power press machine. Drawer with fancy handles having soft closed with long telescopic channel with locking system & necessary hardware/ fitting/ hinges etc. of approved quality. Table shall rest on High Quality Heavy Duty PVC/ Rubber/EPDM Rubber. The design will be as per the Image and no changes will be allowed without the approval of WAPCOS/ SAI.</p> <p><u>The specification / design of this furniture item will be governed in conjunction with as detailed here in BoQ and Images. The options for this items of furniture are also given in the Section-VI of “Tender Drawings / Images”, therefore if client select any one option, then specifications given in the BOQ shall be modified by OEM as per the image selected by client and no additional cost in this regard will be paid to the OEM. Hence OEMs are advised to quote the rate accordingly</u></p> <p>Note: All the cutting by sliding panel saw machine, laminating by Laminate hot press power machine, PVC edge bidding by PVC power press machine, wood works by spindle modular wood machine, shall be done for manufacturing of furniture.</p>				
6	<p>Manufacturing, Supplying and Installation of Studio Room Study Table of size 1200 Width x 600 Depth x 743 Height . Top shall be of 18 mm thickness made of pre-laminated HDHMR top board with surrounding double edge moulding of 36mm (18mm +18mm) covered with 2 mm thk. edge banding tape of 36mm width. <u>The Understructure shall be in pre-laminated panels made with pre-laminated HDHMR Board.</u> The side panel /back panel/ vertical support and modesty shall be made out of 18mm thick Pre-laminated HDHMR board and shall be supporting below the working table top and modesty having height of 650 mm to 700 mm shall be fixed at front side of table top. All necessary hardware/ fitting etc. shall be of higher quality & reputed make. Table shall have minimum three drawer unit with central locking facilities and adequate provisions for the movement of electric/ data cables at desired levels and for installation of table wooden dowels and mini fix to use for additional support. Provision of Metal Keyboard which runs on telescopic channel & CPU trolley with lockable castors for smooth operation on floor. Table shall rest on High Quality Heavy Duty PVC/ Rubber/EPDM Rubber. The design will be as per the Image and no changes will be allowed without the approval of WAPCOS/ SAI.</p> <p><u>The specification / design of this furniture item will be governed in conjunction with as detailed here in BoQ and Images. The options for this items of furniture are also given in the Section-VI of “Tender Drawings / Images”, therefore if client select any one option, then specifications given in the BOQ shall be modified by OEM as per the image selected by client and no additional cost in this regard will be paid to the OEM. Hence OEMs are advised to quote the rate accordingly</u></p> <p>Note: All the cutting by sliding panel saw machine, laminating by Laminate hot press power machine, PVC edge bidding by PVC power press machine, wood works by spindle modular wood machine, shall be done for manufacturing of furniture.</p>	Nos.	18	16284.000	2,93,112

SN	Specification of Furniture items	Unit	Qty.	Assessed rate including GST	Amount including GST
7	<p>Supplying & Installation of Hostel Room Premium Visitor Chair with Seat/back assembly: the seat and back should be made up of 1.2 ±0.1cm. thick hot-pressed plywood and upholstered with fabric upholstery covers and moulded polyurethane foam. the back foam should be designed with contoured lumbar support for extra comfort. the seat has extra thick foam on front edge to give comfort to popliteal should be a. back size 47.5 cm. (w) x58.0 cm (h)seat size 47.0 cm. (w) x 48.0 cm. (d) .high resilience (hr) polyurethane foam: the hr polyurethane foam should be moulded with density = 45±2 kg/m³ and hardness load 16 ± 2 kgf for 25% compression. 3. 3.armrests :the one-piece armrests should be injection moulded from black co-polymer polypropylene. tubular frame: the powder coated (dft 40-60 microns) tubular frame should be cantilever type & made of 0 2.54 ±0.03cm. x 0.2 ±0.016cm.thk. m.s. er.w. tube. The design will be as per the Image and no changes will be allowed without the approval of WAPCOS/ SAI. The colour of fabric used in the chair will be decided by SAI/WAPCOS. The design will be as per the Image OR as finalised by the SAI / WAPCOS during Site Visit. No additional cost due to change of design will be made.</p> <p>Note: All the cutting/ bending shall be done by CNC pipe/ tube bending & cutting machine only and finishing by relevant equipped machineries. The specification / design of this furniture item will be governed in conjunction with as detailed here in BoQ and Images.</p>	Nos.	18	8697.000	1,56,546
8	<p>Manufacturing, Supplying and Installation of Premium Quality Modernist Classic Design Lounge 2 seater Sofa Manufacturing, Supplying and Installation of Premium Quality Modernist Classic Design Lounge 2 seater Sofa of size (L) :1.57 m , (D) 0.89 m and back height of 0.975 m as per the image 2 Seater Sofa Set</p> <ul style="list-style-type: none"> • Understructure: Understructure of seat is made up of combination of pinewood members and 12mm thick Plywood. Pinewood are of cross sections 34x64mm, and 16x30mm without having major knots & defects on the surface Complete understructure of Seat is made by gluing, nailing & stapling, Non-woven fabric of 100GSM is stapled on the top surface after attaching Zig-Zag spring to cover the structure. • Foam: Foaming of seat is done with and 28kg/m³ PU foam. A top layer of supemoft PU foam with density 32 kg/m³ is used to provide softness. . Armrest : <ul style="list-style-type: none"> • Understructure: Understructure of armrest is made up of combination of pinewood members,12mm thick Plywood. Pinewood are of cross sections 16X35mm without having major knots & defects on the surface. Complete undemtructure of Armrest is made by gluing, nailing & stapling.Rubber wood panel 18mm to be fitted just after the upholstery is done or before assembling the armrest • Foam: Foaming of Armrest is done with density 60kg/m³ and 28kg/m³ on all the outer surfaces in order to give definition to the form of armrest.Foam of 28kg/m³ is used on the top surface of armrest. • FACIA PANEL: Facia panel is having wood-stain matt finish. It is fitted to the armrest with the help of Velcro-strip. <p>3. Backrest : (1 Seater, 2 Seater, 3 Seater)</p>	Nos.	18	52038.000	9,36,684

SN	Specification of Furniture items	Unit	Qty.	Assessed rate including GST	Amount including GST
	<ul style="list-style-type: none"> • Understructure: Understructure is made up of combination of pinewood members, 12mm THK Plywood, HDPE sheet at the rear side of the backrest at the bottom side of the backrest ear Pinewood are of cross sections 16x35, 22x64mm, 22x40mm without having major knots and defects on the surface. HDPE sheet is to be stapled on the rear side of backrest. • Foam: Backrest is made of PU foam with density 60kg/m[^] and 28kg/m* and 32kg/m3. Backrest Lumber foam is of 32kg/m covered with layer's of recron sheet of 200gsm. Cushion :(1 Seater, 2 Seater, 3 Seater) Backrest neck cushion are in the form of detachable pillows which are connected with the help of Velcro strip of (2 inch). Backrest cushion consist of 50mm thk 32density PU foam and wrapped with layer of 200gsm recron sheet. <p>5.Upholstery: For color combination please fefer latest color chart as there are single-tone as well as dual-tone option for Leatherite fabric.</p> <p>The design will be as per the Image and no changes will be allowed without the approval of WAPCOS/ SAI.</p> <p>Note: All the cutting of natural wood by sliding panel saw machine, and spindle modular wood machine, Leather cutting by CNC Cutting & stitching machine, shall be done for manufacturing of furniture. If necessary WAPCOS/SAI will show the physical sample of the 2 seater sofa as already installed in various SAI centres, so that same Sofa may be supplied as shown in image. The specification / design of this furniture item will be governed in conjunction with as detailed here in BoQ and Images.</p>				
9	<p>Manufacturing, Supplying and Installation of Premium Quality Modernist Classic Design Coffee Table for Studio Room of size 1200mm L x600mm W X423mm H. The structure of Coffee table should be made 18mm thick pre laminated HDHMR board and exposed edges shall be protected with 0.8mm-1mm thick PVC edge banding tape affixed with hot melt glue by PVC power press machine. Top is made of 12mm toughened clear glass with configuration of shelf storage, display space and dual drawer conceled storage as shown in the image.</p> <p>Note: All the cutting of natural wood / engineering wood by sliding panel saw machine, and spindle modular wood machine, shall be done for manufacturing of furniture. The specification / design of this furniture item will be governed in conjunction with as detailed here in BoQ and Images and no changes will be allowed without the approval of WAPCOS/ SAI. All the cutting of engineering wood by sliding panel saw machine, and spindle modular wood machine, shall be done for manufacturing of furniture.</p>	Nos.	18	18998.000	3,41,964
C	Reception Area				
10	<p>Manufacturing, Supplying & Installation of Modern Design Reception Desk in engineered wood delight design spacious curved shape reception desk, of size 2400mm L x 700mm D (working top) x 1050mm Height as per the drawing & Image attached in the section of Drawings with high quality finishing and attached with all the required accessories with</p>	Nos.	1	37995.000	37,995

SN	Specification of Furniture items	Unit	Qty.	Assessed rate including GST	Amount including GST
	<p>top 12mm thick curved toughed Glass Working top of the table should be made out of 25mm thick pre-laminated HDHMR Board. All exposed edges should be protected with 2mm thick PVC edge banding tape and affixed with hot melt glue by PVC power press machine. Vertical supports and modesty panel should be made out of 18 mm thick pre-laminated HDHMR Board and exposed edges shall be protected with 0.8mm-1mm thick PVC edge banding tape affixed with hot melt glue by PVC power press machine. A top shelf of 300mm width is to be provided on the working top keeping clear gap 275mm. Top shelf should be made out of 25mm thick pre-laminated HDHMR Board, all exposed edges should be protected with 2mm thick edge banding tape affixed with holt melt glue by PVC power press machine. Reception table should be provided with 2nos pedestal unit having 3-drawers having sliding channels with central locking facilities decorative handles and all other required accessories. Table shall rest on High Quality Heavy Duty PVC/ Rubber/EPDM Rubber. The design will be as per the Image and no changes will be allowed without the approval of WAPCOS/ SAI.</p> <p>Note: All the cutting by sliding panel saw machine, laminating by Laminate hot press power machine, PVC edge bidding by PVC power press machine, wood works by spindle modular wood machine, shall be done for manufacturing of furniture. The specification/design of this furniture item will be governed in conjunction with as detailed here in BoQ and Images.</p>				
11	<p>Manufacturing, Supplying and installation of Premium Quality Classic Design 3 Seater Sofa of Length: 1930mm, Depth: 790mm, Seat Height: 425mm, Back height from floor level: 780mm (Tolerance +/-10mm). Main outer frame structure should be made out of 25dia 1.2mm thick stainless steel of 202 Grade. Understructure of sofa should be made of 11mm thick & 15 ply. Arms should be made of 8mm thick and 17mm thick board. Seat cushioning should be 100mm and 25mm for arms and back. Seat and back should be provided with nylon strips below the cushioning. PU foam to be used for cushioning arms & back. High quality Rexene or leatherite (Weight 550-750 GSM; thickness 1.1 mm to 1.4 mm & martin dale 1.25 lakhs cycle) should be used as upholstery. The design will be as per the Image OR as finalised by the SAI / WAPCOS during Site Visit. No additional cost due to change of design will be made.</p> <p>Note: All the cutting/ bending shall be done by CNC pipe/ tube bending & cutting machine only and finishing by relevant equipped machineries. Rexene or leatherette cutting by CNC Cutting & stitching machine, shall be done for manufacturing of furniture. The specification / design of this furniture item will be governed in conjunction with as detailed here in BoQ and Images.</p>	Nos.	2	38674.000	77,348
12	<p>Manufacturing, Supplying and installation of Premium Quality Classic Design single Seater Sofa of Length: 920mm, Depth: 790mm, Seat Height: 425mm, Back height from floor level: 780mm (Tolerance +/-10mm). Main outer frame structure should be made out of 25dia 1.2mm thick stainless steel of 202 Grade. Understructure of sofa should be made of 11mm thick & 15 ply. Arms should be made of 8mm thick and 17mm thick board. Seat cushioning should be 100mm and 25mm for arms and back. Seat and back should be provided with nylon strips below the cushioning. PU foam to be used for cushioning arms & back. High quality Rexene or leatherette (Weight 550-750 GSM; thickness 1.1 mm to 1.4 mm & martin dale 1.25 lakhs cycle) should be used as upholstery. The design will be as per the Image OR as finalised by the SAI / WAPCOS during Site Visit. No additional cost due to change of design will be made.</p>	Nos.	4	14925.000	59,700

SN	Specification of Furniture items	Unit	Qty.	Assessed rate including GST	Amount including GST
	<p>Note: All the cutting/ bending shall be done by CNC pipe/ tube bending & cutting machine only and finishing by relevant equipped machineries. Rexene or leatherette cutting by CNC Cutting & stitching machine, shall be done for manufacturing of furniture. The specification / design of this furniture item will be governed in conjunction with as detailed here in BoQ and Images.</p>				
13	<p>Manufacturing, Supplying and Installation of Premium Quality Modernist Classic Design Center Table of size 1000mm L x550mm W X450mm H. The Centre table should be made up of combination of rubber wood legs and surrounding Top & bottom structure of 18mm thick Pre laminated HDHMR Board. Top is made of 12mm glass toughened. The legs shall be of solid Rubber wood, having square cross section 120 x 120 made out of first quality solid rubber wood. One shelf provided below the top should be made of 12mm thick pre laminated HDHMR board for books or magazines. All the wooden members/ engineering wood members shall be finished with wooden grain finish high quality 4 layer High quality melamine polish on all surface including preparing of surface by sand papering, applying putty etc. complete. All exposed edges edge banded with 2mm thick PVC edge banding tape using with special hot melt glue at hot temperature by PVC power press machine The design will be as per the Image and no changes will be allowed without the approval of WAPCOS/ SAI.</p> <p>Note: All the cutting of natural wood / engineering wood by sliding panel saw machine, and spindle modular wood machine, shall be done for manufacturing of furniture. The specification / design of this furniture item will be governed in conjunction with as detailed here in BoQ and Images.</p>	Nos.	2	12891.000	25,782
14	<p>Manufacturing, Supplying and installation of seat/back assembly Revolving chair consisting of the seat and back should be made up of 1.2 ±0.1cm. thick hot-pressed plywood and upholstered with fabric upholstery covers and moulded polyurethane foam with contoured lumbar support for extra comfort. the seat has extra thick foam on front edge to give comfort to popliteal should be a. back size 47.5 cm. (w) x58.0 cm (h)seat size 47.0 cm. (w) x 48.0 cm. (d) .high resilience (hr) polyurethane foam: the hr polyurethane foam should be moulded with density = 45±2 kg/m³ and hardness load 16 ± 2 kgf for 25% compression. 3. 3.armrests :the one-piece armrests should be injection moulded from black co-polymer polypropylene. tubular frame: the powder coated (dft 40-60 microns) tubular frame should be cantilever type & made of 0 2.54 ±0.03cm. x 0.2 ±0.016cm.thk. m.s. er.w. tube, as per the Image attached with tender in the Section-IV: Tender Drawings / Images. Original Equipment Manufacturer (OEM) will show the Deisgn Catalogue to the officers of WAPCOS / SAI for finalization of the furniture item. If sample is not as per the satisfaction of officers of WAPCOS/ SAI, then OEM will manufactured as per Design finalised by WAPCOS/ SAI.</p> <p>Note: The design will be as per the Image and no changes will be allowed without the approval of WAPCOS/ SAI. The specification / design of this furniture item will be governed in conjunction with as detailed here in BoQ and Images.</p>	Nos.	1	13218.000	13,218
D	Dining Hall				

SN	Specification of Furniture items	Unit	Qty.	Assessed rate including GST	Amount including GST
15	<p>Manufacturing supply & Installation of 6 seater Dining Table of size 2200 x 900 x 750 mm as per attached drawings. The top of table provided with 18 - 20mm thick Polished granite stone on top with polished & moulded edges made out of two layer of Granite stone 18mm + 18 mm thick as per drawing & image. The Structural Steel used shall be assembled with precise Laser Welding and with good quality Nuts & Bolts with the satisfaction of WAPCOS. The MS Steel used shall be treated by epoxy powder coating and oven baked at temperature above 200 degree Celsius to provide scratch resistant surface coating film of 50-60 micron thickness. 12 mm thick Termite Resistant water ply wood, pre laminated on one side shall be fixed to support the Granite Top. All four legs provided with High Quality Heavy Duty PVC/ Rubber/EPDM Rubber.</p> <p>Note: All the cutting/ bending shall be done by CNC pipe/ tube bending & cutting machine only and finishing by relevant equipped machineries. The Powder coating shall be done thorough fully automated powder coated plant with conveyer facility, baking oven, Powder applicator with 9-11 tank pre treatment mechanism to achieve scratch resistant surface coating film of 50-60 micron thickness. The specification / design of this furniture item will be governed in conjunction with as detailed here in BoQ and Images.</p>	Nos.	18	29945.000	5,39,010
16	<p>Supplying and Installation of Premium Quality Dining Chair of Premium Hybrid Chair with PP seat & SS Legs (SS 202 grade) without Arms, as shown in Images of Room Chair in different colours, as per the colour finalised by the SAI / WAPCOS. The design will be as per the Image OR as finalised by the SAI / WAPCOS during Site Visit. No additional cost due to change of design will be made.</p> <p>The specification / design of this furniture item will be governed in conjunction with as detailed here in BoQ and Images. The options for this items of furniture are also given in the Section-VI of “Tender Drawings / Images”, therefore if client select any one option, then specifications given in the BOQ shall be modified by OEM as per the image selected by client and no additional cost in this regard will be paid to the OEM. Hence OEMs are advised to quote the rate accordingly.</p>	Nos.	108	3823.000	4,12,884
	Total cost of furniture including 18% GST				1,57,66,853