



WAPCOS LIMITED
(A Government of India Undertaking)
Ministry of Jal Shakti
Government of India

e-tender

for

**DRILLING, CONSTRUCTION OF APPROX. 134 NOS. PIEZOMETERS WITH
SUPPLY, INSTALLATION AND COMMISSIONING OF 134 NOS. DIGITAL WATER
LEVEL RECORDER (DWLRS) ALONG WITH SUPPLY, INSTALLATION AND
COMMISSIONING OF 49 NOS. DIGITAL WATER LEVEL RECORDER (DWLRS) IN
EXISTING PIEZOMETERS UNDER GMDA AREA**

Notification No.:

Tender No. WAP/ GWRD&M/ DRILLING-DWLR/2024-25/GMDA/Feb-25/1

(VOLUME-I: TECHNICAL BID)

WAPCOS Limited
9 C, 9th Floor, Hansalaya Building,
Barakhamba Road,
New Delhi,
Delhi-110001

13th February, 2025

WAPCOS LIMITED
(A Government of India Undertaking)
WAPCOS Limited
9 C, 9th Floor, Hansalaya Building, Barakhamba Road, New Delhi, Delhi-110001

NOTICE INVITING e- TENDER (21 Days)

Time Frame For e-Bidding		Date	Time
1	Dates of Online Publication of Tender Documents in CPP portal	13-02-2025	13:00 Hrs.
2	Dates of Tender Document Download	Start	13-02-2025
		End	06-03-2025
3	Date of Pre-Bid Meeting	19-02-2025	11:00Hrs.
4	Dates of Online Submission of Tender	Start	20-02-2025
		End	06-03-2025
5	Time and Date for Opening of Technical Bid	07-03-2025	16:30 Hrs.
6	Deadline for Physical Submission of Tender Fee and EMD	07-03-2025	14:00 Hrs.
7	Time and Date for Opening of Financial Bid	Will be communicated online after Technical evaluation.	

Note: Above Scheduled is Tentative and May be Changed

For and on behalf of WAPCOS Limited, General Manager (GWRDM) invites online item rate tender two bid system (Technical bid and financial bid) at Central Public Procurement Portal (CPPP) at <https://eprocure.gov.in/eprocure/app>, GEM Portal (Notification) and WAPCOS Website <http://www.wapcos.co.in> from approved and eligible, experienced, reputed, technically competent and financially sound registered contractors for the under mentioned work:

Project Name: *“Drilling, construction of approx. 134 nos. piezometers with supply, installation and commissioning of 134 nos. Digital Water Level Recorder (DWLRs) along with supply, installation and commissioning of 49 nos. Digital Water Level Recorder (DWLRs) in Existing Piezometers under GMDA area”.*

Scope of Work: Drilling & Construction of Piezometers with Collection of Litholog, Geophysical logging & interpretation, chemical analysis, construction of platform, installation of display board, installation of MS well cap, clamp, protection box & Submission of Basic Data Reports with supply, installation, testing and commissioning of DWLR (Non-Vented Pressure Type) with Telemetry, including Fencing and Establishment of Data Acquisition System along with its Maintenance for real time Ground Water, its Comprehensive maintenance for 05 Years.

Table – 1

Area	Estimated Amount (INR) (Excluding GST)	EMD (INR)	Time Period (Months)	Tender Fees in INR (including GST)	
GMDA Area	Part-A: Drilling and Construction (5,04,51,522/-) Part-B: DWLRs (Supply, Installation, Commissioning and Maintenance) (2,46,50,000/-)	Total = 7,51,01,522/-	15,02,031/-	9	5900/-

1. A complete set of Tender documents may be downloaded by interested bidders from the <https://etenders.gov.in/eprocure/app> and <http://www.wapcos.gov.in/current-tender-list.aspx> websites. The bidders must pay non-refundable **tender fee**. Tender submission fee: Rs.5,000/- +900 GST=Rs.5,900/- (Bidders shall remit the Tender Fee using the online payment options of eProcurement system only).
2. Bidding will be conducted online competitive bidding procedures two bid system (Technical bid and Financial bid) specified in the Guidelines. The Bidder shall have satisfactory experience and position as stipulated in bidding documents under clause of eligibility and qualification requirements.
3. Interested eligible bidders may obtain further information and inspect the bidding documents at the same address.
4. JV/Consortium is allowed.
5. WAPCOS Ltd. will award contract to the bidder whose bid has been determined to be substantially responsive to the Bidding Documents and who has offered the lowest price.
6. Accepting Authority reserves the right to accept or reject any or all of tender documents without assigning any reason whatsoever.
7. In the event of any of the above mentioned tender opening date being declared as a holiday/ closed day for WAPCOS Ltd., the tenders will be opened on the next working day at the appointed time.
8. Bids shall be received online only at the website of CPP portal <https://etenders.gov.in/eprocure/app>.
9. Aspiring bidders who have not enrolled/ registered in CPP portal are advised to enrol/ register before participating through the portal. The bidders are advised to go through the instructions provided Under ITB clause 1.17 'Instructions for online bid submission'.
10. The bidders will be at liberty to be present either in person or through an authorized representative, who must carry 'Bid Acknowledgement Receipt', at the time of opening of bid or can view the bid opening event online at their remote end.
11. The above particulars may be changed due to Administrative or any other reason and shall be available at CPP Portal and <http://www.wapcos.gov.in/current-tender-list.aspx> website. Therefore, bidders are requested to visit CPP Portal and <http://www.wapcos.gov.in/current-tender-list.aspx> websites frequently for any change above.
12. For any assistance during bid submission, system settings etc. bidders may contact at CPP Portal help desk.

Postal Address/ Physical Address for Tender Fee/ Technical Bid Submission/ EMD Submission:

General Manager (GWRDM)

WAPCOS Limited

**9 C, 9th Floor, Hansalaya Building,
Barakhamba Road,
New Delhi,
Delhi-110001**

General Manager

**(GWRDM)
For WAPCOS Ltd.**

CONTENTS OF TENDER DOCUMENT

CHAPTER NO.	CONTENTS
Chapter-I	Instruction for Bidders
Chapter-II	General Conditions of Contract
Chapter-III	Additional Conditions of Contract
Chapter-IV	Technical Specifications
	Forms
	Annexures

Instruction to Bidders

CHAPTER – I

INSTRUCTION TO BIDDERS

TABLE OF CONTENTS

CLAUSE NO	TITLE OF CLAUSE
1.1	Invitation to Bid
1.2	Eligibility and Qualification Requirements (EQR)
1.3	Cost of Bidding
1.4	Site Visit
1.5	Contents of Bidding Documents
1.6	Clarification of Bidding Documents
1.7	Amendment of Bidding Documents
1.8	Language of Bid
1.9	Documents Comprising the Bid
1.10	Bid Prices
1.11	Currencies of bid and Payment
1.12	Bid Validity Period
1.13	Earnest Money Deposit
1.14	Bidding Condition
1.15	Pre-bid Meeting
1.16	Preparation of Bids
1.17	Instruction for Online Bid submission
1.18	Sealing and Marking of Bids
1.19	Deadline for Submission of Bids
1.20	Modifications and Withdrawal of Bids
1.21	Bid Opening
1.22	Process to be Confidential
1.23	Clarification of Bids
1.24	Determination of Responsiveness
1.25	Correction of Errors
1.26	Evaluation and Comparison of Tender
1.27	Award Criteria
1.28	WAPCOS's Right to Accept any Bid and to Reject any or all Bids
1.29	Notification of Award
1.30	Signing of Agreement
1.31	Performance Security
1.32	Time Period
1.33	Mobilization

CHAPTER – I
INSTRUCTION TO BIDDERS

A. GENERAL

1.1 Invitation to Bid	For and on behalf of WAPCOS Limited, General Manager (GWRDM) invites online item rate tender two bid system (Technical bid and financial bid) from approved, eligible experienced reputed, technically competent and financially sound company/contractor for the work drilling & construction of piezometers & supply, commissioning, installation and maintenance of DWLRs.								
1.1.1 Scope of Work:	<p>Drilling & Construction of Piezometers with Collection of Litholog, Geophysical logging & interpretation, chemical analysis, construction of platform, installation of display board, installation of MS well cap, clamp, protection box & Submission of Basic Data Reports with supply, installation, testing and commissioning of DWLR (Non-Vented Pressure Type) with Telemetry, including Fencing and Establishment of Data Acquisition System along with its Maintenance for real time Ground Water, its Comprehensive maintenance for 05 Years.</p> <p>The detail numbers of wells to constructed are as follows:</p> <p style="text-align: center;">Table – 2</p> <table border="1" data-bbox="416 949 1385 1099"> <thead> <tr> <th>Geology of Area</th> <th>Depth Range of Well*</th> <th>Total Wells</th> <th>Time Period (Months)</th> </tr> </thead> <tbody> <tr> <td>Soft & Hard Rock in GMDA Area</td> <td>60 - 130</td> <td>134</td> <td>9</td> </tr> </tbody> </table> <p>*Based on Depth of Local Water Level</p> <p>Further all materials (ERW MS Blank Pipe/ LCG Screen Pipe/ U - PVC Blank or Slotted) shall be procured from reputed manufacturer in India, as per technical specification & bill of quantities of the Tender Documents.</p> <p>Before inspection of materials contractor/ vendor/ company/ bidder must submit the internal inspection report of the manufacturer & thereafter physical inspection shall be done in the presence of WAPCOS and representative of GMDA, Haryana as per requirement basis. After inspection the Test Certificate with report will be submitted to WAPCOS and only thereafter bidders will supply the materials to the sites.</p> <p>All tools and plant and services including transportation of all men, machinery & material to construction site necessary for accomplishing all the features of the works detailed above shall be provided by the Contractor.</p> <p>All the inspected Materials (Pipes) shall be stored in the store of contractor and will be verified by WAPCOS officers before utilization of those pipes for well assembly construction as Piezometers.</p> <p>DWLRs inspection shall be carried out as per described in technical specification of the Equipments.</p>	Geology of Area	Depth Range of Well*	Total Wells	Time Period (Months)	Soft & Hard Rock in GMDA Area	60 - 130	134	9
Geology of Area	Depth Range of Well*	Total Wells	Time Period (Months)						
Soft & Hard Rock in GMDA Area	60 - 130	134	9						
1.2 Eligibility and Qualification Requirements (EQR)	<p>This invitation to bid is open to any bidder meeting the following requirements :</p> <p>The bidder shall be qualified for the contract as notified by the Employer in subsequent clauses.</p> <p>1.2.1 Any tenderer, (proprietorship firms, partnerships firms, companies, corporations, joint ventures) registered with Central or State Government or the Central Ground Water Authority (CGWA) are eligible to participate in the tender. A self attested copy in respect of valid registration/ enlistment with the respective authorities is to be</p>								

submitted

1.2.2 Bidders are permitted to form consortium/Joint Venture. The clauses as given below shall be applicable for consortium /Joint Venture.

- i In case of a consortium /Joint Venture, certified copy of the agreement between various partners shall be submitted with the tender.
- ii The consortium /Joint Venture shall nominate a Representative who shall have the authority to conduct all business for and on behalf of any and all the members of the JV during the bidding process and, in the event the JV is awarded the Contract, during contract execution.
- iii The consortium /Joint Venture will identify a lead partner who will be authorised to execute the contract with the department. All financial transactions and liabilities shall rest with the lead partner.
- iv JV members are jointly and severally responsible and liable for the contract. For pre- qualification, the JV should fulfil the criteria specified in the pre-qualification document. The attributes to be evaluated will be the same as for individual contractors; however, certain parameters up to the specified limits have to be essentially met by them collectively, some by the lead partner, and some by the other partner, as briefly described below:

X. Qualifying factors to be met collectively:

- (A) Annual turnover from construction;
- (B) Nos. of Well construction experience

Y. Qualifying factors for lead partner:

- (A) Nos. of Well construction experience

Not less than of 50 (fifty) percent of the respective limits of above criteria prescribed in case of individual contractors may be accepted;

Z. Qualifying factors for other partner:

Same as for lead partner except that for the factors specified in (Y) above, a lower limit of 25 (twenty-five) per cent.

- v A tenderer shall submit only one bid in the same tendering process, either individually as a tenderer or as a partner of a consortium /Joint Venture.
- vi Number of the members/firms in a joint venture shall not be more than two including the lead partner.

1.2.3 A Bidder shall not have a conflict of interest. Any Bidder found to have a conflict of interest shall be disqualified. A Bidder may be considered to have a conflict of interest for the purpose of this bidding process, if the Bidder:

- i directly or indirectly controls, is controlled by or is under common control with another Bidder or
- ii receives or has received any direct or indirect subsidy from any other Bidder; or
- iii has the same legal representative as another Bidder; or
- iv has a relationship with another Bidder, directly or through common third parties, that puts it in a position to influence the bid of another Bidder, or influence the decisions of the Purchaser regarding this bidding process; or
- v participates in more than one bid in this bidding process. Participation

by a Bidder in more than one Bid will result in the disqualification of all Bids in which such Bidder is involved.

1.2.4 All the Bidder should specify the their DWLR Original Equipment Manufacture (OEM)/Authorized Suppliers (Number of such DWLR OEM/authorized Suppliers should not more than 1) and give an undertaking that they will supply DWLR from those reputed DWLR OEM/Authorized Suppliers only and clearly mentioning the numbers of DWLR to be supplied by OEM/authorized Suppliers as per specifications of DWLRs mentioned in the Tender Document.

1.2.5 Bidders will be required to employ at ground water professional with minimum qualification of graduate degree in engineering/master's degree in geosciences with minimum 3 years of experience in construction of exploratory & observation, Piezometer wells and similar works. The undertaking for employment of these ground water professional be given.

The bidder must ensure to deploy required equipment as proposed in the format within the mobilization period till the completion of the project, otherwise WAPCOS shall be free to terminate the work due to non-mobilization of equipment as committed in the tender without any notice. In case bidder submit details of machinery hired or taken on lease, then bidder shall obtain affidavits on stamp paper verified by notary from owner of the machinery and shall submit the same along with the bid. Ownership record of the machinery such as copy of registration certificate, purchase memo etc. shall also be submitted.

Details required for Equipments and Manpower are as under:

Table – 2

Equipments/ Machineries (own)	No.	Manpower (Regular/ Contract)	No.
Drilling Rigs:	5	Geologist	3
Air Compressor:	1	Geophysicist (Analysis Basis)	1
Geophysical Logger:	1	Project Engineer For DWLR	1

(Note: Minimum Man power and Machinery as stated above should be arranged by the bidder separately and bidder can deploy manpower and machineries as per site requirement).

The bidder must submit details of equipments as per **Form B** along with documentary proof. If bidder failed to deploy equipments/machineries within mobilisation period as mentioned in the tender documents, WAPCOS is free to terminate the contract at any time & forfeit the Bank Guarantee and blacklist the bidder.

Bidder has to submit an undertaking to deploy the above machineries for which he participated in the bidding process.

1.2.6 Bidder will be required to deploy atleast one dedicated Service Engineer/ Project Engineer for DWLR cum operator at the Regional office Data Center for Operation of DWLR system and ensure seamless data transfer from remote DWLR stations to National Data Center through GSM/GPRS

network & then to India WRIS/WIMS software through internet. The processed data from India WRIS/ WIMS in the form of reports/ bulletins will be transmitted to Regional & National Data Centre as per technical specifications. The undertaking for employment of these ground water professional be given.

1.2.7 Bidders will be required to deploy at least 5 rigs for the package along with submersible pumps of various capacities, ancillaries equipments tools accessories required for construction of well and over pumping as mentioned in the Annexure V, Scope of Work and Technical specification. An undertaking in this regard should be submitted in the technical Bid.

1.2.8 Bid Capacity The bidder should possess the bidding capacity as calculated by the specified formula. The formula generally used is: Available bid capacity = $A \times 1.5 \times N - B$,

where A = Maximum value of engineering (Civil/ Electrical/ Mechanical as relevant to work being procured) works executed in any one year during the last five years (updated at the current price level), taking into account the completed as well as works in progress.

N = Number of years prescribed for completion of the work in question.
B = Value (updated at the current price level) of the existing commitments and ongoing works to be completed in the next 'N' years.

1.2.9 Average annual financial turnover during the last three years, ending 31st March 2024 of the previous financial year should be at least 50% of the estimated cost. (Balance Sheet duly audited and certified by Chartered Accountant) Note: In case of last financial year Bidder may submit the Provisional Balance Sheet duly signed by CA.

1.2.10 The bidder should have experience of having successfully completed similar works during last 7 years ending last day of month previous to the one in which tenders are invited:

(a) Three similar completed works costing not less than the amount equal to 40% of the (estimated cost of PART-A of the Tender i.e for construction PZ part if similar work is Type-1 nature) or (estimated cost of PART-B of the Tender i.e for the DWLR part if similar work is Type-2 nature)

or

Two similar completed works costing not less than the amount equal to 50% of (estimated cost of PART-A of the Tender i.e for construction PZ part if similar work is Type-1 nature) or (estimated cost of PART-B of the Tender i.e for the DWLR part if similar work is Type-2 nature)

or

One similar completed work costing not less than the amount equal to 80% of the (estimated cost of PART-A of the Tender i.e for construction PZ part if similar work is Type-1 nature) or (estimated cost of PART-B of

the Tender i.e for the DWLR part if similar work is Type-2 nature)

(b) Definition of Similar works:

Types of Similar works are defined as:

Type-1: Any work in which drilling for exploration/exploitation of natural resources is component of scope of work

Type-2: Supply/Installation/commissioning/Maintenance of Digital Water Level Recorder.

(c) The value of the executed work shall be brought to the current costing level by enhancing the actual value of works at simple rate of 7% per annum calculated from the date of completion to last date of submission of bid.

(d) The tenderer shall submit details of works executed by them in last 7 years for qualification of work experiences criteria, documentary proof such as completion certificate & other documents from client clearly indicating the nature/scope of work, contract number, contract amount and actual date of completion, of such works. Rig deployment /copy of work order cannot be considered as work completion. Work completion certificate or part completion certificate is to be submitted.

(e) In case the work is done for private/ Government clients, details as per Form at Sl.No.C-(a) & C-(b) of Form C are to be submitted. Documents are to be submitted. Documents establishing receipt of payment for such works are to be submitted. For this purpose, TDS certificate or Form 26 AS of Income Tax department or copy of Bank statement or any other document clearly indicating name of organisation making payment, amount of payment shall be submitted.

(f) The tenderer or their DWLR OEM/authorized Suppliers as specified in ITB Clause 1.2.4 should have supplied and commissioned at least 10 % of the Digital Water Level Recorders stations with GSM / GPRS based telemetry during previous 7 (Seven) Financial years to Central Government/ State Government Departments or Public Sector Undertakings or any Project/ any other Public/ Private Customers in India. Note: The proof of supply as per supply order along with Commissioning/ Installation / Performance report/certificate in respect of successful commissioning.

(g) The bidder should have after sales support in the region (within a radius of 500 km from the State Capital) for Digital Water Level Recorders stations with GSM / GPRS based telemetry. If bidder does not have any after sales support office within 500 km from state Capital at the time of bidding, he shall be required to establish the same within one month after successful award of contract.

(h) The bidder shall submit the product brochure/literature, compliance statement duly signed by the bidder and other supporting document if any to establish the claim that the offered equipment meets the technical specifications provided in tender document. If there is any deviation in specification it should be mentioned in separate column of compliance statement.

1.2.11 The bidder must submit an undertaking for carrying out chemical analysis of water samples from any NABL accredited lab/labs. The Lab/labs shall have combined capacity of analyzing at least 300 water

	<p>samples in a month.</p> <p>1.2.12 Well construction Experience</p> <p>“They must have drilled/completed wells to a depth of at least 75 m. Number of such wells should not be less than 10% of number of wells to be constructed in the Tender during previous 7 (Seven) Financial years for Central Government/ State Government Departments or Public Sector Undertakings or any Project/ any other Public/ Private Customers in India.”</p> <p>1.2.13 a.) Bidder should have registered for GST (provide GSTIN certificate).</p> <p>b.) The bidder should be register in the state for GST in which the work is to be taken up and shall submit the GST registration certificate. If the bidder has not obtained the GST registration in the state in which the work is to be taken up or as required by GST authorities then in such case the bidder shall scan and upload following undertaking along with bid document.</p> <p>“If the work is awarded to me, I/We shall obtain GST registration certificate of the state in which work is to be taken up within one month from the date of receipt of award letter or before release of any payment by WAPCOS Ltd., whichever is earlier, falling which I/ We shall be responsible for delay in payment which will be due towards me /us on account of work executed and/ or for any action taken by WAPCOS or GST Department in this regard.</p> <p>1.2.14 The bidder should not have incurred any loss (profit after tax should be positive) in more than two year during available last five consecutive balance sheets, duly certified and audited by the chartered accountant. Yearly Turnover and audited balance sheet for last 5 years ending the financial year 2023-24 duly certified by chartered accountant should be submitted. Any such certificate must carry the UDIN (Unique document identification number).</p> <p>1.2.15 Bidder must not be black listed or debarred by any Government organization. Bidder should disclose their litigation history, if any. Both documents should be supported with an affidavit duly certified by notary.</p> <p>1.2.16 Bidder should have a solvency equal to 40% of estimated cost. The bidder must submitted original Solvency certificate to WAPCOS office before due date. Bidder must provide the name, designation, power of attorney with valid official email id and contact number of issuing Bank Authority of solvency certificate. Solvency Certificate must have been issued after the date of publication of NIT & be addressed to the tendering authority quoting the name of the work. The Solvency Certificate should not be dated beyond the last date of submission of the bids.</p>
<p>1.3 Cost of Bidding</p>	<p>The bidder shall bear all costs associated with preparation and submission of his bid and WAPCOS shall in no case be responsible or liable for these costs, regardless of the conduct or outcome of the bidding process.</p>

1.4 Site Visit	The Bidder, at the bidder's own responsibility and risk is encouraged to visit and examine the site of works and its surroundings and obtain all information that may be necessary for preparing the bid and entering into a contract for construction of the works. The cost of visiting the site shall be at the bidder's own expense.
-----------------------	--

B. THE BIDDING DOCUMENTS

1.5 Contents of Bidding Documents	<p>1.5.1 The bidding documents together with any addenda thereto, issued in accordance with Para 1.7 and any Minutes of pre-bid Meeting issued in accordance with Para 1.15 will include the following:</p> <p style="text-align: center;">Volume-I:</p> <p style="text-align: center;">Technical Bid</p> <p style="text-align: center;">S.No.Chapter Contents</p> <p style="text-align: center;">1 Instruction to Bidders (ITB) 2 General Condition of Contract (GCC) 3 Additional Condition of Contract (ACC) 4 Technical Specifications (TS)</p> <table border="0" style="width: 100%;"> <thead> <tr> <th style="text-align: left;">Form</th> <th style="text-align: left;">Contents</th> </tr> </thead> <tbody> <tr> <td>Form-A</td> <td>Financial Strength (Sub-Form A1 (Turn over) & A2 (Solvency certificate))</td> </tr> <tr> <td>Form-B</td> <td>Personnel and Equipments (Sub-Form B1, B2& B3)</td> </tr> <tr> <td>Form – C</td> <td>Format for Exploratory wells/ Deep Tubewell Works Presently under Construction</td> </tr> </tbody> </table> <table border="0" style="width: 100%;"> <thead> <tr> <th style="text-align: left;">Schedule</th> <th style="text-align: left;">Details</th> </tr> </thead> <tbody> <tr> <td>Schedule No. 1</td> <td>Schedule of tests</td> </tr> <tr> <td>Schedule No. 2</td> <td>Schedule of maintenance and erection tools & tackles</td> </tr> <tr> <td>Schedule No. 3</td> <td>Additional information included with the proposal.</td> </tr> <tr> <td>Schedule No. 4</td> <td>Schedule of Weights & Dimensions</td> </tr> <tr> <td>Schedule No. 5</td> <td>Schedule of Submission of Drawings/ Documents</td> </tr> <tr> <td>Schedule No. 6</td> <td>Performance Gurantee</td> </tr> </tbody> </table> <p>Annexures:</p> <table border="0" style="width: 100%;"> <tr> <td>Annex-I</td> <td>Proforma for bank guarantee for Earnest Money Deposit</td> </tr> <tr> <td>Annex-II</td> <td>Proforma for Bid (To be enclosed with Price Bid)</td> </tr> <tr> <td>Annex-III</td> <td>Proforma of Agreement</td> </tr> <tr> <td>Annex-IV</td> <td>Proforma for Bank Guarantee for Performance Security</td> </tr> <tr> <td>Annex-V</td> <td>Proforma for Bank Guarantee for Advance for Mobilization</td> </tr> <tr> <td>Annex – VI</td> <td>Tender Form</td> </tr> <tr> <td>Annex – VII</td> <td>Manufacturer's Authorisation Form</td> </tr> <tr> <td>Annexure – VIII</td> <td>Undertaking for non Corrupt/ Fraudulent Practices</td> </tr> <tr> <td>Annexure – IX</td> <td>Litigation History</td> </tr> <tr> <td>Annexure – X</td> <td>Integrity Pact</td> </tr> <tr> <td>Annexure – XI</td> <td>Checklist</td> </tr> <tr> <td>Annex-IX</td> <td>Undertaking Regarding Blacklisting/Non-Debarment</td> </tr> </table> <p style="text-align: center;">Volume-II: Price Bid (Bill of quantities)</p>	Form	Contents	Form-A	Financial Strength (Sub-Form A1 (Turn over) & A2 (Solvency certificate))	Form-B	Personnel and Equipments (Sub-Form B1, B2& B3)	Form – C	Format for Exploratory wells/ Deep Tubewell Works Presently under Construction	Schedule	Details	Schedule No. 1	Schedule of tests	Schedule No. 2	Schedule of maintenance and erection tools & tackles	Schedule No. 3	Additional information included with the proposal.	Schedule No. 4	Schedule of Weights & Dimensions	Schedule No. 5	Schedule of Submission of Drawings/ Documents	Schedule No. 6	Performance Gurantee	Annex-I	Proforma for bank guarantee for Earnest Money Deposit	Annex-II	Proforma for Bid (To be enclosed with Price Bid)	Annex-III	Proforma of Agreement	Annex-IV	Proforma for Bank Guarantee for Performance Security	Annex-V	Proforma for Bank Guarantee for Advance for Mobilization	Annex – VI	Tender Form	Annex – VII	Manufacturer's Authorisation Form	Annexure – VIII	Undertaking for non Corrupt/ Fraudulent Practices	Annexure – IX	Litigation History	Annexure – X	Integrity Pact	Annexure – XI	Checklist	Annex-IX	Undertaking Regarding Blacklisting/Non-Debarment
Form	Contents																																														
Form-A	Financial Strength (Sub-Form A1 (Turn over) & A2 (Solvency certificate))																																														
Form-B	Personnel and Equipments (Sub-Form B1, B2& B3)																																														
Form – C	Format for Exploratory wells/ Deep Tubewell Works Presently under Construction																																														
Schedule	Details																																														
Schedule No. 1	Schedule of tests																																														
Schedule No. 2	Schedule of maintenance and erection tools & tackles																																														
Schedule No. 3	Additional information included with the proposal.																																														
Schedule No. 4	Schedule of Weights & Dimensions																																														
Schedule No. 5	Schedule of Submission of Drawings/ Documents																																														
Schedule No. 6	Performance Gurantee																																														
Annex-I	Proforma for bank guarantee for Earnest Money Deposit																																														
Annex-II	Proforma for Bid (To be enclosed with Price Bid)																																														
Annex-III	Proforma of Agreement																																														
Annex-IV	Proforma for Bank Guarantee for Performance Security																																														
Annex-V	Proforma for Bank Guarantee for Advance for Mobilization																																														
Annex – VI	Tender Form																																														
Annex – VII	Manufacturer's Authorisation Form																																														
Annexure – VIII	Undertaking for non Corrupt/ Fraudulent Practices																																														
Annexure – IX	Litigation History																																														
Annexure – X	Integrity Pact																																														
Annexure – XI	Checklist																																														
Annex-IX	Undertaking Regarding Blacklisting/Non-Debarment																																														

	<p>1.5.2 The bidder is expected to examine carefully all instructions, conditions, proforma, terms & specifications and drawings in the Bidding Documents. Failure to comply with the requirement of bid submission will be at the bidder's own risk.</p> <p>Pursuant to Para 1.24, bids which are not substantially responsive to the requirements of the bidding document will be rejected.</p>
1.6 Clarification of Bidding Documents and Pre-Bid Meeting	<p>A prospective bidder requiring any clarification of the Bidding Documents may notify in writing to the General Manager (GWRDM), WAPCOS, who will respond in writing/through email to any request for clarification which he receives earlier than the time schedule mentioned in NIET.</p>
1.7 Amendment of Bidding Documents	<p>1.7.1 At any time prior to the deadline for submission of bids, WAPCOS may, for any reason, whether at its own initiative or in response to a clarification requested by a prospective bidder, modify the Bidding Documents by the issuance of an Addendum.</p> <p>1.7.2 The corrigendum if any will be uploaded on CPP portal.</p> <p>1.7.3 In order to afford prospective bidders reasonable time in which to take an corrigendum into account in preparing their bids, WAPCOS may, at its discretion, extend the deadline for the submission of bids in accordance with Para 1.19. A minimum period of 5 days will be provided to enable bidders to assess the implications of the corrigendum.</p>
C. PREPARATION OF BIDS	
1.8 Language of Bid	<p>The bid prepared by the bidder and all correspondence and documents relating to the bid exchanged by the bidder and WAPCOS shall be written in the English language.</p>

**1.9
Documents
Comprising
the Bid**

The bid to be prepared by the bidder shall be on two bid system (Technical bid and financial bid) basis and shall comprise of the following:

1. Technical Bid (Marked as Volume-1 on CPP Portal)

- i. Scan copy of completed tender documents with required Certificates, Forms and Annexures used thereto duly filled in and signed wherever required without altering the formats.
- ii. Scanned copy of tender fee in shape of Demand draft from any scheduled bank in favour of WAPCOS Ltd., payable at New Delhi.
- iii. Scanned copy of Earnest Money Deposit either in the Demand Draft or Bank Guarantee as per Annexure – 1.

NOTE: The original payment instrument like EMD, copy slip of tender fee payment, as specified in this tender document has to be sent to the address **To: WAPCOS Limited, 9 C, 9th Floor, Hansalaya Building, Barakhamba Road, New Delhi-110001**; by post/speed post/courier/by hand on or before the due date & time of opening online bids. Otherwise the tender will be summarily rejected without assigning any reason.

2. Financial Bid (marked as Volume-2 on CPP Portal).

- i. Bill of Quantities with rates filled in figures and correctly calculated amount, in appropriate columns.

NOTE: **1.** Volume-2 will be opened only after satisfying that the bidder meets the eligibility requirements after technical evaluation. Any lapse in providing documentary evidence towards meeting the eligibility requirement may lead to non-opening of Volume -2 of the bidder and thus rejection of his/ her bid.

- 2.** Unit rate/ Item rate quoted under financial bid should not be abnormal.

The sequence/ order of the documents should be followed as per checklist enclosed **(Annexure – XI)** in the tender document.

<p>1.10 Bid Price</p>	<p>1.10.1 The contract shall be for whole work based on the unit rates/ prices submitted by the bidder.</p> <p>1.10.2 The bidder shall fill in rates and prices for all items of Works described in the Bill of Quantities including all duties, levies etc. (except GST). GST amount will be reimbursed as per Government of India prevailing rate.</p> <p>1.10.3 Any bid, which proposes any alteration in the work specified in the said form of bidding document, or in the time allowed for carrying out the work or which contains any other conditions of any sort including conditional rebates, will be summarily rejected.</p> <p>1.10.4 In event no rate has been quoted for any item (s), leaving space both in figure (s), word (s) and amount blank, it will be presumed that the contractor has included the cost of this/ these item (s) in other items and rate for such item (s) will be considered as zero and work will be required to be executed accordingly.</p> <p>1.10.5 In respect of GST, same shall be paid by the contractor to the concerned department and it will be reimbursed to him by Engineer – in- charge after satisfying that it has been actually and genuinely paid by the contractor only if contractor submit proof of payment of GST within 15 Days of Payment. The contractor shall furnish return on GST portal from time to time and WAPCOS will have the right to withhold the payment if GST returns are not covering the bill raised to WAPCOS.</p>
<p>1.11 Currencies of bid and Payment</p>	<p>1.11.1 The unit rates and prices shall be quoted by the bidder entirely in Indian Rupees only.</p>
<p>1.12 Bid Validity Period</p>	<p>1.12.1 Bids shall remain valid for acceptance for a period of 120 days (one hundred twenty days) from the date of opening of bids prescribed in Para 1.21 hereof.</p> <p>1.12.2 In exceptional circumstances, prior to expiry of the original bid validity period, WAPCOS may request the bidder for a specified extension in the period of validity. A bidder agreeing to the request will be required to extend the validity of his Earnest Money Deposit correspondingly. The provisions of Para 1.13 regarding discharge and forfeiture of Earnest Money Deposit shall continue to apply during the extended period of bid validity.</p>

<p>1.13 Earnest Money Deposit</p>	<p>1.13.1 The bidder shall furnish, as part of his bid, an earnest money deposit for an amount as listed in Table-I of tender document.</p> <p>1.13.2 The Earnest Money Deposit shall at the bidder's option be in any one of the following alternative forms: (a) Crossed bank draft or fixed deposit receipt from any e in favour WAPCOS Limited payable at New Delhi. (b) Irrevocable bank guarantee issued by any scheduled bank in India, and pledged in favour of WAPCOS Ltd. The Proforma for the bank guarantee shall be in accordance with Annexure-I.</p> <p>1.13.3 The earnest money deposit shall be made payable to WAPCOS Ltd. without any condition (s) or reservations in respect of bank drafts. Earnest money deposit shall remain valid for 60 days beyond the period of validity of the bid.</p> <p>1.13.4 a. The bid can only be submitted after deposition of EMD in favour of WAPCOS Ltd. in the form prescribed in tender documents and upload the mandatory scanned documents such as receipt for deposition of EMD and other documents specified. b. Any bid not accompanied by an acceptable earnest money deposit will be rejected by WAPCOS as non-responsive.</p> <p>1.13.5 The Earnest Money Deposit of unsuccessful bidders will be discharged /returned as promptly as possible, but not later than sixty days after expiration of the period of bid validity prescribed by WAPCOS. The Earnest money will be returned to the bidder without any interest if his bid is not accepted without any interest.</p> <p>1.13.6 The Earnest Money Deposit of the successful bidder will be discharged when the bidder has signed the agreement and furnished the required performance security.</p> <p>1.13.7 No interest shall be paid by WAPCOS on the Earnest Money Deposit.</p> <p>1.13.8 The Earnest Money Deposit may be forfeited; (i) If a bidder withdraws his bid during the period of bid validity (ii) In case of successful bidder, if he fails within the specified time limit to: - sign the Agreement, or furnish the required performance security</p>
<p>1.14 Bidding Condition</p>	<p>The bidder shall submit offers which comply fully with the requirements of the Bidding Documents.</p>
<p>Pre-1.15 Pre-Bid Meeting</p>	<p>1.15.1 A pre-bid meeting, open to all prospective bidders who have purchased the Bidding documents is contemplated to be convened in WAPCOS office at WAPCOS Limited, 9 C, 9th Floor, Hansalaya Building, Barakhamba Road, New Delhi-110001 on 19.02.2025 at 11:00 hrs in the committee room of WAPCOS. Any change in the time and date of the pre-bid meeting shall be notified to the bidders 2 (two) days in advance.</p> <p>1.15.2 The purpose of this meeting will be to issue clarifications and to answer queries on any matter that may be raised on the bidding document.</p> <p>1.15.3 The bidder is requested to submit queries, in writing/ e-mail gwrmdm@wapcos.co.in to reach the office of the WAPCOS Limited, 9 C, 9th Floor, Hansalaya Building, Barakhamba Road, New Delhi-110001 not later than 3 (three) days before the meeting.</p>
<p>1.16 Preparation of Bids</p>	<p>1.16.1 Bidder should take into account any corrigendum/ addendum published on the tender document before submitting their bids.</p> <p>1.16.2 Please go through the tender advertisement and the tender document carefully to understand the documents required to be submitted as part of</p>

the bid. Please note the number of covers in which the bid documents have to be submitted, the number of documents - including the names and content of each of the document that need to be submitted. Any deviations from these may lead to rejection of the bid.

SUBMISSION OF BIDS

1.17 Instruction for Online Bid Submission

1. Bids must be received by the Employer at the address specified under ITB Sub-Clause no later than the time and date stated in the BDS.
2. The Employer may, at its discretion, extend this deadline for submission of bids by amending the bidding documents in accordance with ITB Sub-Clause in which case all rights and obligations of Employer and bidders will thereafter be subject to the deadline as extended.
3. In cases where the manufacturer has submitted the bid, the bids of its authorized dealer will not be considered and EMD will be returned.
4. The bidders are required to submit soft copies of their bids electronically on the CPP Portal, using valid Digital Signature Certificates. The instructions given below are meant to assist the bidders in registering on the CPP Portal, prepare their bids in accordance with the requirements and submitting their bids online on the CPP Portal.
5. Use Internet Explorer to go to <https://etenders.gov.in/eprocure/app?page=Home&service=page>

INSTRUCTIONS FOR ONLINE SUBMISSION OF BIDS

6. The bidders are required to submit soft copies of their bids electronically on the CPP Portal, using valid Digital Signature Certificates. The instructions given below are meant to assist the bidders in registering on the CPP Portal, prepare their bids in accordance with the requirements and submitting their bids online on the CPP Portal.
7. More information useful for submitting online bids on the CPP Portal may be obtained at: <https://etenders.gov.in/eprocure/app?page=Home&service=page>

REGISTRATION

8. Bidders are required to enroll on the e-Procurement module of the Central Public Procurement Portal (URL: <https://eprocure.gov.in/eprocure/app>) by clicking on the link "Online bidder Enrollment" on the CPP Portal which is free of charge.
9. As part of the enrolment process, the bidders will be required to choose a unique username and assign a password for their accounts.
10. Bidders are advised to register their valid email address and mobile numbers as part of the registration process. These would be used for any communication from the CPP Portal.
11. Upon enrolment, the bidders will be required to register their valid Digital Signature Certificate (Class II or Class III Certificates with signing key usage) issued by any Certifying Authority recognized by CCA India (e.g. Sify / TCS / nCode / eMudhra etc.), with their profile.
12. Only one valid DSC should be registered by a bidder. Please note that the bidders are responsible to ensure that they do not lend their DSC's to others which may lead to misuse.
13. Bidder then logs in to the site through the secured log-in by entering their user ID / password and the password of the DSC / e-Token.

SEARCHING FOR TENDER DOCUMENTS

14. There are various search options built in the CPP Portal, to facilitate bidders

to search active tenders by several parameters. These parameters could include Tender ID, Organization Name, Location, Date, Value, etc. There is also an option of advanced search for tenders, wherein the bidders may combine a number of search parameters such as Organization Name, Form of Contract, Location, Date, Other keywords etc. to search for a tender published on the CPP Portal.

15. Once the bidders have selected the tenders they are interested in, they may download the required documents / tender schedules. These tenders can be moved to the respective 'My Tenders' folder. This would enable the CPP Portal to intimate the bidders through SMS / e-mail in case there is any corrigendum issued to the tender document.
16. The bidder should make a note of the unique Tender ID assigned to each tender, in case they want to obtain any clarification / help from the Helpdesk.

PREPARATION OF BIDS

17. Bidder should take into account any corrigendum published on the tender document before submitting their bids.
18. Please go through the tender advertisement and the tender document carefully to understand the documents required to be submitted as part of the bid. Please note the number of covers in which the bid documents have to be submitted, the number of documents - including the names and content of each of the document that need to be submitted. Any deviations from these may lead to rejection of the bid.
19. Bidder, in advance, should get ready the bid documents to be submitted as indicated in the tender document / schedule and generally, they can be in PDF / XLS / RAR / DWF/JPG formats. Bid documents may be scanned with 100 dpi with black and white option which helps in reducing size of the scanned document.
20. To avoid the time and effort required in uploading the same set of standard documents which are required to be submitted as a part of every bid, a provision of uploading such standard documents (e.g. PAN card copy, annual reports, auditor certificates etc.) has been provided to the bidders. Bidders can use "My Space" or "Other Important Documents" area available to them to upload such documents. These documents may be directly submitted from the "My Space" area while submitting a bid, and need not be uploaded again and again. This will lead to a reduction in the time required for bid submission process.

SUBMISSION OF BIDS

21. Bidder should log into the site well in advance for bid submission so that they can upload the bid in time i.e. on or before the bid submission time. Bidder will be responsible for any delay due to other issues.
22. The bidder has to digitally sign and upload the required bid documents one by one as indicated in the tender document.
23. Bidder has to select the payment option as "offline" to pay the tender fee / EMD as applicable and enter details of the instrument.
24. Bidder should prepare the EMD as per the instructions specified in the tender document. The original should be posted/couriered /given in person to the concerned official, latest by the last date of bid submission or as specified in the tender documents. The details of the DD/any other accepted instrument, physically sent, should tally with the details available in the scanned copy and the data entered during bid submission time. Otherwise the uploaded bid will be rejected.
25. Bidders are requested to note that they should necessarily submit their financial bids in the format provided and no other format is acceptable. If the price bid has been given as a standard BoQ format with the tender

	<p>document, then the same is to be downloaded and to be filled by all the bidders. Bidders are required to download the BoQ file, open it and complete the white colored (unprotected) cells with their respective financial quotes and other details (such as name of the bidder). No other cells should be changed. Once the details have been completed, the bidder should save it and submit it online, without changing the filename. If the BoQ file is found to be modified by the bidder, the bid will be rejected.</p> <p>26. The server time (which is displayed on the bidders' dashboard) will be considered as the standard time for referencing the deadlines for submission of the bids by the bidders, opening of bids etc. The bidders should follow this time during bid submission.</p> <p>27. All the documents being submitted by the bidders would be encrypted using PKI encryption techniques to ensure the secrecy of the data. The data entered cannot be viewed by unauthorized persons until the time of bid opening. The confidentiality of the bids is maintained using the secured Socket Layer 128 bit encryption technology. Data storage encryption of sensitive fields is done. Any bid document that is uploaded to the server is subjected to symmetric encryption using a system generated symmetric key. Further this key is subjected to asymmetric encryption using buyers/bid opener's public keys. Overall, the uploaded tender documents become readable only after the tender opening by the authorized bid openers.</p> <p>28. The uploaded tender documents become readable only after the tender opening by the authorized bid openers.</p> <p>29. Upon the successful and timely submission of bids (i.e. after Clicking "Freeze Bid Submission" in the portal), the portal will give a successful bid submission message and a bid summary will be displayed with the bid no. and the date and time of submission of the bid with all other relevant details.</p> <p>30. The bid summary has to be printed and kept as an acknowledgement of the submission of the bid. This acknowledgement may be used as an entry pass for any bid opening meetings.</p> <p style="text-align: center;"><u>ASSISTANCE TO BIDDERS</u></p> <p>31. Any queries relating to the tender document and the terms and conditions contained therein should be addressed to the Tender Inviting Authority or the relevant contact person indicated in the tender.</p> <p>32. Any queries relating to the process of online bid submission or queries relating to CPP Portal in general may be directed to the 24x7 CPP Portal Helpdesk. The contact numbers for the 24 X 7 helpdesk are 0120-4001 002/ 0120-4001 005 Email Support: Technical - support-eproc(at)nic(dot)in Policy Related - cppp-doe(at)nic(dot)in</p>
<p>1.18 Sealing and Marking of Bids</p>	<p>1 Bidder should log into the site well in advance for bid submission so that they can upload the bid in time i.e. on or before the bid submission time. Bidder will be responsible for any delay due to other issues.</p> <p>2 The bidder has to digitally sign and upload the required bid documents one by one as indicated in the tender document.</p> <p>3 Bidder has to select the payment option as "offline" to pay the tender fee / EMD as applicable and enter details of the instrument.</p> <p>4 Bidder should prepare the EMD as per the instructions specified in the tender document. The original should be posted/couriered/given in person to the concerned official, latest by the last date & time of bid submission or as specified in the tender documents. The details of the DD/any other accepted instrument, physically sent, should tally with the details available in the scanned copy and the data entered during bid submission time. Otherwise the</p>

	<p>uploaded bid will be rejected.</p> <p>5 Bidders are requested to note that they should necessarily submit their financial bids in the format provided and no other format is acceptable. If the Financial Bid has been given as a standard BoQ format with the tender document, then the same is to be downloaded and to be filled by all the bidders. Bidders are required to download the BoQ file, open it and complete the white coloured (unprotected) cells with their respective financial quotes and other details (such as name of the bidder). No other cells should be changed. Once the details have been completed, the bidder should save it and submit it online, without changing the filename. If the BoQ file is found to be modified by the bidder, the bid will be rejected.</p> <p>6 The server time (which is displayed on the bidders' dashboard) will be considered as the standard time for referencing the deadlines for submission of the bids by the bidders, opening of bids etc. The bidders should follow this time during bid submission.</p> <p>7 All the documents being submitted by the bidders would be encrypted using PKI encryption techniques to ensure the secrecy of the data. The data entered cannot be viewed by unauthorized persons until the time of bid opening. The confidentiality of the bids is maintained using the secured Socket Layer 128 bit encryption technology. Data storage encryption of sensitive fields is done. Any bid document that is uploaded to the server is subjected to symmetric encryption using a system generated symmetric key. Further this key is subjected to asymmetric encryption using buyers/bid opener's public keys. Overall, the uploaded tender documents become readable only after the tender opening by the authorized bid openers.</p> <p>8 The uploaded tender documents become readable only after the tender opening by the authorized bid openers.</p> <p>9 Upon the successful and timely submission of bids (i.e. after Clicking "Freeze Bid Submission" in the portal), the portal will give a successful bid submission message & a bid summary will be displayed with the bid no. and the date & time of submission of the bid with all other relevant details.</p> <p>10 The bid summary has to be printed and kept as an acknowledgement of the submission of the bid. This acknowledgement may be used as an entry pass for any bid opening meetings.</p> <p>11 The Bidder should submit Original copies of Tender Fee & EMD/Bank Guarantee put in one envelope, before the due date & Time of opening online Bids or as indicted in the tender documents.</p> <p>12 Any queries relating to the tender document and the terms and conditions contained therein should be addressed to the Tender Inviting Authority or the relevant contact person indicated in the tender.</p> <p>13 Any queries relating to the process of online bid submission or queries relating to CPP Portal. Portal in general may be directed to the 24x7 Helpdesk. The contact number for the helpdesk is 0120-4001 002/0120-4001 005</p> <p>14 The scanned copies of following documents must be submitted with the online bid in two volumes:</p> <p>The Volume-1 should contain documents as per Checklist (Annexure – XI)</p> <p>The Volume-2 should contain Price Bid/ BOQ</p> <p>The bidders should put serial numbers on all the pages as per checklist (Annexure – XI) before uploading on the portal.</p>
1.19 Deadline for	1.19.1 The e-bids must be submitted, not later than 1630 Hrs on 06.03.2025.

Submission of e-Bids	1.19.2 WAPCOS may, at its discretion, extend the deadline for submission of bids by issuing an amendment in accordance with Para 1.7 in which case all rights and obligations of WAPCOS and the bidder previously subject to the original deadline shall thereafter be subject to the new deadline as extended.
1.20 Modifications and Withdrawal of Bids	1.20.1 The bidder may modify or withdraw his submitted bid, through CPP portal before the last date and time of submission of bid.
D. BID OPENING AND EVALUATION	
1.21 Bid Opening	1.21.1 The bid will be opened online at the time of opening of bids, the tenderer can view the bid opening event online at their remote end also. 1.21.2 In the event of any of the above mentioned tender opening date being declared as a holiday/ closed day for WAPCOS Ltd., the tenders will be opened on the next working day at the appointed time.
1.22 Process to be Confidential	1.22.1 After the opening of bids, information relating to the examination, clarification, evaluation and comparison of bids and recommendation concerning the award of Contract shall not be disclosed to bidders or other person not officially concerned with such process. 1.22.2 Any effort by a bidder to influence WAPCOS in the process of examination, clarification, evaluation and comparison of bids, and in decisions concerning award of Contract, may result in the rejection of his bid. 1.22.3 The Contractor shall not communicate or use in advertising, publicity or in any other medium, photograph or other reproduction of the Works under this Contract, or description of the site, dimensions, quantity, quality or other information, concerning the Works unless prior written permission has been obtained from the General Manager (GWRDM), WAPCOS, New Delhi . 1.22.4 All documents, correspondence, decisions and other matters concerning the Contract shall be considered confidential and of restricted nature by the Contractor and he shall not divulge or allow access thereto by any unauthorized persons.
1.23 Clarification of Bids	During technical evaluation of tenders, the department may, at its discretion, ask the bidder for a clarification of its tender, for which no charges shall be paid to the bidder. The request for clarification and the response shall be in writing and no change in prices or substance of the Tender shall be sought, offered or permitted. Canvassing whether directly or indirectly, in connection with tenders is strictly prohibited and the tenders submitted by the tenderer who resort to canvassing will be liable to rejection.
1.24 Determination of Responsiveness	1.24.1 The bidder has to quote his rates as indicated in Instruction to bidders. 1.24.2 Prior to the detailed evaluation of bids, WAPCOS will determine whether each technical bid is techno-commercially substantially responsive to the requirements of the Bidding Documents. 1.24.3 For the purpose of the Para.1.24 a substantially responsive bid is one which fulfills the Eligibility and Qualification Requirements in accordance with Para 1.2 and conforms to all the terms, conditions and specifications of the Bidding Documents without material deviation or reservation. A material deviation or reservation is one which affects in any substantial way the

	<p>scope, quality, or performance of the Works, or which limits in any substantial way, inconsistent with the Bidding Documents, WAPCOS' has rights or the bidder's obligations under the Contract and the rectification of which deviation or reservation would affect unfairly the comparative position of other bidders presenting substantially responsive bids.</p> <p>1.24.4 The technical evaluation shall be made for the bidder's proposed method of Construction, Construction programme, order / sequence of the Work and proposed resources assigned to do the Work to determine his capability.</p> <p>1.24.5 If the technical bid is not substantially responsive to the requirements of the Bidding Documents, or the proposed construction methods are clearly impracticable, it will be rejected by WAPCOS and may not subsequently be made responsive by the bidder having corrected or withdrawn the non-conforming deviation or reservation.</p> <p>1.24.6 The price bids of only those bidders will be considered whose Techno-Commercial bids have been found to be substantially responsive to the requirements of the Bidding Documents. The date and venue for the opening of the price bid shall be notified separately and communicated to the eligible and technically qualified bidders .The price bids along with bid securities of the bidders whose Techno- Commercial bids have been declared non-responsive, shall be returned unopened to the bidders. The price bid of qualified bidders shall be opened in the presence of the intending bidders or their authorized representatives who wish to be present, on notified date by WAPCOS.</p>
1.25 Correction of Errors	<p>The price bid shall be checked by WAPCOS for any arithmetic errors in computation and summation. Errors will be corrected by WAPCOS as follows:</p> <p>(i) Where there is a discrepancy between the rate/ amount in figures</p> <p>(ii) Where there is a discrepancy between the unit rate and the total amount derived from the multiplication or addition of the unit rate and the quantity, the unit rate as quoted will govern.</p>
1.26 Evaluation and Comparison of Tenders	<p>1.26.1 WAPCOS will evaluate tenders and award the Contract to the techno-commercially acceptable responsive contractors offering the lowest Evaluated Tender Price.</p> <p>1.26.2 WAPCOS reserves the right to accept or reject any variation, deviation or alternative offers. Variations, deviations, alternative offers and other factors which are in excess of the requirements of the Tender Document or otherwise result in the accrual of unsolicited benefits to WAPCOS shall not be taken into account in tender evaluation.</p>
E. AWARD OF CONTRACT	
1.27 Award Criteria	<p>The Employer will award the contract to the successful Bidder whose bid has been determined to be substantially responsive to be bidding documents and who has offered Lowest Bid Price.</p>
1.28 WAPCOS's Right to Accept any Bid and to Reject any or all Bids	<p>The Employer reserves the right to accept or reject any bid, and to annul the bidding process and reject all' bids at any time prior to award of contract, without thereby incurring any liability to the affected Bidder or bidders or any obligation to inform the affected Bidder or bidders of the grounds for the Employer's action.</p>

<p>1.29 Notification of Award</p>	<p>1.29.1 Prior to the expiration of the period of bid validity prescribed by WAPCOS or any extension thereof, WAPCOS will notify the successful bidder in writing by registered letter, that his bid has been accepted.</p> <p>1.29.2 The notification of award will constitute the formation of the Contract.</p> <p>1.29.3 Upon the furnishing by the successful bidder of a Performance Security in accordance with the provisions of para 1.31, WAPCOS will promptly notify the unsuccessful bidders that their bids have been unsuccessful.</p>
<p>1.30 Signing of Agreement</p>	<p>1.30.1 Within 7 (Seven) days of issue of the Letter of Acceptance, on a date and time mutually agreed upon, the successful bidder or his authorized representative shall attend the office of the General Manager (GWRDM), for signing of the Agreement. The Performa for Agreement is as at Annex – III.</p> <p>1.30.2 Failure of the successful bidder to comply with the requirement of Para 1.30.1 will constitute sufficient grounds for the annulment of the award and forfeiture of the Earnest Money Deposit.</p>
<p>1.31 Performance Security</p>	<p>1.31.1 Within 07 (Seven) days of the receipt of the notification of award (issue of letter of acceptance) from WAPCOS but not later than the date of the signing of the agreement, the successful bidder shall furnish to WAPCOS two Performance Securities:</p> <ul style="list-style-type: none"> a) A performance security for compenent of drilling of Piezometer in the form of a bank guarantee for an amount of 5% (Five percent) of the contract price in accordance with the conditions of the contract and should remain valid for a period of 60 days beyond the date of completion of all contractual obligations of contractor including maintenance period. The performance security shall be refunded to the contractor after completion of the work, duly issue of completion certificate by GMDA’s authorities and taking over of completed work and after expiry of maintenance period which ever is later. b) A performance security for compenent of supply, installation and commissioning of Digital Water Level Recorder in the form of a bank guarantee for an amount of 5% (Five percent) of the contract price in accordance with the conditions of the contract and should remain valid for a period of 60 days beyond the date of completion of all contractual obligations of contractor including maintenance period. The performance security shall be refunded to the contractor after completion of the work, duly issue of completion certificate by GMDA’s authorities and taking over of completed work and after expiry of maintenance period which ever is later. <p>1.31.2 The performance security provided by the successful bidder in the form of Bank Guarantee shall be in favour of WAPCOS issued by the any Scheduled Commercial Indian Bank. The Bank Guarantee shall be on the Performa attached at Annex-IV.</p> <p>1.31.3 Failure of the successful bidder to comply with the requirement of Para 1.30 and 1.31 shall constitute sufficient grounds for the annulment of the award and forfeiture of the Earnest Money Deposit.</p> <p>1.31.4 Should the contract period, for whatever reasons be extended, the contractor On the receipt of written request from the Engineer-in-Charge, shall at his own cost get the validity period of Bank Guarantee in respect of Performance Security furnished by him extended and shall furnish the extended/ revised Bank Guarantee to the Engineer-in-Charge, one month before the expiry date of the Bank Guarantee originally furnished.</p>

	1.31.5 The Bank Guarantee should carry the name, designation and power of attorney of the bank official.
1.32 Time Period	The time period for completion of the works is given in table-I. The time period is exclusive of 07 (seven) days for preparation and mobilization of men and equipment.
1.33 Mobilization	The Contractor will be fully responsible for transportation/mobilization, including insurance, of his men and equipment to site. The Contractor has to ensure safe and timely delivery of its equipment to site so as to complete the works within stipulated time period.
1.34 Pin-point of site selection	The pinpoint of site for each well shall be provided by WAPCOS as per instructions and receipt of NOC from GMDA Haryana.
1.33 Signing of the Contract	No payment for the work done will be made unless the contract is signed by the contractor.
1.34 Integrity Pact (IP)	<p>1.34.1 An agreement on prescribed format (Annexure-X) between the prospective bidder and the purchaser, committing the persons/officials of both sides, not to resort to any corrupt practices in any aspect/stage of the contract shall be signed.</p> <p>1.34.2 Only those vendors/bidders, who commit themselves to such a pact by the purchaser, would be considered competent to participate in the bidding process.</p>

General Conditions of Contract

CHAPTER – II
GENERAL CONDITIONS OF CONTRACT
TABLE OF CONTENTS

CLAUSE	TITLE OF CLAUSE
1	Definitions
2	Interpretation
3	Priority of Contract Document
4	Duties and powers of Engineer-in-Charge and Engineer-in-Charge's Representative(s)
5	Assignment
6	Sub-letting
	CONTRACT DOCUMENTS
7	Language and Law
8	Drawings
9	Further Drawings and Instructions
10	Contractor's General Responsibilities
11	Contract Agreement
12	Performance Security
13	Inspection of Site
14	Sufficiency of Bid
15	Works to be to the Satisfaction of Engineer-in-Charge
16	Programme to be Furnished
17	Contractor's Superintendence
18	Contractor's Employees
19	Setting out
20	Site Report
21	Watching and Lighting
22	Care of Works
23	Insurance of Plant & Equipment
24	Damage to persons and Property
25	Third Party Insurance
26	Accident or Injury to Workmen
27	Patent Rights and Royalties
28	Interference with traffic and adjoining Properties
29	Extraordinary Traffic
30	Contractor to keep Site clear
31	Clearance of Site on Completion
32	Labour
33	Material and Workmanship
34	Inspection of Operations
35	Examination of Work Before covering up
36	Removal of Improper Work and Materials
37	Suspension of Work
38	Commencement of Works
39	Possession of Site
40	Time for Completion
41	Extension of Time for Completion

42	Shift Works
43	Rate of Progress
44	Liquidated Damages for Delay
45	Certification of Completion of Works
46	Maintenance and Defects
47	Contractor to Search
	ALTERNATIONS, ADDITIONS, OMISSIONS AND EXTRA ITEMS
48	Variations
49	Extra Items
	PLANT, EQUIPMENT, TEMPORARY WORKS AND MATERIALS
50	Equipment, Temporary Works and Materials
51	Approval of Materials etc. not implied
	MEASUREMENT
52	Quantities
53	Works to be Measured
54	Method of Measurement
55	Key Personnel
56	Certificates and Payment
57	Security Deposit
58	Approval only by Maintenance Certificate
59	Maintenance Certificate
60	Remedies and Powers
61	Urgent Repairs
62	Special Risks/Termination of Contract
	FRUSTRATION
63	Payment in Event of Frustration
64	Solvency Certificate
65	Notices
66	Default of WAPCOS
	CHANGES IN COSTS AND LEGISLATION
67	Increase or Decrease of Costs
68	Taxation
69	Bribery and Collusion
70	Termination of Contract for WAPCOS's Convenience
71	Contractor's near Relatives Employed on the Project
72	Retired Officers Taking up Contract
73	Settlement of Disputes
	GAURANTEE AND LIABILITIES FOR DWLR
74	WARRANTY
75	SERVICE LEVEL CONDITIONS
	DEFINITIONS
76	Joint Venture/Consortium

CHAPTER – II
GENERAL CONDITIONS OF CONTRACT

Definitions	
Clause –1	<p>In the Contract, as hereinafter defined, the following words and expressions shall have the meanings hereby assigned to them, except where the context otherwise requires:</p> <ul style="list-style-type: none">i) "WAPCOS" means WAPCOS Ltd. who will employ the Contractor.ii) "Contractor" means the person or persons, firm or company whose bid has been accepted by WAPCOS and includes the Contractor's personal representatives, successors and permitted assigns.iii) "Engineer-in-Charge" means the Geologist/ Geophysisit/ Engineer-in-Charge appointed from time to time by WAPCOS and notified in writing to the Contractor to act as the Engineer-in-Charge for the purposes of the Contract.iv) "Engineer-in-Charge's Representative" means any Resident Engineer or assistant of the Engineer-in-Charge appointed from time to time by WAPCOS or the Engineer-in-Charge to perform the duties mentioned in Clause-2 hereof, whose authority shall be notified in writing to the Contractor by the Engineer-in-Charge.v) "Works" shall include both Permanent Works and Temporary Works.vi) "Temporary works" means all temporary works of every kind required in or about the execution or maintenance of Works.vii) "Permanent Works" means the permanent works to be executed and maintained in accordance with the Contract.viii) "Contract" means the Conditions Governing the Contract, Technical Specifications, Drawings, priced Bill of Quantities, Letter of Acceptance and the Contract Agreement.ix) "Contract Price" or "Contract Value" means the sum indicated in the Letter of Acceptance.x) "GST" means Goods and Service Taxxi) "Plant and Equipment" or "Machinery" means and include plant, equipment, machinery, tools, appliances, other implements of all description or things of whatsoever nature required in or about the execution, or maintenance of the Works but does not include materials or other things intended to form or forming part of the

Permanent Works.

- xii) "Specifications" means the Technical specifications and other Specifications referred to in the Bidding Documents and any modification thereof or addition thereto or deduction there from as may from time to time be furnished or approved in writing by the Engineer- in-Charge.
- xiii) "Drawings" means the drawings referred to in the Specifications and any modification of such drawings approved in writing by the Engineer-in-Charge and such drawings, as may, from time to time, be furnished or approved in writing by the Engineer-in-Charge.
- xiv) "Site" means the land and other places on, under, in or through which the Permanent Works or Temporary Works, designed by the Engineer-in-Charge are to be executed and any other lands and places provided by WAPCOS for the purposes of working space or any other purpose as may be specifically designated in the Contract or subsequently approved as forming part of site.
- xv) "Approved" means approved in writing, including subsequent written confirmation of previous verbal approval and "approval" means approval in writing including as aforesaid.
- xvi) "Dy. Chief Geologist" means the Dy. Chief Geologist-in-Charge of the Works or his successor and to whom the Engineer-in-Charge reports.
- xvii) "Gol" means Government of India.
- xviii) "Sub-Contractor" means the party or parties having direct contract with the Contractor and to whom any part of the Contract has been sublet by the Contractor with the consent, in writing, of the Engineer-in-Charge.
- xix) "Manufacturer" means the party proposing to manufacture the equipment and materials as specified complete or in part.
- xx) "Letter of Acceptance" means the letter from WAPCOS conveying acceptance of the bid subject to such reservations as may have been stated therein.
- xxi) "Tonne or Metric Tonne" means 1,000 kgs (one thousand kilograms). Metric system shall be followed in all interpretation and execution of Works under this Contract. Any conversion found necessary shall be in accordance with the figures given in 'Indian Standard'; IS 786-1967 and subsequent revision(s) of this Standard.
- xxii) "B.I.S." means Bureau of Indian Standard specifications with latest amendments or revisions as currently in force at the time of execution of the Works.

	<p>xxiii) "Day" means a day from midnight to midnight.</p> <p>xxiv) "Month" means from the beginning of a given date of a calendar month to the end of the preceding date of the next calendar month.</p> <p>xxv) "Week" means seven consecutive days.</p> <p>xxvi) "Shift" means total number of hours which each group of workers have to operate for the day.</p> <p>xxvii) "Quarter" means a period of three consecutive months starting from January, April, July and October i.e. January to March, April to June, July to September and October to December.</p> <p>xxviii) "Near Relative" means wife/husband, parents and grandparents, children, first cousins, brothers-in-law, sisters-in-law and parents-in-law.</p> <p>xxix) "Words in singular number shall include the plural number and vice-versa where the context so requires. "He" shall include "She" and vice-versa.</p> <p>xxx) "Cost" mean all expenditure properly incurred or to be incurred whether on or off the site including overhead and other charges allocable thereto but does not include any allowance for profit.</p> <p>xxxi) GMDA means Faridabad Metropolitan Development Authority, Haryana.</p> <p>The headings in these conditions of the Contract shall not be deemed to be part thereof or be taken into consideration in the interpretation or construction thereof or of the Contract.</p>
<p>Clause – 2</p>	<p>Interpretation</p> <p>Where the context so requires words imparting the singular or masculine term also include plural or feminine and vice versa. Headings have no significance. Words have their normal meaning under the language of the Contract unless especially defined.</p> <p>If the Contractor discovers any ambiguity, omission, error, faults and other defect in the Contract Documents, he shall immediately notify the same in writing to the Engineer, who will resolve the ambiguity or correct the error and will notify the Contractor of the interpretation to be adopted.</p>
<p>Clause – 3</p>	<p>Priority of Contract Document</p> <p>The documents forming the Contract are to be taken as mutually explanatory of one another. For the purposes of interpretation, the priority of the documents shall be in accordance with the following sequence:</p> <p>a) the Contract Agreement</p>

	<ul style="list-style-type: none"> b) the Letter of Acceptance c) the Letter of Tender with priced Bill of Quantities, d) these Conditions of Contract e) the Specification, f) the Drawings, and g) the Schedules and any other documents forming part of the Contract.
<p>Clause – 4</p>	<p>Duties and powers of Engineer-in-Charge and Engineer-in-Charge's Representative(s).</p> <ul style="list-style-type: none"> i) The Engineer-in-Charge shall carry out such duties in issuing decisions, certificates and orders as are specified in the Contract. ii) The Engineer-in-charge's representative(s) shall be responsible to the Engineer-in- Charge, and his duties are to watch and supervise the Works and to test and examine any materials to be used or workmen employed in connection with the Works. He shall have no authority to relieve the Contractor of any of his duties or obligations under the Contract nor, except as expressly provided hereunder or elsewhere in the Contract, to order any Work involving delay or any extra payment by the Engineer-in-Charge, nor to make any variation of or in the Works. iii) The Engineer-in-Charge may, from time to time in writing, delegate to the Engineer-in-Charge's Representative(s) any of the powers and authorities vested in the Engineer-in-Charge and shall furnish to the Contractor a copy of all such written delegations of Powers and authorities. Any written instructions or approval given by the Engineer-in- Charge's Representative(s) to the Contractor within the terms of such delegation, but not otherwise, shall bind the Contractor as though it had been given by the Engineer-in-Charge. Provided always as follows: <ul style="list-style-type: none"> a) Failure of the Engineer-in-Charge's Representative(s) to disapprove any Work or materials shall not prejudice the powers of the Engineer-in-Charge thereafter to disapprove such Work or materials and to order the pulling down, removal or breaking up thereof. b) If the Contractor shall be dissatisfied by reason of any decision of the Engineer-in-Charge's Representative(s), he shall be entitled to refer the matter to the Engineer-in-Charge, who shall there upon confirm, reverse or vary such decision.
<p>Clause –5</p>	<p>Assignment</p> <p>The Contractor shall not assign the Contract or any part thereof, or any benefit or interest therein of there under, otherwise than by a charge in favour of the Contractor's bankers of any money due or to become due under this Contract, without the prior written consent of WAPCOS.</p>

Clause – 6	<p>Sub-letting</p> <p>The Contractor shall not sub-let the whole/part of the Works. Except where otherwise provided by the Contract, the Contractor shall not sub-let any part of the Works without the prior written consent of the Engineer-in-Charge.</p>
CONTRACT DOCUMENTS	
Clause –7	<p>Language and Law</p> <p>i) a) The Contract documents shall be drawn up in English. All correspondence and documents relating to the bid, exchanged by the bidder and WAPCOS, shall be submitted in the prescribed form in English. All supporting documents and printed literature in connection with the bid shall be in English.</p> <p>b) The Law, which shall apply to the contract, is to be subject and according to which the contract is to be construed shall be the law for the time being in force in India within the jurisdiction of Delhi High Courts, New Delhi.</p> <p>ii) Documents Mutually Explanatory</p> <p>Several documents forming the Contract are to be taken as mutually explanatory of one another, but in case of ambiguities or discrepancies, the documents shall take precedence in the order in which they are set out in the Performa of Agreement (Annex III).</p>
Clause – 8	<p>Drawings</p> <p>i) Custody of Drawings</p> <p>The drawings shall remain in the sole custody of the Engineer-in-Charge, but two copies thereof shall be furnished to the Contractor free of charge. The Contractor shall provide and make, at his own expense, any further copies required by him. At the completion of the Contract, the Contractor shall return to the Engineer-in-Charge all drawings provided under the contract. One copy of the drawings, furnished to the Contractor as aforesaid, shall be kept by the Contractor on the Site.</p>
Clause – 9	<p>Further Drawings and Instructions</p> <p>The Engineer-in-Charge shall have full power and authority to supply to the Contractor from time to time, during the progress of the Works, such further drawings and instructions as shall be necessary for the purpose of the proper and adequate execution and maintenance of the Works. The Contractor shall carry out and be bound by the same.</p>
Clause – 10	<p>Contractor's General Responsibilities</p> <p>i) The Contractor shall, subject to the provisions of the Contract, and with due care and diligence, execute and maintain the Works and provide all labour, including the supervision thereof, materials, equipment and all other things, whether of a temporary or permanent nature, required in and for such execution and maintenance, so far as the necessity for providing the same is specified in or is reasonably to be inferred from the Contract.</p> <p>ii) The Contractor shall take full responsibility for the adequacy, stability</p>

	<p>and safety of all site operations and methods of construction, provided that the Contractor shall not be responsible, except as may be expressly provided in the Contract, for the design or specification of the Permanent Works, or for the design or specification of any Temporary Works prepared by the Engineer-in-Charge.</p> <p>iii) The Contractor shall promptly inform the Engineer-in-Charge of any error, omission, fault and other defect in the design or specifications for the Works which are discovered when reviewing the Bidding Documents or in the process of execution of the Works.</p> <p>iv) Where no specifications have been laid down, the materials used and the Work done shall confirm to the relevant B.I.S. Code or any Internationally accepted Standards or as directed by the Engineer-in-Charge.</p> <p>v) All instructions and orders given by the Engineer-in-Charge at site are to be maintained in the Site Instruction Book and shall be taken to have been conveyed to the Contractor for his compliance.</p> <p>vi) The Contractor must have arrangements to receive normal correspondence on working days and urgent correspondence on all days.</p>
Clause-11	<p>Contract Agreement</p> <p>The Contractor shall, when called upon so to do, enter into and execute a Contract Agreement, to be prepared and completed at the cost of Contractor in the Proforma annexed with such modification as may be necessary.</p>
Clause-12	<p>Performance Security</p> <p>i) For the due performance of the contract, the Bid shall contain an undertaking by the contractor to obtain, when required, a guarantee of bank to be jointly and severally bound with the Contractor to WAPCOS in a sum not exceeding that stated in the Letter of Acceptance for such guarantee, the said bank and the terms of the said guarantee shall be such as shall be approved by WAPCOS. The obtaining of such guarantee and the cost of the guarantee to be so entered into shall be at the expense in all respects of the contractor, unless the Contractor otherwise provides.</p> <p>ii) Within 14 (Fourteen) days of the receipt of the notification of award (issue of letter of acceptance) from WAPCOS but not later than the date of the signing of the agreement, the successful bidder shall furnish to WAPCOS two Performance Securities:</p> <p>a) A performance security for component of drilling of Piezometer in the form of a bank guarantee for an amount of 5% (Five percent) of the contract price in accordance with the conditions of the contract and should remain valid for a period of 60 days beyond the date of completion of all contractual obligations of contractor including maintenance period. The performance</p>

	<p>security shall be refunded to the contractor after completion of the work, duly issue of completion certificate by GMDA's authorities and taking over of completed work and after expiry of maintenance period which ever is later.</p> <p>b) A performance security for compenent of supply, installation and commissioning of Digital Water Level Recorder in the form of a bank guarantee for an amount of 5% (Five percent) of the contract price in accordance with the conditions of the contract and should remain valid for a period of 60 days beyond the date of completion of all contractual obligations of contractor including maintenance period. The performance security shall be refunded to the contractor after completion of the work, duly issue of completion certificate by GMDA's authorities and taking over of completed work and after expiry of maintenance period which ever is later.</p> <p>iii) The performance Security will be released by WAPCOS, after the issue of the Maintenance Certificate and Completion Certificate both which ever is later.</p>
<p>Clause-13</p>	<p>Inspection of Site</p> <p>i) The Contractor shall be responsible for his own interpretation.</p> <p>ii) The Contractor shall also be deemed to have been fully aware of the Site and its surroundings and information available in connection therewith and to have satisfied himself, so far as is practicable, before submitting his bid, as to the form and nature thereof, including the subsurface conditions, the hydrological and climatic conditions, the extent and nature of work, and materials necessary for the completion of the Works, means of access to the Site and the accommodation he may require and in general, shall be deemed to have obtained all necessary information, subject as above mentioned, as to risk contingencies and all other circumstances which may influence or affect his Bid.</p>
<p>Clause –14</p>	<p>Sufficiency of Bid</p> <p>The Contractor shall be deemed to have satisfied himself before bidding as to the correctness and sufficiency of his Bid for the Works and of the rates and prices stated in the priced Bill of Quantities and the Schedule of Rates and Prices, if any, which Bid rates and prices shall, except in-so-far as it is otherwise provided in the Contract, which shall cover all his obligations under the Contract, and all matters and things necessary for the proper execution and maintenance of the Works.</p>
<p>Clause –15</p>	<p>Works to be to the Satisfaction of Engineer-in-Charge</p> <p>Save in-so-far as it is legally or physically impossible the Contractor shall execute and maintain the Works in strict accordance with the Contract to the satisfaction of the Engineer-in-Charge and shall comply with and adhere strictly to the Engineer-in- Charge's instructions and directions on any matter whether mentioned in the Contract or not, touching or concerning the Works. The Contractor shall take instructions and directions only from the Engineer-in-Charge.</p>

<p>Clause – 16</p>	<p>Programme to be furnished</p> <ul style="list-style-type: none"> i) Within a period of seven days of issue of letter of acceptance by WAPCOS, the Contractor shall submit to the Engineer-in-Charge for his approval, two copies of a construction programme showing the order of procedure in which he proposes to carry out the Works. ii) The detailed construction programme submitted by the Contractor for orderly completion of the Works, shall show planned sequence of operations and the dates for commencement and completion of all salient feature of the Works so as to complete the works in scheduled time. iii) The programme shall cover activities on the Site and procurement and delivery activities.
<p>Clause –17</p>	<p>Contractor's Superintendence</p> <p>The Contractor shall give or provide all necessary superintendence during the execution of the Works and as long thereafter as the Engineer-in-Charge may consider necessary for the proper fulfilling of the Contractor's obligations under the Contract. The Contractor, or a competent and authorized agent or representative approved of in writing by the Engineer-in-Charge, which approval may at any time be withdrawn, is to be constantly on the Works and shall give his whole time to the superintendence of the same. If such approval shall be withdrawn by the Engineer-in-Charge, the Contractor shall, as soon as is practicable, having regard to the requirement of replacing him as hereinafter mentioned, after receiving written notice of such withdrawal, remove the agent from the Works and shall not thereafter employ him again on the Works in any capacity and shall replace him by another agent approved by the Engineer-in-Charge. Such authorized agent or representative shall receive, on behalf of the Contractor, directions and instructions from the Engineer-in-Charge.</p>
<p>Clause –18</p>	<p>Contractor's Employees</p> <ul style="list-style-type: none"> i) The Contractor shall provide and employ on the Site in connection with the execution and maintenance of the Works: <ul style="list-style-type: none"> a) Only such technical assistants as are skilled and experienced in their respective trades and such sub-agents, foremen and leading hands as are competent to give proper supervision to the work they are required to supervise, and b) Such skilled, semi-skilled and unskilled labour as is necessary for the proper and timely execution and maintenance of the Works. ii) The Engineer-in-Charge shall be at liberty to object to and require the Contractor to remove forthwith from the Works any person employed by the Contractor in or about the execution or maintenance of the Works who, in the opinion of the Engineer-in-Charge, misconducts himself or is incompetent or negligent in the proper performance of his duties, or whose employment is otherwise considered by the Engineer-in-Charge to be undesirable

	<p>and such persons shall not be again employed upon the Works without the written permission of the Engineer-in-Charge. Any person so removed from the Works shall be replaced as soon as possible by a competent substitute approved by the Engineer-in-Charge.</p>
Clause – 19	<p>Setting out</p> <p>The Contractor shall be responsible for properly locating the deepwells in relation to report given by the Engineer-in-Charge in writing and for the correctness, of the position, levels, dimensions of all parts of the Works and for the provision of all necessary instruments, appliances and labour in connection therewith. If, at any time during the progress of Works, any error shall appear or arise in the position, levels, dimensions of the Works, the Contractor, on being required so to do by the Engineer-in-Charge or the Engineer-in-Charge's Representative, shall at his own cost, rectify such error to the satisfaction of the Engineer-in-Charge or the Engineer-in-Charge Representative, unless such error is based on incorrect data supplied in writing by the Engineer-in-Charge or the Engineer-in-Charge's Representative, in which case the expense of rectifying the same shall be borne by WAPCOS. The checking of any setting out of deep well regarding location, dimensions or level by the Engineer-in-Charge or the Engineer-in-Charge's Representative shall not in any way relieve the Contractor or his responsibility for the correctness thereof and the Contractor shall carefully protect and preserve all control points and other things used in locating the deep well.</p>
Clause –20	<p>Site Report</p> <p>The Contractor, in preparing the bid, shall rely on any site investigation reports referred to in contract data, supplemented by any information available to the bidder.</p>
Clause – 21	<p>Watching and Lighting</p> <p>i) The Contractor shall, in connection with the Works, provide and maintain at his own cost, all lights, guards, fencing and watching when and where necessary or required by the Engineer-in-Charge or the Engineer-in-Charge's Representative, or by any duly constituted authority, for the protection of the Works, or for the safety and convenience of the public or others.</p> <p>ii) The Contractor shall also be responsible for temporary roadways, footways, guards, fences, caution notices etc. as far as the same may be rendered necessary by reason of the Work for the pedestrians or other traffic and owners and occupiers of the adjacent property and of the public and shall remain responsible for any accidents that may occur on account of his failure to take proper and timely precautions. In default thereof, the Engineer-in-Charge may provide such fencing, lights, ventilation and watchmen as he may deem necessary and charge the cost thereof to the Contractor.</p>
Clause – 22	<p>Care of Works</p> <p>i) The Contractor shall take full responsibility for the care of the</p>

Works from the date of Commencement of Works until the date of issue of the maintenance Certificate for the whole/part of the Works.

- ii) In the event of any loss or damage to the Works or any part thereof; during the period for which the Contractor is responsible for the care thereof, from any cause whatsoever, other than the risks defined in Sub-Clauses (v) & (vi) of this Clause, the Contractor, at his own cost, shall rectify such loss or damage so that the Permanent Works conform in every respect with the provisions of the Contract to the satisfaction of the Engineer-in-Charge. The Contractor shall also be liable for any loss or damage to the Works occasioned by him in the course of any operation carried out by him for the purpose of complying with his obligations.
- iii) In the event of any loss or damage to the Permanent Works which may occur or arise out of any of the Risks defined in Sub-Clause (v) of this Clause, the same shall be made good/rectified by the Contractor, if and to the extent required by the Engineer-in-Charge, at the cost of WAPCOS which sum shall be determined by the Engineer-in-Charge.
- iv) In the event of any loss or damage which may occur or arise out of any of the risks defined in Sub-Clause (vi) of this Clause, neither party to the Contract shall be liable to the other for any such loss or damage. However, in the event of any loss or damage to the Permanent Works arising as a consequence of the risk(s) defined in Sub-Clause (vi) of this Clause the same shall be made good/rectified by the Contractor at the cost of WAPCOS which sum shall be determined by the Engineer-in-Charge under the provisions of the Contract.
- v) WAPCOS 's risks are as under:
 - a) loss or damage due to the use or occupation by WAPCOS of any section or part of the Permanent Works except as may be provided for in the Contract.
 - b) loss or damage to the extent that it is due to the design of the Works other than any part of the design provided by the Contractor.
- vi) Force Majeure / Excepted risks are as under:
 - a) war, hostilities whether war be declared or not, invasion, act of foreign enemies, act of public enemies.
 - b) ionizing, radiation or contamination by radio activity from any nuclear fuel, radioactive toxic explosive or other hazardous properties of any explosive nuclear assembly.
 - c) Pressure waves caused by aerial devices traveling at supersonic speeds.
 - d) Riot, commotion or disorder unless solely restricted to

	<p>employees of the Contractor and arising from the conduct of the Works.</p> <p>e) Any operation of the forces of nature against which an experienced Contractor could not reasonably have been expected to take precautions.</p>
Clause – 23	<p>Insurance of Plant & Equipment</p> <p>The Contractor shall take insurance cover to the replacement value, for the equipment and other things brought on to the site by him.</p>
Clause – 24	<p>Damage to persons and Property</p> <p>The Contractor shall, except if and so far as the Contract provides otherwise, indemnify WAPCOS against all losses and claims in respect of injuries or damage to any persons or material or physical damage to any property whatsoever which may arise out of or in consequence of the execution and maintenance of the Works and against all claims, proceedings, damages, costs, charges and expenses whatsoever in respect of or in relation thereto except any compensation or damages for or with respect to injuries or damage to persons or property resulting from any act or neglect of WAPCOS, servants, or other Contractors, not being employed by the Contractor, or for or in respect to any claims, proceedings, damages, costs, charges and expenses in respect thereof or in relation thereto or where the injury or damage was contributed to by the Contractor, his servants or agents, such part of the compensation as may be just and equitable having regard to the extent of the responsibility of WAPCOS, its servants or agents or other Contractors for the damage or injury.</p>
Clause– 25	<p>Third Party Insurance</p> <p>i) Before commencing the execution of the works the Contractor, but without limiting his obligation and responsibilities under Clause – 24 hereof, shall insure against his liability for any material or physical damage, loss or injury which may occur to any property, including any employee of WAPCOS, by or arising out of the execution of the Works or in the carrying out of the Contract , otherwise , than due to the matters referred to in the provision to Clause-24 hereof.</p> <p>The contractor shall, whenever required, produce to the Engineer-in-charge or the Engineer-in-charge’s Representative the original policy or policies of insurance and the receipts for payment of the current premiums and furnish attested copies thereof.</p> <p>ii) Provision to Indemnify WAPCOS, The terms shall include a provision whereby, in the event of any claim in respect of which the Contractor would be entitled to receive indemnity under the policy being brought or made against WAPCOS, the insurer will indemnify WAPCOS against such claims and any costs, charges and expenses in respect thereof.</p>

<p>Clause – 26</p>	<p>Accident or Injury to Workmen</p> <p>i) WAPCOS shall not be liable for or in respect of any damages or compensation payable according to law in respect or in consequence of any accident or injury to any workman or other person in the employment of the Contractor or any sub-Contractor, save and except an accident or injury resulting from any act or default of WAPCOS, or servants. The Contractor shall indemnify and keep indemnified WAPCOS against all such damages and compensation, save and except as aforesaid, and against all claims, proceedings, costs, charges and expenses whatsoever in respect thereof or in relation thereto.</p> <p>ii) On the occurrence of accident arising out of the Works which result in death, or which is so serious as to be likely to result in death, the Contractor shall, within twenty four hours of such accident, report in writing to the Engineer-in-Charge and other statutory bodies of the Government the facts stating clearly and in sufficient details the circumstances of such accident and the subsequent action. All other accidents of the Works involving injuries to persons or damage to property other than that of the Contractor shall be promptly reported to the Engineer-in-Charge and other statutory bodies of the Government stating clearly and in sufficient details of the facts and circumstances of the accidents and the action taken. In all cases the Contractor shall indemnify WAPCOS against all loss or damage resulting directly or indirectly from the Contractor's failure to report in the manner aforesaid. This includes penalties or fines, if any, payable by WAPCOS as a consequence of failure to give notice or failure to conform to the provisions of any Act in regard to such accidents.</p> <p>iii) Insurance against Accident, etc., to Workmen</p> <p>The Contractor shall insure against such liability with an insurer approved by WAPCOS, which approval shall not be unreasonably withheld, and shall continue such insurance during the whole of the time that any persons are employed by him on the Works and shall, when required, produce to the Engineer-in-Charge or the Engineer-in-Charge's Representative such policy of insurance and the receipt for payment of the current premium. Provided always that, in respect of any persons employed by any sub-Contractor, the Contractor's obligation to insure as aforesaid under this sub-clause shall be satisfied if the sub-Contractor shall have insured against the liability in respect of such persons in such manner that WAPCOS is indemnified under the policy, but the Contractor shall require such sub-Contractor to produce to the Engineer-in-Charge or the Engineer-in-Charge's Representative, when required, such policy of insurance and the receipt for the payment of the current premium.</p>
<p>Clause – 27</p>	<p>Patent Rights and Royalties</p> <p>i) The Contractor shall save harmless and indemnify WAPCOS from and against all claims and proceedings for or on account of</p>

	<p>infringement of any patent rights, designs, trademark or name or other protected rights in respect of any machine, work, or material used for or in connection with the Works or any of them and from and against all claims, proceedings, damages, costs, charges and expenses whatsoever in respect thereof or in relation thereto. Except where otherwise specified, the Contractor shall pay all tonnage and other royalties, rent and other payments or compensation, if any, for getting stone, sand, gravel, clay, timber or other construction materials required from the Project.</p> <p>ii) In the event of any claims made under or action brought against WAPCOS in respect of any such matters as aforesaid, the Contractor shall be immediately, notified thereof and the Contractor shall be at liberty, at his own expense, to settle any disputes or to conduct any litigation that may arise there from. Provided that the Contractor shall not be liable to indemnify WAPCOS if the infringement of the patent or design or any alleged patent or design right is the direct result of an order passed by the Engineer-in-Charge in this behalf.</p>
<p>Clause-28</p>	<p>Interference with Traffic and Adjoining Properties: All operation necessary for the execution of the Works shall, so far as compliance with the requirements of the Contract permits, be carried on so as not to interfere unnecessarily or improperly with the convenience of the public, or the access to, use and occupation of public or private roads and foot paths to or of properties whether in the possession of WAPCOS or of any person. The Contractor shall save harmless and indemnify WAPCOS in respect of all claims, proceedings, damages, costs, charges and expenses whatsoever arising out of, or in relation to, any such matters in-so-far as the contractor is responsible therefore.</p>
<p>Clause-29</p>	<p>Extraordinary Traffic: i) Protection of Highways and Bridges The Contractor shall use every reasonable means to prevent any of the highways or bridges communicating with or the routes to the Site from being damaged or injury by any traffic of the Contractor or any of his Sub-Contractors and, in particular, shall select routes, choose and use vehicles and restrict and distribute loads so that any such extraordinary traffic, as will inevitably arise from the moving of plant and material from and to Site, shall be limited, as far as reasonably possible, and so that no unnecessary damage or injury may be occasioned to such highways and bridges.</p>
<p>Clause – 30</p>	<p>Contractor to keep Site clear i) During the progress of the Works, the Contractor shall keep the site reasonably free from all unnecessary obstructions and shall store or dispose of any Constructional plant and surplus materials and clear away and remove from the site any wreckage, rubbish or Temporary Works no longer required. ii) In case the Contractor does not keep the area clean and if found necessary to get the area cleaned, the Engineer-in-Charge shall issue a notice of forty eight hours, and in the event of non-compliance by the Contractor, get the area cleaned by some other</p>

	agency. The cost of such cleaning shall be borne by the Contractor.
Clause – 31	<p>Clearance of Site on Completion</p> <p>On the completion of the Works, the Contractor shall clear away and remove from the Site all Constructional Plant, surplus materials, rubbish and Temporary Works of every kind, and leave the whole of the site and Works clean and in a workman like condition to the satisfaction of the Engineer-in-Charge.</p>
LABOUR	
Clause - 32	<p>(i) Engagement of Labour</p> <p>The Contractor shall make his own arrangements for the engagement of all labour local or otherwise, and, save in-so-far as' the Contract otherwise provides, for the transport, housing, feeding and payment thereof. The Contractor shall not employ in connection with the Works any person who has not completed 18 years of age. No female labour shall be employed.</p> <p>(ii) Supply of Water</p> <p>The Contractor shall, having regard to local conditions, provide on the Site, to the satisfaction of the Engineer-in-Charge or his Representative, an adequate supply of drinking and other water for the use of the Contractor's staff and workmen.</p> <p>(iii) Alcoholic Liquor & Drugs.</p> <p>The Contractor shall not, otherwise than in accordance with the Statutes, Ordinances and Government Regulations or orders for the time being in force, import, sell, give, barter or otherwise dispose of any alcoholic liquor, or drugs, or permit or suffer any such importation, sale, gift, barter or disposal by his sub-Contractors, agents or employees.</p> <p>(iv) Disorderly Conduct, etc.</p> <p>The Contractor shall, at all times, take all reasonable precautions to prevent any unlawful, riotous or disorderly conduct by or amongst his employees and for the preservation of peace and protection, of persons and property in the neighbourhood of the Works against the same.</p> <p>(v) Contractor to Follow Labour Laws and wage laws of INDIA</p> <p>The Contractor shall, in respect of labour employed by him, comply with the provision of the various labour laws, Minimum Wages issued by Government of India and shall indemnify WAPCOS in respect of all claims that may be made against WAPCOS for non-compliance thereof by the Contractor,</p> <p>Notwithstanding anything contained herein, the Engineer-in-</p>

	<p>Charge may take such actions as may be necessary for compliance of the various labour laws and recover the costs thereof from the Contractor.</p> <p>(vi) Observance by Sub-Contractors</p> <p>The Contractor shall be responsible for observance by his sub-Contractors of the foregoing provisions.</p>
--	--

MATERIALS AND WORKMANSHIP

<p>Clause – 33</p>	<p>Material and Workmanship Material and Workmanship</p> <p>a) The Contractor shall be responsible for arranging all the materials (except the materials to be supplied by WAPCOS) required for the construction of the Works from the source(s) acceptable to WAPCOS. He shall also be responsible for proper transportation and storage of these materials to the satisfaction of the Engineer-in-Charge and shall bear all related costs.</p> <p>b) The Engineer-in-Charge shall be entitled at any reasonable time, to inspect or examine all such materials. The Contractor shall provide reasonable assistance for such inspection or examination as may be required.</p> <p>c) The contractor shall initiate timely action to procure the materials well in advance so as to ensure that the progress of works does not suffer for want of materials at site at least seven days before these are intended to be used on works. Any setback to the progress of the works and consequent delay in completion of the works on account of non availability of materials at site shall be the sole responsibility of the contractor.</p> <p>d) Any assistance that the Engineer-in-Charge can give to the Contractor for arranging the materials shall be provided on a "no responsibility basis".</p> <p>(ii) Quality of materials and Workmanship and Tests</p> <p>(a) The Contractor shall, provide the materials of the quality, kind and specifications as provided in the Contract. The Contractor shall produce to the Engineer-in- Charge, certified quality test reports in respect of the materials procured by him.</p> <p>(b) In case the materials procured by the Contractor are not to the satisfaction of the Engineer-in-Charge and do not conform to the specifications laid in the Contract, such materials shall be rejected by the Engineer-in-Charge and the cost incurred on such procurement shall be the responsibility of the Contractor.</p>
---------------------------	---

	<p>(c) The workmanship shall be of the kind described in the Contract and in accordance with the Engineer-in-Charge's instructions.</p> <p>(d) All the materials and the workmanship shall be subjected, from time to time, to such tests as the Engineer-in-Charge may require at the place of manufacture, fabrication or preparations, or on the Site or at such other or places as may be specified in the Contract, or at all or any of such places. The Contractor shall provide such assistance, instruments, machines, labour and materials as are required for examining, measuring and testing any material and shall supply samples of materials, before incorporation in the Works, for testing, as may be selected and required by the Engineer-in-Charge.</p> <p>(iii) Cost of Samples All samples shall be supplied by the Contractor at his own cost.</p> <p>(iv) Cost of Tests The cost of making any test intended by or provided for in the Contract shall be borne by the Contractor.</p>
Clause-34	<p>Inspection of Operations The Engineer-in-Charge or any person authorized by him shall, at all times, have access to the Works and to all workshops and places where the Work is being prepared or from where materials, manufactured articles or machinery are being obtained for the Works and the Contractor shall afford every facility for and every assistance in or in obtaining the right to such access.</p>
Clause - 35	<p>Examination of Work before covering up i) No Work shall be covered up or put out of view without the approval of the Engineer-in-Charge or his Representative and the Contractor shall afford full opportunity for the Engineer-in-Charge or the Engineer-in-Charge's Representative to examine and measure any work which is about to be covered up or put out of view. The Contractor shall give due notice whenever any such work is or are ready or about to be ready for examination and the Engineer-in-Charge or the Engineer-in-Charge's Representative shall, without unreasonable delay, unless he considers it unnecessary and advises the Contractor accordingly, attend for the purpose of examining and measuring such work.</p>
Clause- 36	<p>Removal of Improper Work and Materials i) The Engineer-in-Charge shall have power to issue instructions from time to time for;</p> <ul style="list-style-type: none"> a) the removal from the Site, within such time or times as may be specified in the instructions, of any materials which, in the opinion of the Engineer-in-Charge, are not in accordance with the Contract, b) the substitution of proper and suitable materials, and c) The removal and proper re-execution, notwithstanding any previous test thereof or interim payment therefore, of any work which in respect of materials or workmanship is not, in the opinion of the Engineer-in-Charge, in accordance with the Contract.

	<p>ii) Default of Contractor in Compliance</p> <p>In case of default on the part of the Contractor in carrying out such instruction, as specified in subclause (i) of this clause, the Engineer-in-Charge shall be entitled to employ and pay other persons to carry out the same and all expenses consequent thereon or incidental thereto shall be recoverable from the Contractor by the Engineer-in-Charge or may be deducted from any money due or which may become due to the Contractor.</p>
<p>Clause-37</p>	<p>Suspension of Work</p> <p>i) The Contractor shall, on the written order of the Engineer-in-Charge, suspend the progress of the Works or any part thereof for such time or times and in such manner as the Engineer-in-Charge may consider necessary and shall, during such suspension, properly protect and secure the Works, or such part thereof, so far as is necessary in the opinion of the Engineer-in-Charge. The extra cost incurred by the Contractor in giving effect to the instructions of the Engineer-in-Charge under this Clause shall be borne and paid by WAPCOS unless such suspension is :</p> <ul style="list-style-type: none"> a) otherwise provided for in the Contract, or b) necessary by reason of some default of or breach of Contract by the Contractor, or c) necessary by reasons of climatic conditions on the Site, or d) necessary for the proper execution of the Works or for the safety of the Works or any part thereof in so far as such necessity does not arise from any act or default by the Engineer-in-Charge or from any of the risks defined in Sub-Clause-20(vi) hereof, <p>Provided that the Contractor shall not be entitled to recover any such extra cost unless he gives written notice of his intention to claim to the Engineer-in-Charge within fifteen days of the order of the Engineer-in-Charge. The Engineer-in-Charge shall settle and determine such extra payment and/or extension of time under Clause-44 hereof to be made to the Contractor in respect of such claim as shall, in the opinion of the Engineer-in-Charge be fair and reasonable.</p>
<p>COMMENCEMENT AND DELAYS</p>	
<p>Clause- 38</p>	<p>Commencement of Works</p> <p>The Contractor shall commence the actual drilling works on Site within a period of seven days after the issue of letter of acceptance</p>
<p>Clause - 39</p>	<p>Possession of Site</p> <p>i) Save in so far as the Contract may prescribe, the extent of portions of the Site of which the Contractor is to be given possession from time to time, and in which such portion shall be made available to the Contractor, and, subject to any requirement in the Contract as to the order in which the Works shall be executed, the Engineer-in-Charge will after issuing written order to commence the Works, give to the</p>

	<p>Contractor possession of so much of the Site as may be required to enable the Contractor to commence and proceed with the execution of the Works in accordance with the programme.</p> <p>The Contractor shall not be allowed to occupy other Government and/or WAPCOS land for temporary use or otherwise without the prior consent of the Engineer-in-Charge.</p> <p>ii) Rights of Way and Facilities</p> <p>The Contractor shall bear all costs and charges for special or temporary rights of way required by him in connection with access to the Site. The Contractor shall also provide, at his own cost, any additional facilities outside the Site required by him for the purpose of the Works.</p>
<p>Clause –40</p>	<p>Time for Completion</p> <p>The period of completion of the whole of the Work shall be as shown in Table-I in tender document. The period of completion shall be reckoned from the date of issue of letter of acceptance to the successful bidder.</p>
<p>Clause – 41</p>	<p>Extension of Time for Completion</p> <p>The time allowed for execution of the Works as specified in the Bidding data or the extended time in accordance with these conditions shall be the essence of the Contract. The execution of the works shall commence from such time period as mentioned in letter of acceptance or from the date of handing over of the site whichever is later. If the Contractor commits default in commencing the execution of the work as aforesaid, WAPCOS shall without prejudice to any other right or remedy available in law, be at liberty to forfeit the earnest money & performance guarantee absolutely. As soon as possible after the Contract is concluded the Contractor shall submit a Time and Progress Chart and get it approved by the Employer. It shall indicate the forecast of the dates of commencement and completion of various trades of sections of the work and may be amended as necessary by agreement between the Employer and the Contractor and further to ensure good progress during the execution of the work, the contractor shall in all cases complete the work as per the schedule.</p> <p>If the work(s) be delayed by:</p> <ul style="list-style-type: none"> (i) force majeure events, or (ii) abnormally bad weather, or (iii) serious loss or damage by fire, or (iv) civil commotion, local commotion of workmen, strike (excluding by Party's employees) or lockout (excluding by Party's employees), affecting any of the trades employed on the work , or (v) delay on the part of other contractors or tradesmen engaged by Employer in executing work not forming part of the Contract, or (vi) any other cause which, in the absolute discretion of the authority mentioned in Bidding Data is beyond the Contractor's control and not brought about at the instance of the Contractor claiming to be affected by such event. <p>Then upon the happening of any such event causing delay, the Contractor shall immediately give notice thereof in writing to the Employer but shall nevertheless use constantly his best endeavours to prevent or make good the delay and shall do all that may be reasonably required to the</p>

	<p>satisfaction of the Employer to proceed with the works. Request for rescheduling of work and extension of time, to be eligible for consideration, shall be made by the Contractor in writing within 14 days of the happening of the event causing delay on the prescribed form. The Contractor may also, if practicable, indicate in such a request the period for which extension is desired. In any such case the authority mentioned in Bidding Data may give a fair and reasonable extension of time. Such extension shall be communicated to the Contractor by the Employer in writing, within 2 months of the date of receipt of such request. Non application by the contractor for extension of time shall not be a bar for giving a fair and reasonable extension by the Employer and this shall be binding on the contractor.</p>
Clause – 42	<p>Shift Works</p> <p>i) To achieve the required progress, the Work may be required to be carried out round the clock. The period of completion and number of working days shall not be affected by the number of shifts each day. No extra amount on account of any shift work is payable to the Contractor.</p> <p>ii) Whenever the Work is carried out at night, adequate lighting of working areas and access paths shall be provided by the Contractor at his cost. Sufficient notice shall be given by the Contractor to the Engineer-in-Charge regarding details of Works in Shift so that necessary supervision could be provided.</p>
Clause – 43	<p>Rate of Progress</p> <p>If for any reason, which does not entitle the Contractor to an extension of time, the rate of progress of the Works at any time is not commensurate with the rate of progress stipulated in Clause (16) of this Clause and in the opinion of the Engineer-in-Charge does not ensure completion by the prescribed time or extended time for completion, the Engineer-in-Charge shall so notify the Contractor in writing and the Contractor shall thereupon take such steps as are necessary and the Engineer-in-Charge may approve to expedite progress so as to complete the Works by the prescribed time or extended time. The Contractor shall not be entitled to any additional payment for taking such steps.</p>
Clause-44	<p>Liquidated Damages for Delay</p> <p>In case of delay in completion of the contract, liquidated damages (for</p> <p>i) repair works costing up to Rs. Ten lakh - one percent of the contract value per week and</p> <p>ii) for all other works half percent of the contract value per week of delay subject to a maximum of ten percent of contract value) should be levied.</p>
Clause – 45	<p>Certification of Completion of Works</p> <p>When the whole of the Works have been substantially completed and have satisfactorily passed any final test that may be prescribed by the Contract, the Contractor may give a notice to that effect to the Engineer-in-Charge or to the Engineer-in-Charge's Representative(s) accompanied by an undertaking mentioning that all the works have been finished. Such notice and undertaking shall be in writing and shall be deemed to be a request by the Contractor for the Engineer-in-Charge to issue a Certificate of Completion in respect of the Works. The Engineer- in-Charge shall, within twenty-one days of the date of delivery of such notice either issue to the</p>

	<p>Contractor, a Certificate of Completion stating the date on which, in his opinion, the Works are substantially completed in accordance with the Contract or give instructions in writing to the Contractor specifying all the Works which, in the Engineer-in-Charge's opinion, are required to be done by the Contractor before the issue of such Certificate. The Engineer-in-Charge shall also notify the Contractor of any defects in the Works affecting substantial completion that may appear after such instructions and before completion of the Works specified therein. The Contractor shall be entitled to receive such Certificate of Completion within twenty-one days of completion to the satisfaction of the Engineer-in-Charge of the Works so specified and making good any defects so notified.</p>
--	--

MAINTENANCE AND DEFECTS

Clause – 46

Maintenance and Defects

- i) Period of Maintenance:
 - a) In respect of Drilling of Piezometer Component:**
In these conditions, the expression "Period of Maintenance" shall mean a period of **12 months** after commissioning of last well and issue of completion certificate whichever is later.
 - b) In respect of Supply, Installation & Commissioning of Digital Water Level Recorder Component:**
In these conditions, the expression "Period of Maintenance" shall mean a period of **five (5) years** after Supply, Installation & Commissioning of last Digital Water Level Recorder and issue of completion certificate whichever is later.
- ii) Execution of Work of Repair etc.

To the intent that the Works shall, at or as soon as practicable after the expiration of the Period of Maintenance be delivered to WAPCOS in the condition required by the Contract, fair, wear and tear excepted, to the satisfaction of the Engineer-in-Charge, the Contractor shall complete the Work, if any, outstanding on the date of completion, as certified under Clause-48 hereof, as soon as practicable after such date and shall execute all such work of repair, amendment, rectification and making good defects, imperfections, other faults as may be required of the Contractor in writing by the Engineer-in-Charge during period of Maintenance or within seven days after its expiration, as a result of an inspection made by or on behalf of the Engineer-in-Charge prior to its expiration.
- iii) Cost of Execution of works of Repair, etc.

All repair works shall be carried out by the Contractor at his own expense if the necessity there of shall, in the opinion of the Engineer-in-Charge be due to the use of materials or workmanship not in accordance with the Contract, or due to neglect or failure on the part of the Contractor to comply with any obligation, expressed or implied, on the Contractor's part under the Contract. If, in the opinion of the Engineer-in-Charge such necessity shall be due to any other cause, the value of such work shall be ascertained and paid for as if it were

	<p>additional work.</p> <p>iv) Remedy on Contractor's Failure to carry out Work Required</p> <p>If the Contractor shall fail to do any such work as aforesaid required by the Engineer-in-Charge, WAPCOS shall be entitled to employ and pay other persons to carry out the same and if such work is the work which, in the opinion of the Engineer-in-Charge, the Contractor was liable to do at his own expense under the Contract, then all expenses consequent there-on or incidental thereto shall be recoverable from the Contractor by the Engineer-in-Charge from any money due or which may become due to the Contractor.</p>
<p>Clause -47</p>	<p>Contractor to Search cause of any defect</p> <p>The Contractor shall, if required by the Engineer-in-Charge in writing, search under the directions of the Engineer-in-Charge for the cause of any defect, imperfection or fault appearing during the progress of the Works and during the period of maintenance. Unless such defect, imperfection or fault is one for which the Contractor is liable under the Contract, the cost of work carried out by the Contractor in searching as aforesaid shall be borne by WAPCOS. If such defect, imperfection or fault shall be one for which the Contractor is liable as aforesaid, the cost of the work carried out in searching as aforesaid shall be borne by the Contractor and he shall in such case repair, rectify and make good such defect, imperfection or fault at his own expense.</p>
<p>ALTERNATIONS, ADDTIIONS, OMISSIONS AND EXTRA ITEMS</p>	
<p>Clause – 48</p>	<p>Variations</p> <p>i) The Engineer-in-Charge shall make any variation in the form, quality or quantity of the Works or any part thereof or substitution for original specifications, design, drawings and instructions that may, in his opinion be necessary and for that purpose, or if for any other reason it shall, in his opinion be appropriate, he shall have power to order the Contractor to do and the Contractor shall do any or all of the following:</p> <ul style="list-style-type: none"> a) increase or decrease the quantity of any work included in the Contract, b) omit or substitute any such work, c) change the character or quality or kind of any such work d) execute additional work of any kind necessary for the completion of the Works, and e) change any specified sequence or timing of construction or any part of the Works. <p>No such variations shall in any way vitiate or invalidate the Contract, but the effect if any, of all such variations shall be valued on which he agreed to do the Work hereof. Provided that where the issue of an instruction to vary the Works is necessitated by some default of or breach of Contract by the Contractor or for which he is responsible, any additional Cost attributable to such default shall be borne by the Contractor. Any altered, additional or substituted work which the Contractor may be directed to do in the manner above specified as part</p>

	<p>of the work, shall be carried out by the Contractor on the same conditions in all respects on which he agreed to do the main Work.</p> <p>ii) The Unit Rates entered in the Bill of Quantities for the individual items shall apply for the quantities of Work as per actual execution of each item. However if quantities are deviated from the quantities specified in tender documents, prior written approval of the competent authority shall be taken before executing the deviated work. In case of deviated work, payment shall only be made for the work for which prior written approval of competent authority has been obtained.</p>
<p>Clause – 49</p>	<p>Extra Items</p> <p>The rates of extra items or deviated items shall be decided based on mutual consent by the Contractor and Engineer-in-Charge. Contractor has to submit his rate analysis as per prevailing market rates in writing within 7 days of the instruction of Engineer-in-Charge to execute the new items. The rate will be reviewed by WAPCOS and acceptable rate will be intimated to the Contractor for acceptance of the same.</p> <p>Under no circumstances, the Contractor shall at any stage suspend the work on account of non-settlement of rates of such varied Work.</p>
<p>PLANT, EQUIPMENT, TEMPORARY WORKS AND MATERIALS</p>	
<p>Clause – 50</p>	<p>Equipment, Temporary Works and Materials</p> <p>i) Contractor to Provide Equipment</p> <p>The Contractor shall provide at his own expense all plant, Temporary Work and Equipment, materials and Camps specified under para 1.1 of Chapter I of this document required for the execution of the Works. He shall furnish alongwith the bid a list of items of all machinery which he shall be deploying on the particular job. He shall also make necessary arrangements for supplementing them at his own expense, if required to do so by the Engineer-in-Charge at the time of acceptance of the Contract, or later on as the Work progresses. He shall also indicate whether he owns the machinery or he proposes to purchase or hire the same and shall furnish proof that he shall be able to arrange this machinery whether from his own resources or on hire.</p> <p>Within fifteen (15) days after the issue of the Letter of Acceptance, the Contractor shall mobilize of all the machines conforming with the list submitted with his bid.</p> <p>ii) Plant etc., Exclusive Use for the Works</p> <p>All Equipment, Temporary Works and materials provided by the Contractor shall, when brought on to the Site, be deemed to be exclusively intended for the execution of the Work and the Contractor shall not remove the same or any part thereof, except for the purpose of moving it from one part of the Site to another, without the consent, in writing, of the Engineer-in-Charge.</p> <p>iii) Removal of equipment & plant etc.</p> <p>Upon completion of the Works, the Contractor shall remove from the</p>

	Site all the said equipment and Temporary works remaining thereon and any unused materials provided by the Contractor.
Clause-51	<p>Approval of Materials etc. not implied</p> <p>The operation of Clause-50 hereof shall not be deemed to imply any approval by the Engineer-in- Charge of the materials or other matters referred to there-in nor shall it prevent the rejection of any such materials at any time by the Engineer-in-Charge.</p>
MEASUREMENT	
Clause-52	<p>Quantities</p> <p>The quantities set out in the Bill of Quantities are the estimated quantities of the Work, but they are not to be taken as the actual quantities of the Works to be executed by the Contractor in fulfilment of his obligations under the Contract.</p>
Clause –53	<p>Works to be measured</p> <p>The Engineer-in-Charge and GMDA, HARYANA representative shall, except as otherwise stated, ascertain and determine by measurement the value in terms of the Contract of work done in accordance with the Contract.</p> <p>He shall, when he requires any part or parts of the Works to be measured, give notice to the Contractor's authorised agent or representative, who shall forthwith attend or send a qualified agent to assist the Engineer-in-Charge in making such measurement, and shall furnish all particulars required by either of them. Should the Contractor not attend, or neglect or omit to send such agent, then the measurement made by the Engineer-in-Charge or approved by him shall be taken to be the correct measurement of the work. For the purpose of measuring such permanent work as it to be measured by records and drawings. The Engineer-in-Charge's representative shall prepare records and drawings month by month of such work and the Contractor, as and when called upon to do so in writing, shall, within fourteen days, attend to examine and agree such records and drawings with the Engineer-in-Charge's Representative and shall sign the same when so agreed. If the Contractor does not so attend to examine and agree such records and drawings, they shall be taken to be correct. If, after examination of such records and drawings, the contractor does not agree with the same or does not sign the same as agreed, they shall nevertheless be taken to be correct, unless the Contractor shall, within five (5) days of such examination, lodge with the Engineer-in-Charge's representative for decision by the Engineer-in-Charge, notice in writing of the respects in which such records and drawings are claimed by him to be incorrect.</p>
Clause- 54	<p>Method of Measurement</p> <p>The Works shall be measured net, notwithstanding any general or local custom, except where otherwise specifically described or prescribed in the Contract. The contractor shall be made necessary arrangements for verification of well assembly, depth of drilling, water level and discharge.</p>

Clause-55

Key Personnel

- a. The contractor shall employ the key personnel named in the Schedule of Key Personnel and provide all necessary superintendence during execution of the work and as long thereafter as may be necessary for proper fulfilling of the obligations under the contract. The contractor shall immediately after receiving letter of award of the tender, intimate in writing to the Engineer the name, qualifications, experience, age, address and other particulars along with certificates, of the Site Manager to be the In-charge of the work. The Engineer shall within 15 days of receipt of such communication intimate in writing his approval or otherwise of site manager of the Contractor. Any such approval may at any time be withdrawn and in case of such withdrawal the contractor shall appoint another such Site Manager according to the provisions of this Clause.
- b. Decision of the Engineer shall be final and binding on the contractor in this respect. Such site manager shall be appointed by the contractor soon after receipt of the approval from Engineer and shall be available at site at start of work. The Site Manager shall on receiving reasonable notice from the Engineer present himself to the Engineer and / or at the site of work, as required, to take instructions.
- c. In case the Site Manager of the contractor does not discharge his duties satisfactorily, the Engineer shall have full powers to suspend the work and contractor shall be held responsible for the delay so caused to the work.
- d. The contractor shall provide and employ on the site only such technical persons as are skilled and experienced in their respective fields and such supervisory staff as are competent to give proper supervision. The contractor shall provide and employ semi-skilled/unskilled labour as is necessary for proper and timely execution of the work.

CERTIFICATES AND PAYMENTS

Clause-56

CERTIFICATES AND PAYMENTS

PAYMENT TERMS FOR DRILLING & CONSTRUCTION OF PIEZOMETERS

A. Payment on Account:

The Contractor will complete the individual site in all respect and handover the site to WAPCOS and GMDA, Haryana.

For Payment on account, bill shall be prepared on the basis of actual work executed, measured and acceptance of work executed. Any payment shall be released on back to back basis after receipt of payment from GMDA, Haryana.

The Nominated Contractor (Executing Agency) acknowledges that under the present Contract, WAPCOS is only working as intermediary between GMDA, Haryana being Principal

Employer/Client and Contractor. Thus the Contractor unconditionally acknowledges that the payments under the present Contract shall be made proportionately by WAPCOS only on back to back basis i.e., after 21 days subject to receipt of payment from GMDA, Haryana being Principal Employer/Client. The Contractor also unconditionally agree that in the event the payment or part thereof, under the present Contract is not received from GMDA, Haryana (Principal Employer/Client), then WAPCOS &/or any of its Employee/Officer shall not be responsible to pay any amount to Contractor. The said condition shall supersede any and all other conditions of Contract between the parties."

B. Final Account:

- a. The final bill shall be submitted within two month of physical completion of the work or within two month of the date of the final certificate of completion furnished by the Engineer-in- Charge whichever is later.
- b. The contractor shall make no further claims after submission of the final bill and these shall be deemed to have been waived and extinguished.

C. Security Deposit (Retention Money)

Deduction towards Retention Money/Security Deposit @ 05% (Five Percent) of each bill (running/final) shall be made as under:

- a) In respect of drilling of Piezometer component, security deposit @05% of each running bill and final bill shall be deducted, which shall be refunded after expiry of maintenance period prescribed for drilling work component.
- b) In respect of supply installation and commissioning of Digital Water Level Recorder Component, security deposit @05% of each running bill and final bill shall be deducted, which shall be refunded after expiry of maintenance period prescribed for supply installation and commissioning of Digital Water Level Recorder Component.

D. Income Tax;

Deduction towards income tax shall be made from every interim payment certified by Engineer-in-Charge in terms of Income Tax rules as in force from time to time as per Government of India.

E. Deduction towards TCS on GST

Deduction towards GST (TDS) shall be made from every interim payment certified/final bill by Engineer-in-Charge in terms of GST rules as in force from time to time as per Government of India. GST will be reimbursed after submission of documentary proof. The

GST as applicable shall be charged as per prevailing norms of the Government of India.

G. Labour Cess:

Contractor is required to pay the Cess @ 1 % of the cost of construction work as per Government Norms. Labour cess @ 1% shall be deducted on the bills, payable to the contractor for the construction works covered under this contract.

PAYMENT TERMS FOR SUPPLY, INTALLATION, COMMISIONING & MAINTENANACE OF DWLR

Payment shall be made in Indian Rupees in the following manner:

PAYMENT TERMS FOR SUPPLY, INTALLATION, COMMISIONING & MAINTENANACE OF DWLR

Payment shall be made in Indian Rupees in the following manner:

The Supplier shall be paid 40% (as per clause **Disbursement of Payment**) of the Contract Price excluding cost of Item Sr. no. 6 and excluding GST as per Price and Completion Schedule- Related Services , and the balance 60% (as per clause **Disbursement of Payment**) of the Contract Price excluding cost of Item Sr. no. 6 and excluding GST as per Price and Completion Schedule- Related Services , for O&M and data communication over the next five years @ 12% per year which include 5 year period of onsite warranty as mentioned below

Disbursement of Payment shall be as under:-

i) 40% of the Contract Price excluding cost for item Sr. No. 6 and excluding GST Price and Completion Schedule - Related Services shall be paid as per follows;

- 20% of Contract price excluding cost of Item Sr. no. 6 and excluding GST, against Supply of Goods shall be released on pro-rata basis after 30 days of the successful Delivery and installation of all the instruments/ Equipment as per Schedule of Requirements and its final acceptance.
- 20% of Contract Price excluding cost of Item Sr. no. 6 and excluding GST will be paid on pro-rata basis after 30 days of testing, commissioning and final acceptance.
- Payment against item under Sr. no. 6 of PRICE and Completion Schedule - Related Services, charged in invoice excluding GST, shall be released on pro-rata basis subject to satisfactory completion of this item as per technical specification.

ii) 60% of the Contract Price excluding cost for item Sr. No. 6 and excluding GST Price and Completion Schedule - Related Services but including replacement of parts if any and seamless data communication, here onwards referred as maintenance charges over the balance 05(five) years (5 years of warranty period) shall be paid as per follows;

- 12% per Year to be paid on Half Yearly basis (6% at every six month) inclusive of GST payable on Supply of related services. The Conditions (applicable for this payment) shall be governed by Annexure I: Service Level Conditions.

iii) Payment of GST will be against valid Invoice as per GST Act & Rules and submission of GST Registration Certificate along with declaration that GST Registration is valid and all liabilities towards GST have been discharged by the vendor. GST amount will be reimbursed after 30 days of submission of valid Invoice and all required documents and declaration by vendor.

(iv) For all the payments to be made, against Bank guarantees, the bank guarantee shall be issued by a Scheduled Commercial Indian Bank or a foreign bank located in India. The guarantees issued by other banks should be confirmed by a Scheduled Commercial Indian Bank or a foreign bank operating in India.

v) For all the payments to be made, against Bank guarantees, the bank guarantee shall be issued by a Scheduled Commercial Indian Bank or a foreign bank located in India in the format enclosed at Section X. The guarantees issued by other banks should be confirmed by a Scheduled Commercial Indian Bank or a foreign bank operating in India.

The bidder shall indicate in the Price Schedules specifying all items prices shown therein including the unit prices and total prices of the goods and related services along with GST or any duties and taxes applicable against the schedule of requirements. GST if leviable shall be paid applicable. Any statutory variation shall be paid on submission of documentary evidence. Bidders shall be required to quote HSN code and applicable tax rates. "GST" means all four Acts CGST, SGST, UTGST, IGST and any other regulations by Government in relation to GST and rules thereto.

The Associate/Sub-consultant/Sub-Contractor acknowledges that under the present Contract/ Agreement/Work Order/Arrangement, WAPCOS is only working as intermediary between GMDA being Principal Employer/Client and Associate/Sub-consultant/Sub-Contractor. Thus the Associate/Sub-consultant/Sub-Contractor unconditionally acknowledges that the payments under the present Contract/Agreement/Work Order/ Arrangement shall be made proportionately by WAPCOS only on back to back basis i.e. after 21 days subject to receipt of payment from GMDA being Principal Employer/Client. The Associate/Sub-consultant/Sub-Contractor also unconditionally agree that in the event the payment or part thereof, under the present Contract/Agreement/ Work Order/Arrangement is not received from GMDA (Principal Employer/Client), then WAPCOS &/or any of its Employee/Officer shall not

	<p>be responsible to pay any amount to Associate/Sub-consultant/Sub-Contractor. The said condition shall supersede any and all other conditions of Contract/Agreement/Work Order/Arrangement between the parties.</p>
Clause-57	<p>Security Deposit Security deposit shall be released after expiry of maintenance period as prescribed below from the date of issuance of completion certificate.</p> <p>a) In respect of Drilling of Piezometer Component: In these conditions, the expression “Period of Maintenance” shall mean a period of 12 months after commissioning of last well and issue of completion certificate whichever is later.</p> <p>b) In respect of Supply, Installation & Commissioning of Digital Water Level Recorder Component: In these conditions, the expression “Period of Maintenance” shall mean a period of five years after Supply, Installation & Commissioning of last Digital Water Level Recorder and issue of completion certificate whichever is later.</p>
Clause-58	<p>Approval only by Maintenance Certificate No certificate other than the Maintenance Certificate referred to in Clause-59 hereof shall be deemed to constitute approval of the works.</p>
Clause-59	<p>Maintenance Certificate</p> <p>i) The Contract shall not be considered as completed until a Maintenance Certificate shall have been signed by the Engineer-in-Charge stating that the Works have been completed and maintained to his satisfaction. The Maintenance Certificate shall be given by the Engineer-in-Charge within 28 (twenty eight) days after the expiration of the Period of Contract, or, if different periods of maintenance shall become applicable to different sections or parts of the Works, the expiration of the latest such period, or as soon thereafter as any works ordered during such period, pursuant to Clause-46 and 47 hereof, shall have been completed to the satisfaction of the Engineer-in-Charge and full effect shall be given to this Clause, notwithstanding any previous entry on the Works or the taking possession, working or using thereof or any part thereof by WAPCOS. Provided always that the issue of the Maintenance Certificate shall not be a condition precedent to payment to the Contractor of the retention money in accordance with the conditions set out in Clause-60 hereof.</p> <p>ii) Cessation or WAPCOS's Liability'</p> <p>WAPCOS shall not be liable to the Contractor for any matter or thing arising out of or in connection with Contract or execution of the Works unless the Contractor shall have made a claim in writing in respect thereof before the giving of the Maintenance Certificate under this Clause.</p> <p>iii) Unfulfilled Obligations</p> <p>Notwithstanding the issue of Maintenance Certificate, the Contractor and, subject to sub Clause (ii) of this Clause, WAPCOS shall remain</p>

	<p>liable for the fulfillment of any obligation incurred under the provisions of the Contract prior to the issue of the Maintenance Certificate which remains unperformed at the time such Certificate is issued and, for the purposes of determining the nature and extent of any such obligation, the Contract shall be deemed to remain in force between the parties hereto.</p>
--	---

REMEDIES AND POWERS

<p>Clause –60</p>	<p>Remedies and Powers</p> <p>i) Default of Contractor</p> <p>If the Contractor shall become bankrupt, or have a receiving order made against him, or shall present his petition in bankruptcy, or shall make an arrangement with or assignment in favor of his creditors, or shall agree to carry out the Contract under a committee of inspection of his creditors or, being a corporation, shall go into liquidation (other than a voluntary liquidation for the purposes of amalgamation or reconstruction), or if the Contractor shall assign the Contract, without the consent in writing of WAPCOS first obtained, or shall have an execution levied on his goods, or if the Engineer-in-Charge shall certify in writing that, in his opinion, the Contractor;</p> <ul style="list-style-type: none"> a) has abandoned the Contract, or b) without reasonable excuse has failed to commence the Works or has suspended the progress of the Works for fifteen days after receiving, from the Engineer-in-Charge, written notice to proceed or c) has failed to remove materials from the site or to pull down and replace work for twenty eight days after receiving from the Engineer-in-Charge's written notice that the said materials or work had been condemned and rejected by the Engineer-in-Charge under these conditions, or d) despite previous warnings by the Engineer-in-Charge in writing, is not executing the Works in accordance with the Contract, or is persistently or flagrantly neglecting to carry out his obligations under the Contract, or e) has, to the detriment of good workmanship, or in defiance of the Engineer -in- Charge's instruction to the contrary, sub-let any part of the Contract; <p>then the Engineer-in-Charge may, after giving seven day's notice in writing to the Contractor, enter upon the Site Works and expel the Contractor, from the entire Works or part thereof, without thereby voiding the Contract or releasing the Contractor from any of his obligations or liabilities under the Contract, or affecting the rights and powers conferred on WAPCOS or the Engineer-in-</p>
--------------------------	---

	<p>Charge by the Contract, and may itself complete the entire Work or part thereof as the case may be or may employ any other Contractor to complete the Works. WAPCOS or such other Contractor may use for such completion so much of the Constructional Plant, Temporary works and materials, which have been deemed to be reserved exclusively for the execution of the works, under the provisions of the Contract, as he or they may think proper, and WAPCOS may, at any time, sell any of the said Equipment, Temporary works and unused materials and apply the proceeds of sales in or towards the satisfaction of any sums due or which may become due to him from the Contractor under the Contract.</p> <p>ii) Valuation at Date of Forfeiture</p> <p>The Engineer-in-Charge shall, as soon as may be practicable after any such entry and expulsion by WAPCOS, fix and determine ex-party, or by or after reference to the parties or after such investigation or enquiries as he may think fit to make or institute, and shall certify what amount, if any, had at the time of such entry and expulsion been reasonably earned by or would reasonably accrue to the Contractor in respect of work actually done by him under the Contract and the value of any of the said unused or partially used materials, any Equipment and any Temporary Works.</p> <p>iii) Payment after Forfeiture</p> <p>If WAPCOS shall enter and expel the Contractor under this Clause, it shall not be liable to pay to the Contractor any money on account of the Contract until the expiration of the Period of Maintenance and thereafter until the costs of execution and maintenance, damages for delay in completion, if any, and all other expenses incurred by WAPCOS have been ascertained and the amount thereof certified by the Engineer-in-Charge. The Contractor shall then be entitled to receive only such sum or sums, if any, as the Engineer-in-Charge may certify would have been payable to him upon due completion by him after deducting the said amount. If such amount shall exceed the sum which would have been payable to the Contractor on due completion by him, then the Contractor shall, upon demand, pay to WAPCOS the amount of such excess and it shall be deemed a debt due by the Contractor to WAPCOS and shall be recoverable accordingly.</p> <p>In the event of the above course being adopted by the Engineer-in-Charge, the Contractor shall have no claim to compensation for any loss sustained by him by reason of having purchased or procured any equipment, material or entered into an agreements or made any advances on account or with a view to the execution of the Works or the performance of the Contract.</p>
<p>Clause –61</p>	<p>Urgent Repairs If, by reasons of any accident, or failure, or other event occurring to in or in</p>

	<p>connection with the Works or any part thereof, either during the execution of the Works or during the Period of Maintenance, any remedial or other work or repair shall, in the opinion of the Engineer-in-Charge or the Engineer-in-Charge's Representative, be urgently necessary for the safety of the Works and the Contractor is unable or unwilling at once to do such Work or repair, WAPCOS may employ and pay other persons to carry out such work or repair as the Engineer-in-Charge or the Engineer-in-Charge's Representative may consider necessary. If the work or repair so done by WAPCOS is work which, in the opinion of the Engineer-in-Charge, the Contractor was liable to do at his own expense under the Contract, all expenses properly incurred by WAPCOS in so doing shall be recoverable from the Contractor by WAPCOS, or may be deducted by WAPCOS from any money due or which may become due to the Contractor. Provided always that Engineer-in-Charge or the Engineer-in-Charge's Representative, as the case may be, shall, as soon after the occurrence of any such emergency as may be reasonably practicable notify the Contractor thereof in writing.</p>
--	--

SPECIAL RISKS/ TERMINATION

<p>Clause-62</p>	<p>Special Risks/ Termination of Contract</p> <p>i) Special Risks</p> <p>The special risks are war, hostilities (whether war be declared or not), invasion, act of foreign enemies, the nuclear risks.</p> <p>ii) Termination of the Contract</p> <p>If, during the currency of the Contract any of the Special Risks mentioned herein above which, whether financially or otherwise, materially affects the execution of the Works, the Contractor shall unless and until the Contract is terminated under the provisions of this Clause, continue to use his best endeavours to complete the execution of the Works.</p> <p>Provided always that WAPCOS shall be entitled at any time after occurrence of such Special Risks to terminate the Contract by giving written notice to the Contractor and, upon such notice being given, this Contract shall, except as to the rights of the parties under this Clause and to the operation of Clause-67 hereof, terminate, but without prejudice to the rights of either party in respect of any antecedent breach thereof.</p> <p>iii) Removal of Equipment on Termination</p> <p>If the Contract shall be terminated under the provisions of the last preceding sub-clause, the Contractor shall, with all reasonable dispatch, remove from the Site all equipment and shall give similar facilities to his sub-Contractors to do so.</p> <p>Provided always that against any payments due from WAPCOS under this sub clause, WAPCOS shall be entitled to be credited with any</p>
-------------------------	--

	<p>outstanding balances due from the Contractor for advances in respect of equipment and materials and any other sums which at the date of termination were recoverable by WAPCOS from the Contractor under the terms of the Contract.</p>
<p>FRUSTRATION</p>	
<p>Clause –63</p>	<p>Payment in Event of Frustration If a war, or other circumstances outside the control of both parties, arises after the Contract is made so that either party is prevented from fulfilling its Contractual obligations, or under the law governing the Contract, the parties are released from further performance, then the sum payable by WAPCOS to the Contractor in respect of the work executed shall be the same as that which would have been payable under Clause-62 hereof if the Contract had been terminated under the provisions of Clause-62 hereof.</p>
<p>Clause – 64</p>	<p>Solvency Certificate Bidder should have a solvency equal to 40% of estimated cost. The bidder must submitted original Solvency certificate to WAPCOS office before due date. Bidder must provide the name, designation, power of attorney with valid official email id and contact number of issuing Bank Authority of solvency certificate. Solvency Certificate must have been issued after the date of publication of NIT & be addressed to the tendering authority quoting the name of the work. The Solvency Certificate should not be dated beyond the last date of submission of the bids.</p>
<p>NOTICES</p>	
<p>Clause - 65</p>	<p>Notices</p> <p>i) Service of Notices on Contractor.</p> <p style="padding-left: 40px;">All certificates, notices or written orders to be given by the Engineer-in-Charge to the Contractor under the terms of the Contract shall be served either by sending by post or delivering the same to the Contractor's office on Site or his principal place of business, or such other address as the Contractor shall nominate for this purpose.</p> <p>ii) Service of Notices on WAPCOS or Engineer-in-Charge</p> <p style="padding-left: 40px;">All notices to be given to WAPCOS or to the Engineer-in-Charge under the terms of the Contract shall be served by sending by post or delivering the same to the respective addresses given below:</p> <p>WAPCOS Limited 9 C, 9th Floor, Hansalaya Building, Barakhamba Road, New Delhi, Delhi-110001 E-mail: gwrldm@wapcos.co.in</p> <p>iii) Change of Address Either party may change a nominated address to another address by prior written notice to the other party.</p>

DEFAULT OF WAPCOS

Clause – 66	Default of WAPCOS <ul style="list-style-type: none">i) In the event of WAPCOS failing to pay to the Contractor the amount due under any certificate of the Engineer-in-Charge within 45 (forty five) days after the same shall have become due under the terms of the Contract, subject to any deduction that WAPCOS is entitled to make under the Contract, the Contractor shall be entitled to issue a notice to the Engineer-in-Charge stating that he shall be terminating his Works after thirty days from the issue of such notice, for the reasons stated therein. However, if within the said period of thirty days, the Engineer-in-Charge notifies the Contractor that the reason stated in the notice of the Contractor are not valid or that the alleged event of default of WAPCOS has been remedied or no longer exists. Then the contractor shall not be entitled to terminate the Contract.ii) If the Contractor becomes entitled to terminate the Contract in terms of sub clause (i) of this Clause, after expiry of the notice of thirty days, he may, notwithstanding hereof, remove from the Site all equipment brought by him.iii) In the event of such termination, WAPCOS shall be under the same obligations to the Contractor in regard to payment as if the Contract had been terminated under the provisions in Clause 65 hereof, but in addition to the payments specified in Clause-57 (iv) hereof, WAPCOS shall pay to the Contractor the amount of any loss or damage to the Contractor arising out of or in connection with or by consequence of such termination.
CHANGES IN COSTS AND LEGISLATION	
Clause – 67	Increase or Decrease of Costs <p>The rate quoted by the Contractor shall remain valid for a period till the completion of work.</p>
Clause-68	Taxation <ul style="list-style-type: none">i) The price bid by the contractor shall include all duties, levies etc. (except GST), that may be levied according to the laws and regulations.ii) The Contractor's staff, personnel and labor will be liable to pay personnel income tax in India in the respect of such of their salaries and wages as are chargeable under the laws and regulations for the time being in force, and the contractor shall perform such duties in regard to such deduction thereof as may be imposed on him by such laws and regulations.
Clause-69	Bribery and Collusion <p>i) WAPCOS shall be entitled to terminate the contract and recover from the contractor the amount of any loss resulting from such termination if the contractor shall have offered or given to any person any consideration of any kind as an inducement or reward for doing, forbearing to do, any action in relation to obtaining, or in the execution of the Contract or any other Contract with WAPCOS, or for showing favour to any person in relation to the Contract or any other Contract with WAPCOS, or if any of the like acts shall have been done by any</p>

	<p>person employed by the Contractor or acting on his behalf (whether with or without the knowledge of the Contractor), or if the Contractor shall have come to any agreement with another Contractor or number of Contractors whereby an agreed quotation or estimate shall be offered as a bid to WAPCOS by any one or more Contractor(s).</p> <p>ii) In the event of such termination, the Contractor shall:</p> <p>a) Proceed as provided in Clause 62 (iii) hereof:</p> <p>b) Be paid by WAPCOS as provided in clause 62(iv) hereof, provided that any loss referred to in sub clause (i) of this clause shall first be deducted.</p>
Clause-70	<p>Termination of Contract for WAPCOS's Convenience</p> <p>i) WAPCOS shall be entitled to terminate this Contract at any time for WAPCOS's convenience after giving sixty days prior notice to the Contractor, with a copy to the Engineer-in-Charge.</p> <p>ii) In the event of such termination the Contractor shall:</p> <p>a) Proceed as provided in the sub-clause -62 thereof and;</p> <p>b) be paid by WAPCOS as provided in sub-clause-62(iv) hereof.</p>
Clause-71	<p>Contractor's near relatives Employed on the Project</p> <p>The Contractor shall intimate WAPCOS before submitting his bid whether any of his near relative is posted on the project as Manager/Deputy Manager or as an Officer in any capacity between the grades of Dy. Chief Geologist and Assistant Engineer (both inclusive) in WAPCOS. He shall also intimate the name of persons who are working with him in any capacity or are subsequently by him and who are near relatives to any officer in WAPCOS. Any breach of this condition by the Contractor will render him liable to be removed from the list of Contractors of WAPCOS and his work may be terminated without any compensation whatsoever.</p>
Clause-72	<p>Retired Officers taking up Contract</p> <p>No official employed on Engineering or Administrative duties in an Engineering Department of the Government of India is allowed to work as/for a Contractor for a period of his retirement from service without the previous permission of WAPCOS. This Contract is liable to be cancelled if either the Contractor or any of his employees is found, at any time, to be such a person who had not obtained the permission of WAPCOS as aforesaid, before submission of the bid or engagement in the Contractor's service as the case may be.</p>
Clause-73	<p>Settlement of Disputes</p> <p>Any dispute, controversy or claims arising out of or relating to this Agreement or the breach, termination or invalidity thereof, shall be settled through following mechanism.</p> <p>a). Firstly the aggrieved party shall write a letter to the other party detailing its grievances and calling upon the other party to amicably resolve the dispute by convening a joint meeting. Accordingly, the parties as per their convenience shall jointly convene the said meeting(s), wherein minutes of the said meeting(s) shall be prepared and countersigned by all the parties. It is mandatory to prepare minutes of meetings and to be countersigned by all the parties,</p>

	<p>irrespective of the outcome of the said meeting(s).</p> <p>b). In the event the parties fails to resolve the dispute within 21 days then depending on the position of case, either the purchaser or supplier shall give notice to another party of its intention to commence arbitration.</p> <p>c). It is only upon failure of the pre litigation mediation mechanism with Delhi High Court Mediation Cell, then the aggrieved party shall mandatory resort to resolution of dispute through arbitration of a sole arbitrator. The appointing authority of sole arbitrator is CMD, WAPCOS limited, to which neither of the parties have any objection nor they shall ever object.</p> <p>d). Subject to parties agreeing otherwise, the Arbitration proceedings shall be conducted in accordance with the provisions of the Indian Arbitration and Conciliation Act, 1996.(amended as on date).</p> <p>e). It is also acknowledged and accepted that WAPCOS is only working as Intermediary between the Associate/Sub-Consultant/Sub-Contractor and the Principal Employer/Client, thus in the event, any dispute arises under the present agreement and referred to Arbitration for adjudication, then subject to corresponding clause in the Contract/Agreement/Work Order/Arrangement between Principal Employer/Client & WAPCOS, Principal Employer/Client shall also be made party to the said Arbitration proceedings. Also, the award including costs if any passed against WAPCOS and costs incurred in the proceedings shall be the sole responsibility of Principal Employer/Client. The said clause if found inapplicable, even then the other terms of the Arbitration Clause shall survive and shall be acted upon.</p> <p>f). The place/seat of arbitration shall be the place from where the contract has been issued and any award whether interim or final shall be made, and shall be deemed for all purposes between the parties to be made, in the place from where the contract has been issued. The arbitral procedure shall be conducted in English language and any award or awards shall be rendered in English. The procedural law of the arbitration shall be Indian Law. The award of the arbitrator shall be final and conclusive and binding upon the Parties.</p> <p>g). The Contract and any dispute or claim arising out of or in connection with it or its subject matter or formation (including non-contractual disputes or claims) shall be governed by and construed in accordance with the laws of India and the Parties submit to sole & exclusive jurisdiction of courts at Delhi.</p>
--	--

GUARANTEE	
Clause-74	<p>GUARANTEE</p> <ol style="list-style-type: none"> 1. Calibration and validation of the installed system shall continue during the entire Warranty period on half yearly basis. 2. The remote stations shall store the data for at least one year. 3. The data would be measured four times a day with an interval of 6 hours and would be transmitted once in a day.

	<ol style="list-style-type: none">4. Security of the equipment's installed at remote locations shall be responsibility of the bidder during the entire project period (5 years).5. Supply a detailed operation and maintenance manual for each appropriate unit of supplied Goods.6. Although all accessories and fixtures required for installation of the equipment & their specifications have been specified in technical specifications however, bidder shall ensure the satisfactory performance & functioning of DWLR system complete, for this if any accessory or items are required that shall be provided by bidder, the cost towards that is deemed to be included in the cost tendered by the bidder, no extra cost shall be paid to the bidder on this account.7. Also bidder will be responsible to provide protection like canopy etc. to DWLR instrumental all Existing observation bore wells. The cost of Installation, Testing and Commissioning of DWLR station shall to be inclusive these protection measures cost.8. The typical schematic civil work drawing for installation of Digital Water Level Recorder (DWLRs) is attached for reference. However bidder has to provide the detailed civil work/fabrication drawing for installation arrangement as per the site condition and for which approval of Purchaser is required.9. The supplier will be responsible for all Civil Works involved in the execution of the contract. Security of installed equipment's including theft and vandalism will be the responsibility of the Bidder during the entire project period (5 years)10. Ensure that all software licenses and maintenance agreements are in the name of Purchaser and should seek full support and updates for such software for the duration of the warranty period and Annual Maintenance Services Period. All the software original licenses should be valid for the design life of the system, that is 10 years from date of commissioning.11. Blue tooth Facility for Data Downloading from DWLR station, and Provide Mobile App is in bidder scope.12. If deemed necessary, the bidders will have to give presentation of the proposed DWLRs including the field demonstration, as per request and location decided by the employer.13. If Bore Well Dried out, reinstallation is charged free of cost by the bidder.14. Every 6 months Re-calibration of Instrument done by bidder and report submit to Representative Officer.15. Recurring and non recurring expenditure (for 5 years) in Bidder
--	---

	<p>Scope</p> <p>16. O&M period for 5 years will be start after commissioning of all DWLR instruments.</p> <p>17. Agency will deploy one Project Engineer 24*7 along with laptop at GMDA office for entire project Period.</p>
Clause 75	<p>SERVICE LEVEL CONDITIONS</p> <p>The bidder is fully responsible to keep the system functional during installation, warranty period. The bidder should take sue-moto action to repair any faulty instrument and should not wait for a complaint from purchaser to initiate action.</p>
	<p>DEFINITIONS</p>
REMOTE SITE	<p>Remote site is the site at remote location where Digital water level recorder (DWLR) systems are installed. The Remote site DWLR generally installed within the Piezometers' headwork, dug wells (open wells), Ground / Surface water level monitoring site or any combination of these sites</p>
DATA CENTRE	<p>Data center is there spective server where data is expected to be received. In case of GSM & GPRS based telemetry, the data center is the server installed in state data center for receiving GSM & GPRS transmission.</p>
INVALID DATA	<p>A data would be considered invalid if</p> <p>a) The value recorded / transmitted is beyond permissible limit for that variable. The valid permissible upper limits and lower limits for each monitoring variable for each site would be provided to bidder by the purchaser.</p> <p>b) If the sensor value recorded / transmitted is absurd values or sudden variation in the value (may be within the specified limits) which is not in-line with the actual physical parameter. (e.g. If the Water level sensor recorded / transmitted value is showing absurd sudden variation of 2mts (beyond the limits of rate of change of sensor value) with respective to the previous measurement interval, then this data is invalid data).</p> <p>c) If the sensor value recorded / transmitted is having frequent / periodic gaps then the data will be considered as invalid data.</p> <p>d) If the sensor value recorded / transmitted is remain constant, even if there is variation in the physical parameters. (e.g. If the Water level recorded / transmitted value is showing constant / fix value even</p>

	<p>there is variation in the water level, then this data is invalid data)</p> <p>e) If the sensor value recorded / transmitted is not in line with the value of co-located automatic / manual observation of the same sensor parameter.</p>
FAILED DATA TRANSMISSION	<p>For each remote station, each scheduled transmission (for all variables including battery voltage) would consist of one data transmission. A data transmission would be considered failed if any of the following conditions are true</p> <ul style="list-style-type: none"> • There is no transmission of data from remote site • Data is transmitted from remote site but not received at state data centre/ e-SWIS. • Data is recorded in data logger but not transmitted • Data is not recorded by data logger • Battery voltage not transmitted • Only battery voltage is transmitted without any actual data from sensors • Data is transmitted but data values are invalid.
FAULTY STATION	<p>A station would be considered faulty if:</p> <ul style="list-style-type: none"> • In case of DWLR data received at State Data Center, if there is ≥ 8 data measurement (≥ 2 transmission cycles / 2 days) are failed / invalid data receptions.
FAULTY DATA CENTRE	<p>A Data Centre shall be treated as Faulty if</p> <ul style="list-style-type: none"> • Vital Hardware Equipment's installed by bidder at State Data Centre are not functioning properly • Bidder has failed to pay the communication charges (SIM, internet, GSM/GPRS etc.) & system is not in function due to unpaid communication charges.
MAXIMUM RESPONSE TIME FOR REPAIR (MRTR)	<ul style="list-style-type: none"> • The MRTR for Remote station would be 7 days • The MRTR for Data Centre would be 2 days
MINIMUM TIME BETWEEN REPAIRS PER STATION	<ul style="list-style-type: none"> • The minimum time between repairs is six months. If a station went faulty for reasons attributed to bidder and availed of MRTR once, it would not be eligible to avail the free repair period within payment period (six months)
PAYMENT FOR DATA RECEPTION	<p>The payment would be released proportion to data received at the Data Center. A table below presents the percentage of data reception and corresponding payment.</p>

Percentage of data received	Payment to be made to vendor
90-100%	100% of (6% of contract price to be paid six monthly as per GCC clause no. 56)
80-89.99 %	90% of (6% of contract price to be paid six monthly as per GCC clause no. 56)
70-79.99 %	80 % of (6% of contract price to be paid six monthly as per GCC clause no. 56)
60-69.99 %	70 % of (6% of contract price to be paid six monthly as per GCC clause no. 56)
50- 59.99%	60% of (6% of contract price to be paid six monthly as per GCC clause no. 56)
40- 49.99%	40%of (6% of contract price to be paid six monthly as per GCC clause no. 56)
30-39.99%	25% of (6% of contract price to be paid six monthly as per GCC clause no. 56)
Below 30%	NIL of (6% of contract price to be paid six monthly as per GCC clause no. 56)

The calculations for data reception percentage are as below

Data reception percentage for each station =

$$[1 - (\text{No of Failed transmissions} / \text{No of transmissions expected})] * 100$$

Data reception percentage for each station is calculated for payment period (six months) Number of transmissions expected is calculated based on transmission cycle. For 6-hourly transmission cycle, if there are 182 days in six months period,

The no. of expected transmissions = 182 (days) * 4 (transmissions per day) for a given station. If a station went faulty during payment period of six months and availed of free time of MRTR (7 days), the 7 days period would be subtracted from no. of expected transmissions. For example, if a station went faulty and payment period is for 182 days, the number of transmissions expected would be calculated as:

Number of transmissions expected = (182-7) * 4; here 7 days time to repair. However, this deduction would be allowed only once in six months period for any given station. Where n is number of remote stations

In case the percentage of data reception is below 50% continuously for 3 months, the Engineer- in-charge may initiate termination process as per GCC clause no. 70.

Clause 76 **Joint Venture**

	<ul style="list-style-type: none"> i. Separate identity/name shall be given to the Joint Venture firm. ii. Not more than two partners are allowed to form a Joint Venture firm. iii. A member of JV firm shall not be permitted to participate either in individual capacity or as a member of another JV firm in the same tender. iv. The tender form shall be submitted only in the name of the JV firm and not in the name of any constituent member. v. Normally EMD shall be submitted only in the name of the JV and not in the name of constituent member. However, in exceptional cases EMD in the name of lead partner can be accepted subject to submission of specific request letter from lead partner stating the reasons for not submitting the EMD in the name of JV and giving written confirmation from the JV partners to the effect that the EMD submitted by the lead partner may be deemed as EMD submitted by JV firm. vi. The members of joint venture must be carried out similar nature of work specified scope of work under ITB Clause-1.2.10. vii. The constitution of the JV firm shall not be allowed to be modified after submission of the tender bid by the JV firm except when modification becomes inevitable due to succession laws etc. and in any case the minimum eligibility criteria should not get vitiated. In any case the Lead Member should continue to be the Lead Member of the JV firm. Failure to observe this requirement would render the offer invalid. viii. Similarly, after the contract is awarded, the constitution of JV firm shall not be allowed to be altered during the currency of contract except when modification become inevitable due to succession laws etc and in any case the minimum eligibility criteria should not get vitiated. Failure to observe this stipulation shall be deemed to be breach of contract with all consequential penal action as per contract conditions. ix. On award of contract to a JV firm, a single Performance Guarantee shall be required to be submitted by the JV firm as per tender conditions. All the Guarantees like Performance Guarantee, Bank Guarantee for Mobilization advance, machinery Advance etc. shall be accepted only in the name of the JV firm and no splitting of guarantee amongst the members of the JV firm shall be permitted. x. Joint and several liability – The members of the JV firm to which the contract is awarded, shall be jointly and severally liable to the Employer for execution of the project in accordance with General condition, Special conditions, Additional condition and technical specification of the contract. The JV members shall also be liable jointly and severally for the loss, damages caused to the country during the course of execution of the contract or due to non-execution of the contract or part thereof. xi. Duration of the Joint Venture Agreement – It shall be valid during the entire currency of the contract including the period of extension if any and the maintenance period after the work is completed. xii. All Joint Venture partners should comply with GOI-Guidelines
--	---

	<p>regarding entity/ies registered in India and/or incorporated/established under any law in force in India.</p> <p>xiii. Authorized Member - Joint Venture members shall authorize one of the members on behalf of the Joint Venture firm to deal with the tender, sign the agreement or enter into contract in respect of the said tender, to receive payment, to witness joint measurement of work done, to sign measurement books and similar such action in respect of the said tender/contract. All notices /correspondences with respect to the contract would be sent only to this authorized members of the JV firm.</p> <p>xiv. No member of the Joint Venture firm shall have the right to assign or transfer the interest right or liability in the contract without the written consent of the other members and that of the employer in respect of the said tender/contract.</p> <p>xv. Documents to be enclosed by the JV firm along with the tender. In case one or more of the members of the JV firm is/are partnership firm(s), following documents shall be submitted:</p> <ul style="list-style-type: none"> a) Notary certified copy of the Partnership Deed, b) Consent of all the partners to enter into the Joint Venture Agreement on a stamp paper of appropriate value (in original). c) Power Attorney (duly registered as per prevailing law) in favour of one of the partners to sign the MOU and JV Agreement on behalf of the partners and create liability against the firm. <p>xvi. All the members of the JV shall certify that they are not been black listed or debarred any Govt./Private organization.</p> <p>B. Consortium:</p> <ul style="list-style-type: none"> i. Not more than two partners are allowed to form a Consortium. ii. A member of Consortium shall not be permitted to participate either in individual capacity or as a member of another Consortium in the same tender. iii. The tender form shall be submitted only in the name of the lead partner and not in the name of any constituent member. iv. EMD shall be submitted only in the name of the lead partner and not in the name of constituent member. v. The members of consortium must be carried out similar nature of work specified scope of work and should be registered contractor of any Central or State Government Department/Public Sector Undertaking. vi. On award of contract to a consortium, a single Performance Guarantee shall be required to be submitted by the consortium as per tender conditions. All the Guarantees like Performance Guarantee, Bank Guarantee for Mobilization advance shall be accepted only in the name of the lead partner and no splitting of guarantee amongst the members of the consortium shall be permitted.
--	---

	<p>vii. Joint and several liability –The members of the consortium to which the contract is awarded, shall be jointly and severally liable to the Employer for execution of the project in accordance with General condition, Special conditions, Additional condition and technical specification of the contract. The consortium members shall also be liable jointly and severally for the loss, damages caused to the country during the course of execution of the contract or due to non-execution of the contract or part thereof.</p> <p>viii. All consortium partners should comply with GOI-Guidelines regarding entity/ies registered in India and/or incorporated/established under any law in force in India.</p> <p>ix. Authorized Member - Consortium shall authorize to lead partner on behalf of the consortium to deal with the tender, sign the agreement or enter into contract in respect of the said tender, to receive payment, to witness joint measurement of work done, to sign measurement books and similar such action in respect of the said tender/contract. All notices /correspondences with respect to the contract would be sent only to this lead partner of the consortium. This authorization shall be evidence by submitting a power of attorney signed by legally authorized signatories of all partners.</p> <p>x. Member having majority share in the consortium shall be nominated as lead partner.</p> <p>xi. No member of the consortium shall have the right to assign or transfer the interest right or liability in the contract without the written consent of the employer in respect of the said tender/contract.</p> <p>xii. Documents to be enclosed by the consortium along with the tender. Following documents shall be submitted: (a) Consent of all the partners to enter into the consortium on a stamp paper of appropriate value (in original). (b) Power Attorney (duly registered as per prevailing law) in favour of lead partner to sign the MOU and Agreement on behalf of the consortium.</p> <p>xiii. All the members of the consortium shall certify that they are not been black listed or debarred by any Govt. / Private organization.</p>

Additional Conditions of Contract

CHAPTER- III
ADDITIONAL CONDITIONS OF CONTRACT

CONTENTS

CLAUSE NO.	TITLE OF CLAUSE
1.	Arrangement by Contractor

CHAPTER -III

ADDITIONAL CONDITIONS OF CONTRACT

1. Arrangement by Contractor	<p>1.1 All equipments, tools, plant and labour, but not limited to the following, required for the successful completion of work shall be arranged by Contractor at his cost:</p> <ul style="list-style-type: none">(i) Required DTH Rigs/ Combination Rigs/Rotary Rigs along with all accessories.(ii) Air compressor, Pumping test units, Pumping test units and all other accessories.(iii) Arsenic Test Field Kit(iv) Digital water meter recorder for pumping test(v) Any other equipment, tools & plants and accessories required for successful completion of the work.(vi) POL, suitable size of bits, drilling rods, bentonite mud and other consumable items required for drilling operation.(vii) Bail plug.(viii) Electrode.(ix) Diesel operated welding set.(x) Suitable pump and diesel generating set and measuring device for time, discharge (orifice method) and water level recorder (steel tape) for pumping test at each well site.(xi) For checking the verticality of well, necessary arrangement of plummet which is suspended through a thin wire from tripod with winch.(xii) Arrangements for transportation / storage of water for construction of wells.(xiii) Arrangements for transportation / storage of equipment & construction material in the mentioned area.(xiv) All temporary camp facilities/accommodation for his manpower at site. <p>1.2 Contractor shall quote his rates as per bill of quantities.</p> <p>1.3 The Contractor shall be fully responsible for any failure/collapse of the well during drilling/reaming operation due to breaking/jamming of drilling bits/rods inside the hole, improper well casing/screen connection, improper assembling lowering, defective gravel packing. Under such situation where the length of the already drilling has to be abandoned, no payment shall be made and Contractor shall have no claim whatsoever for such failure.</p> <p>1.4 In case of brake down, repairing or any other reason of nonfunctioning drilling rig will only be allowed for one day, onwards that rig must be replaced.</p> <p>1.5 If at any stage during the development or commissioning of the well, it is observed that the well is not functioning properly as per the</p>
-------------------------------------	---

	<p>technical requirement the contractor at his own cost shall rectify the defect including replacement of any material at his own cost. In case the defects so observed during development/commissioning are not/cannot be rectified and the well has to be abandoned, a new well in near vicinity shall have to be constructed by the Contractor at his own cost.</p> <p>1.6 Site accomodation consisting of basic emenities including lighting, drinking water, sanitation arrangement shall be provide to WAPCOS/GMDA, HARYANA officials during execution of works and for conducting pumping test at each well site. The contractor will arrange to shift from site to site, WAPCOS field staff with his Site accomodation, by contractor transport. Contractor will provide well maintained two vehicles, as inspection vehicle to the WAPCOS till the completion of work along with driver, fuel, POL etc. at contractor cost. However, if contractor fails to provide above facilities to WAPCOS/GMDA, HARYANA officials, an amount equal to 2% of contract price shall be recovered from the contractor’s payment.</p> <p>1.7 The contractor should follow guidelines of honourable Supreme Court of India in order to avoid incident of falling of children in to well. Well to be Fenced properly till protection box is installed.</p>
<p>2. Penalty for non-performance</p>	<p>If the service provider has not corrected a Defect within the time specified in the Procuring Entity’s notice, a penalty for Lack of performance will be paid by the service provider. The amount to be paid will be calculated as a percentage of the cost of having the Defect corrected, assessed as per Contract Clauses.</p>
<p>3. Make in India</p>	<p>Successful bidder is to comply with the Public Procurement (Preference of Make in India), Order 2020 dated 16.09.2020 as amended upto date, while executing the contract.</p>

Technical Specifications

CHAPTER -IV
TECHNICAL SPECIFICATIONS AND DRAWINGS

TABLE OF CONTENTS

S. No.	TITLE OF CLAUSE
A.	Technical specifications for drilling, construction and pumping test of Piezometers/ Wells
B.	Supply, Commissioning and Installation of DWLR
C.	Details of Tentative Locations

CHAPTER –IV

TECHNICAL SPECIFICATIONS

A. **Drilling, construction & pumping test of Piezometers / Wells**

1.0 Dimension of borehole and wells:

Piezometers Wells: The dia of borehole/ pilot hole for particular type of wells shall be of specific measurement. The depth wise specific dia of each type of well is mentioned in Bill of Quantity.

2.0 Well depth:

The depth of wells upto 60-130 mbgl

3.0 Thickness of overburden (For Hard Rock):

The overburden (surface soil) depends on the type of local geology present at the site. The average overburden thickness will be about 50 m which shall be drilled with suitable size of bit (Roller/ drag/ button) with suitable MS casing 6" dia pipe (dia and thickness as per BOQ) shall be installed by the contractor upto the recommended depth during drilling operation.

4.0 Pipes for Well Assembly:

The pipes shall be as per IS code mentioned in BOQ. The length of pipes (Plain and Screen) will be decided by WAPCOS Site-in-Charge and which shall be as per technical requirement at site.

5.0 Drilling & Geophysical Logging Operation:

- a) It shall be preferable to use DTH-cum-Direct-rotary rig/Rotary rig for the drilling operation for hard/soft rocks. However, contractor can use any other suitable (eg.Odex or Combination) type of rig for completing the work successfully. The capacity of the drilling rig should be in conformity to the general specification.
All the equipment, plant, tools for carrying out drilling operation for Exploratory and Observation wells construction shall be in good working conditions.
- b) Representative geological formation samples at regular interval of 3m shall be collected during drilling and stored in sample box duly labeled. Based on this, litho-log will be prepared by the geologist from contractor side and handed over in Barrier bags/reusable retail plastic bags/Biodegradable bags to Engineer-in-Charge/GMDA, HARYANA before finalizing the well assembly. Sample box should be of solid wood or metal frame material. Numbers of Sample Box should be equivalent to the numbers of Rigs and one in addition. (eg. For 3 Drilling Rigs, number of Sample Box should be 3+1=4).
- c) The drilling time log shall be maintained by the Contractor and given to Engineer-in-Charge as per given format.

- d) The choice of drilling shall be based on type of drilling mentioned in the BOQ. Contractor shall deploy the type of rig of sufficient capacity.
- e) The Digital Geophysical Logging at selected boreholes shall be carried out by the Contractor and provide the data to Engineer-in-Charge/ Site-in-Charge for the finalization of Well Assembly. The Log with required information of prominent potential zones & tentative well assembly shall be provided by the Contractor to Engineer-in-Charge/ Site-in-Charge.

6.0 Preparation of Well assembly, Lowering, Gravel Packing & Clay Packing:

- i) Electrical logging or gamma-ray Logging or any type of recommended logging will be conducted by the experience geophysicist from contractor side for confirming accurate depth and thickness of various lithological units at each well site under supervision of WAPCOS Site-in-Charge. The zone tests (if required) will be conducted using packer technique to detect chemical quality, where it is required. The drilling time log will be maintained by the Contractor and given to WAPCOS Site-in-Charge.
- ii) A recommended length of casing pipe should be left above ground level using clamps. A pair of clamps made of 75 cm x 15 cm MS plate of 9 mm thick should be provided and fixed around the casing with proper nuts and bolts which is finally reinforced in the cement concrete. The well should be provided with well cap and protection box with locks (as per BOQ).
- iii) Jointing of casing pipes: The ERW MS plain to plain pipe should be first jointed by welding around the circumference and then three stripes of 38 mm wide 125 mm long and 7.1 mm thickness be equally spaced around the joint and welded, For U-Pvs pipe should be join with proper suitable strip.
- iv) The entire well assembly consisting of casing pipe should be lowered at same time by suitable method as per recommended by Engineer-in-Charge.
- v) The welding rods of make Modi/Adore or standard make may be used.
- vi) The reducer of recommended dia and thickness will be arranged and added by welding at the end of bottom of housing pipe and to the top of the assembly pipe by the contractor.
- vii) Bail plug should be kept at the bottom of the assembly and length will be mentioned in the assembly recommendation from WAPCOS.
- viii) The entire well assembly consisting of housing pipe and screen/plain pipe will be lowered at same time by suitable method.
- ix) The pipes should be of beveled end.
- x) **Gravel Packing:** Gravel packing shall be carried through out the recommended depth range as per proper method recommended by Engineer-in-Charge/ Site-in-Charge. The annular space between well assembly and drilled bore hole will be properly shrouded with suitable pea-gravel size by adoption of reverse fluid circulation method to the depth. If necessary, the proper packing of gravel may be ensured by running air compressor for about ½ to 1 hour. The quantity of pea-gravel may vary depending on the depth of borehole. In case of thick mud available in borehole, it should be thinned by flowing fresh water after lowering well assembly and before gravel shrouding. The materials for gravel packing in the wells should have the following characteristics:
 - i) It should be cleaned properly.
 - ii) Use of weathered gravel material should be avoided and not allowed.
 - iii) The grains of gravel should be smooth, round to sub-rounded and uniform in size.
 - iv) Flat particles should be avoided and not allowed.
 - v) It should be hard (hardness), insoluble and particles of shale, anhydrite and gypsum will not be used.

- vi) The size of pea-gravel should be as per Bill of Quantity.
- vii) The well assembly should be washed with clean water immediately after gravel packing to remove excess of drilling mud present.

Note: It should be ensure that the gravel is completely packed in the annular space as per the assembly recommendation.

- xi) Clay packing shall be carried through out the recommended depth range as per proper method recommended by Engineer-in-Charge/ Site-in-Charge.
- xii) **Alignment and verticality of Well:** Well should be vertical and straight. The alignment and verticality of well will be checked by plummet which is suspended through a thin wire from tripod with winch. The verticality test needs to be carried out in presence of site Engineer-in-Charge by the drilling unit. To ensure verticality of tube well the guides may be used with assembly pipe at the time of well assembly lowering.

7.0 Well Development:

The well should be developed by air compressor and over pumping unit to ensure sand free discharge and optimal yield.

a) Development by Air Compressor

During, development by air compressor, the operation shall be carried out as under:

- 1) Development by compressor need to be carried out by using suitable air pressure as per site requirement.
- 2) Suitable size Eduction pipe need to be used as discharge pipe and suitable air line should be used for air supply.
- 3) The development should commence from the top of aquifer tapped and should be carried out towards bottom and the development operation should be repeated again from top to bottom.
- 4) The development with Air compressor for exploratory well as well as observation well should be carried out till the water becomes mud/sand free in Exploratory Wells/ Observation Wells. Any changes during the development recommended by WAPCOS Site-in-Charge should be considered immediately by the Contractor.

b) Development by Over-pumping Unit (Pre-Pumping)

Suitable submersible pump of required discharge range with suitable lift-up capacity need to be lowered for development of Exploratory bore holes to ensure sand free discharge. The recommendation for discharge will be shared with contractor after development of well. Alternatively, turbine pump of suitable capacity can also be used for development by Pumping test unit. The Development of Exploratory well by over pumping will be carried out as per Bill of Quantity till the water becomes clear free from sand/ Silt and clay etc.

All the equipment including POL & Labour required for carrying out tests but not limited to the following shall be arranged by the Contractor at his own cost:

- i) A suitable pump and prime mover (since power is not available at the well site).
- ii) Measuring devices for time, discharge and V-Notch orifice method water level recorder (Digital water meter recorder /steel tape engraved).

- iii) 25 mm airline needed to be lowered in the test well as well as observation well up to required depth.

10.0 Collection and Analysis of Water Samples:

The contractor will collect water samples as per Bill of Quantities for further chemical analysis. The numbers of samples should be as per mentioned in the BOQ for both type of wells. The sample should be collected in the Laboratory approved sample bottles (as mentioned in BOQ).

Collected water samples should be gone through NABL approved labs only for Basic, Heavy etc. analysis. The type of analysis is given in Bill of Quantities.

11.0 Well Completion:

Cement Concrete Platform:

A cement concrete platform (As mentioned in the figure) will be constructed around the casing at the ground surface. A MS cap (As shown in figure) is to be welded as cap on the top of the Exploratory Wells.

Protecting Box and Display Board:

After the completion of well in respects described above, the contractor shall install Display Board and Protection Box as described in the Drawings given in Figure.

Restoration of Drilling Site: Contractor shall restore site, remove the cutting materials, level the undulations and clear it as it was before.

12.0 Measurement Book (Computerized):

Measurement books of each site is to be prepared and submitted by Contractor site officials. This should be done before the corresponding bill is submitted to the Division Office for payment. The contractor shall submit two spare copies of such computerized MB's for the purpose of reference and records. The contractor shall also submit to the WAPCOS separately his computerized Abstract of Cost and the bill based on these measurements, duly bound, and its pages machine numbered along with two spare copies of the "bill. Thereafter, this bill will be processed by the Division Office and allotted a number as per the computerized record in the same way as done for the measurement book meant for measurements. The contractor shall, without extra charge, provide all assistance with every appliance,

labour and other things necessary for checking of measurements/levels by the Engineer-in- Charge or his representative.

Note:

1. All cutting jobs of pipes etc. will be carried by gas cutter and not by electric current at site.
2. M.S. Electric welding rod of standard quality of suitable size should be used for welding for perfect homogenous joint.

3. The Sounding of top of packed gravel and cement sealing depth position must be ascertained by measuring correctly with 4mm dia. Sounding steel wire rope wound on a properly made rotating stand.
4. Well diagrams to follow the construction works are given below.

13.0 Basic Data Report: The contractor is required to prepare the basic data report (BDR) for all the wells as per the format provided in the tender and instructions given in the Bill of Quantity. The BDR for each of the well shall be submitted to WAPCOS in soft as well as hard copy (two Copies).

Site wise and Well wise Photographs and Videos of all activities in soft copy should be submitted to WAPCOS Head Office in a 1 TB Hard Disk.

B. Supply, Commissioning and Installation of DWLR

The supplier shall be required to provide all of the following material / services for implementation of Real time ground water level data monitoring System to be installed in the Piezometers of Ground Water Department in the State of Haryana. The scope of the work would essentially involve

1. Complete Supply, Installation and Commissioning of Digital Water Level Recorders (DWLR) and telemetry system in the identified piezometers including arrangements for Protection box of prescribed size, fencing and security arrangements including associated civil works, sensors, data logger, software, hardware and ancillaries' equipment, etc.
2. Technical design, supply, installation, testing, commissioning of the Digital Water Level Recorder (DWLR) for the real time ground water level data collection network and establish data communications using GSM & GPRS telemetry between the remote DWLR stations and State NHP Data Centre at GMDA, HR through Cloud server maintained by supplier with API interface and later through the e-SWIS/ e- GEMS/NHP Software. This includes, but is not limited to acquiring service, and maintaining all aspects of the service during the warranty period as well as the Comprehensive maintenance period.
3. Testing the data acquisition and data communication system using GSM/GPRS between the Cloud server and the data center / central facility at NHP HR. The SIM card shall be supplied by the bidder and the availability of Cloud services shall be the responsibility of the supplier. Data transmission charges would be borne by bidder during O&M period.
4. Establish a GSM & GPRS receiving system along with all required arrangement at Cloud server (maintained by supplier) to collect GSM & GPRS data from DWLR station network. This shall include a High Speed uninterrupted internet connection, Static IP, FTP Server with adequate firewall & antivirus protection that will support the seamless transfer of DWLR data stream. And required all acquiring hardware and software, software licenses, installation, configuration. No data processing software has to be provided by the bidder at state data center.
5. Establish communication between remote DWLR stations with GSM & GPRS receiving system along with all required arrangement at Cloud server to collect GSM & GPRS data from DWLR station network. Bidder shall make necessary arrangement for configuration of Cloud Server with adequate firewall & antivirus protection that will support the seamless transfer of DWLR data

from Cloud server to State NHP Data Centre through API interface. And required all acquiring hardware and software, software licenses, installation, configuration. Data processing software has to be provided by the bidder at state datacentre. GW Data thus obtained should also be available on cloud. Cloud server should be located in India and should be as per GUI guideline. All Data transmission charges during O&M period will be borne by the bidder.

6. Perform on-site assembly, start-up of the supplied goods.
7. Complete commissioning integration, testing & organization of the whole system.
8. Provide operation & maintenance services during five (5) years comprehensive warranty period which shall include all components at the remote stations as well as all newly acquired equipment's in the data center.
9. Provide installation and maintenance reports as required by the Purchaser and any delay is not acceptable in time schedule provided by supplier.
10. Supply detailed operation and maintenance manual for each component in the system and compile Knowledge and working supply type Manual for training purpose (including multimedia training kits).
11. Provide classroom and field training to the sufficient number of GMDA Haryana. Personnel on the DWLR data acquisition system. This includes operation and maintenance procedures. Training will also occur at selected field locations as selected by the Purchaser.
12. A guarantee by the manufacturer that all equipment being provided will be supported for a minimum of ten years after the commissioning of the Digital Water Level Recorder (DWLR) system.
13. Calibration and validation of the installed system shall continue during the entire Warranty period on half yearly basis.
14. The remote stations shall store the data for at least one year.
15. The data would be measured four times a day with an interval of 6 hours and would be transmitted once in a day.
16. Security of the equipment's installed at remote locations shall be responsibility of the bidder during the entire project period (5 years).
17. Supply a detailed operation and maintenance manual for each appropriate unit of supplied Goods.
18. Although all accessories and fixtures required for installation of the equipment & their specifications have been specified in technical specifications however, bidder shall ensure the satisfactory performance & functioning of DWLR system complete, for this if any accessory or items are required that shall be provided by bidder, the cost towards that is deemed to be included in the cost tendered by the bidder, no extra cost shall be paid to the bidder on this account.
19. Also bidder will be responsible to provide protection like canopy etc. to DWLR instrument at all Existing observation bore wells. The cost of Installation, Testing and Commissioning of DWLR station shall to be inclusive these protection measures cost.

20. The typical schematic civil work drawing for installation of Digital Water Level Recorder (DWLRs) is attached for reference. However bidder has to provide the detailed civil work/fabrication drawing for installation arrangement as per the site condition and for which approval of Purchaser is required.
21. The supplier will be responsible for all Civil Works involved in the execution of the contract. Security of installed equipment's including theft and vandalism will be the responsibility of the Bidder during the entire project period (5 years).
22. Ensure that all software licenses and maintenance agreements are in the name of Purchaser and should seek full support and updates for such software for the duration of the warranty period and Annual Maintenance Services Period. All the software original licenses should be valid for the design life of the system, that is 10 years from date of commissioning.
23. Blue tooth Facility for Data Downloading from DWLR station, and Provide Mobile App is in bidder scope.
24. If deemed necessary, the bidders will have to give presentation of the proposed DWLRs including the field demonstration, as per request and location decided by the employer.
25. If Bore Well Dried out, reinstallation is charged free of cost by the bidder.
26. Every 6 months Re-calibration of Instrument done by bidder and report submit to Representative Officer.
27. Recurring and non recurring expenditure (for 5 years) in Bidder Scope
28. O&M period for 5 years will be start after commissioning of all DWLR instruments.
29. Agency will deploy one Project Engineer 24*7 along with laptop at GMDA office for entire project Period.
30. GMDA will assist WAPCOS and Contractor to provide pre-existing wells in proper favourable conditions for the installation of DWLRs.

Summary of Technical Specifications

The Goods and Related Services shall comply with following Technical Specifications and Standards:

(I) Specifications of the DWLR, Pressure Type (GW) with Telemetry System

Feature	Value
Site Conditions	
Ambient Temperature	From 0 to +60 °C

Humidity	5-100 %
Altitude	0-2500 meter
DWLR Water Level Sensor with Temperature Sensor	
Sensor Type	For Pressure Type-Submersible pressure transducer with Non- Vented Pressure Sensor with Barometric Pressure Correction for Individual Sensor.
Measuring Range	For Pressure Type- up to 30 meters, up to 50 meters & up to 70 meters as per site requirement
Installation Depth	The installation depth will be: For Pressure Type- a) 50 ± 10 meters b) 130 ± 10 meters
Dimension	For Pressure Type- Outer diameter of sensor unit: <80mm, (for sensor)
Material	Titanium or other better corrosion resistant material
Ingress Protection	For Pressure Type-IP 68 for Sensor
Overall Accuracy	For Pressure Type-0.2%FSO
Resolution	3 mm or better
Reproducibility	0.1% full scale or better
Long Term Stability	For Pressure Type- 0.1% Full scale and should ensure long term stability without any field calibration requirements except barometric compensation
Temperature Measuring Accuracy	For Pressure Type- 0 to 50°C
Temperature Measuring Accuracy	For Pressure Type- Better than ±0.2°C
Burst pressure	For Pressure Type- >3 times Full scale.
Overload pressure	For Pressure Type- 2 times full scale or better, without effect on calibration.
Minimum audio power	For Pressure Type- Not Applicable

Over voltage protection on supply & sensorwires	Should include lightening, over-voltage and surge protection.
Output	SDI-12, RS-485, 4-20 mA or compatible with data logger. .
Installation	For Pressure Type- The system should be provided with a suspension bracket , Well enclosure /canopy & junction boxes (if required) allowing secure installation within the Piezometers' headwork, including appropriate cable mounting accessories to allow the sensor to be adjusted to the required depth.
Direct Read Sensor Cable	For Pressure Type- The cable shall have following features:
	<ul style="list-style-type: none"> • Strength members for good longitudinal stability of cable • The cable and contacts should be fixed or quickconnect. • Cable screen to be connected to the data logger ground terminal to minimize electrical interference. • A cable suspension bracket allowing the DWLR to be adjusted to the required depth, in a stable and reproducible manner. • Corrosion and moisture free as the equipment has to work under water condition. • Cable should have good flexibility. • Should be of Polyurethane Jacket or better • The electrical wires shall have sufficient conductivity to allow for extension of the cable to up to 200m without degrading accuracy, stability and data communication.
Data logger	
Atmospheric Pressure correction	For Pressure Type- In case of Non-vented pressure sensor, data logger should be applied Atmospheric Pressure correction automatically.
Data Logger Input	For Pressure Type- Level sensor, Temperature sensor
Resolution of measurement	For Pressure Type- 16-bit ADC with +/- 1 LSB accuracy 1 mm or better
Measuring interval	Should be programmed to store data from 1 minute one reading to 24 hours one reading with future start option.
Settling up Time	For Pressure Type- < 30 minutes after submersion.
Recording capacity	Shall store data of at least 1 year
Memory type	Non-volatile flash memory that can store one year of data (with 15- minute logging interval) and expandable up to minimum 1 GB using USB/SD Card

Power supply	Should be equipped with lithium or alkaline battery pack, giving at least 2 years operation (one transmission per day and four measurements per day). Batteries must be replaceable in the field or in local offices of the Implementing Agency or supplier. Replacement batteries must be easily available in India
Battery Voltage Monitoring	Monitoring and transmission of Battery Voltage level
Built in clock	Accurate to ± 1 minute per year
Displayed Time Resolution	1 second
Over-voltage Protection	Should include lightening, over-voltage and surge protection
Protection	For Pressure Type- IP68 with Impact Resistant for Water level sensor IP65 (for data logger) with Impact Resistant
Port for configuration	One serial /USB port for communication with laptop for programming
Ports for telemetry	Port for communication with GSM & GPRS telemetry
Operating System	Windows software for system configuration / communication
Licenses	All required licenses shall be included
Real time clock	Time synchronization facility shall be provided with IST
Accessories	Serial /USB cable and adaptor if required along with all accessories and fixing units etc.
Communication Interface	
Communication Interface	The logger must be capable of connection to a computer via USB 2.0 or better and supply should include the necessary interface cables.
Computer Interface	The Logger must be capable of connection to a computer via USB 2.0/USB 3.0 and supply should include the necessary interface cables.
File Format	The format of the data downloaded by communication interface shall be in standard CSV format (as specified in technical Specifications) which is compatible with e-SWIS/NHP software.
GSM & GPRS Transmitter	
Transmission System	GSM/GPRS/edge-based data transmission system
Frequency range	900 MHz: 824-960 MHz/1800MHz:3000-1880 MHz 4G and better
Performance	Data Reception availability of 95% or better
Communication Direction	Utilize GPRS network for two-way connection with FTP server TCP/IP (INTERNET) connection and SMS

Transmission trigger	Data collection to be triggered by interrogation from Data Center, or by event-based transmission triggered by remote site when active (Not in power saving mode)
Power Saving	Ability to disable interrogation system in order to save power at remote site
Communication Protocol	Data transmission to execute HTTP Post or FTP or MQTT,SMS to transmit data to the Data Center
Accessories	All associated equipment, including Antenna all cables and mounting hardware
Software for Data Logger	
Operating System	Windows software for system configuration, transfer and analysis of data to computer
Version	English language version
License	All required licenses included
General Features	
Battery	The battery should be easy to replace in field, and easily available in the Indian market
Tools	Complete tool kit for installation and routine maintenance
Manuals	Full documentation and maintenance instructions in English

(II) Specifications for Data Services

Bidder is to acquire, manage, and operate a data collection, storage, and dissemination to support the following activities during **5 years (or the closure of NHP, whichever is earlier) warranty period** for DWLRs with telemetry system.

Note: A hardware server/storage system for additional backup shall be provided at State Data Center.

S N o.	Parameter	Functionality requirement
1	Data collection performance	<p>Bidder should ensure seamless data and responsible for</p> <ul style="list-style-type: none"> • Real-time data collection at all DWLR stations & shall ensure seamless data transfer. • Real-time data collection from all data stations. The DWLR should be able to gather water level data for time frequency ranging from 10 seconds to 12 hrs as well as on log mode (time/depth) for specified intervals. Purchaser may request changes in data collection schedule on an as needed basis. • The data from DWLR stations will be transmitted through cloud server to State Data Center (SDC) through API-

		<p>Interface in fall and push mode.</p> <ul style="list-style-type: none"> • From SDC to E-SWIS software through internet. This data will be processed and disseminated via E-SWIS cloud. • The processed data from e-SWIS in the form of reports/bulletins will be transmitted to State Data Centre.
2	Data maintenance	All activities pertaining to installation, data services, Operation & maintenance at the remote DWLR station will be maintained by the bidder during the warranty and maintenance period and will include a log of activities during every station visit.
3	Reports & Bulletins Storage system	Storage of all data, reports & bulletins in the proper manner and easy to access. This data will be backed up in such a way that it is not possible to lose data that has already been stored with the use of mirrored or replicated storage.
4	Help desk	Bidder to operate help desk to respond to queries from the purchaser. Help desk will be able to solve any problems related to data collection, processing, and dissemination to the purchaser. Help desk shall be available from 8am to 6pm, Monday –Sat.

(III) Specifications for Data Transmission System (Telemetry)

1. The transmission system should be tightly integrated with the DWLR system, along with compact remote/field mounted systems consisting of sensor, data logger, modem and antenna
2. The system should be watertight (IP68 for sensor & IP65 for data logger or equivalent or as mentioned in Technical Specifications) and impact resistant.
3. The system should allow easy access into the well for monitoring measurements without removing complete system;
4. System must be power-supplied by standard lithium/alkaline batteries for operation time of at least two years by one set of batteries (one transmission per day, 4 measurements per day) and must be placed in a water resistant (**IP65 or equivalent**) enclosure. The replacement of batteries during five years warranty period would be responsibility of the bidder, at bidder's cost
5. The system must have integrated energy management system using free programmable time slots for measurement and transmission to minimize power consumption;
6. The connectors should be water-tight (**IP68 or equivalent or as mentioned in Technical Specifications**).
7. An alarm notification must be sent by the system via SMS to user defined phone numbers through suitable means of communication for user defined parameters. This includes battery performance (battery voltage).
8. A standard USB /RS-232 communication interface **or as mentioned in Technical Specifications**

should be available for set up and configuration and must be easily accessible.

9. Data logger shall be provided with Atmospheric Pressure sensor at individual station, & Atmospheric Pressure correction shall applied automatically on the raw water level reading from non-vented water level sensor. The details of correction procedure shall be fully documented in user manual. Provision shall be made to view and store the raw and compensated water level data along with atmospheric pressure and Water Temperature data in data logger memory (Applicable for Pressure Type DWLRs)
 10. All measurement and set up options, data download and programming of data logger shall also be done by online session similar to all functions at site by direct connection to a PC
 11. Data download / retrieval from remote DWLR station to central server PC via GSM/GPRS network shall be provided. The data from remote station should be in standard CSV format (as specified in technical Specifications) which is compatible with e-SWIS software
 12. The software should be provided to allow download of data from the DWLR data logger on to a Laptop/hand held devices in the field. The downloaded data shall be in standard CSV format (as specified in technical specifications) which is compatible with e-SWIS/NHP software.
- (IV) Fencing with wire mesh (76mm x 76mm x 12 gauge) shall be provided around each piezometer site as per the drawing and specifications provided.

(V) Transmission of Data format to e-SWIS /NHP software:

The format for GSM & GPRS communication is as specified below

Table below gives the GSM / GPRS data parameters and their identification code format which is required to transmit the data from data logger to FTP server.

FORMAT:

&Station ID, Date and Time, Mobile Number, Battery, Water Temp, Corrected Water Level

Above data string will be ended with New-Line character and a separate data string will be for each measurement cycle.

(a) Example Data Spring:

&738D1E76,07/01/19 00:00,9843556430,13.5,22.3,26.347,456

&738D1E76,07/01/19 06:00,9843556430,13.5,24.5,26.347,456

&738D1E76,07/01/19 12:00,9843556430,13.5,26.8,26.347,456

&738D1E76,07/01/19 18:00,9843556430,13.5,24.3,26.347,456

Sl.No.	Channel no.	Parameter
1.	Station ID	Start of String should be "&" and Eight Characters Station ID provider by bidder
2.	Date and Time	Measurement date and Time in DD/MM/YY HH:MM in IST of the

		measurement cycle
3.	Mobile Number	Mobile no (10 digit) of remote station SIM
4.	Battery	Battery voltage in Volts with 1 right digit at measurement date and time
5.	Water Temp	Water Temperature in °C with 1 right digit at Measurement date and time
6.	Corrected Water Level	Water level after atmospheric pressure compensation in Mts. with 3 right digit at measurement date and time
7	Electrical Conductivity	Electrical Conductivity mS/cm with 3 right digit at measurement date and time

Note:

- If any sensor is not connected then it should transmit '--' characters in place of the sensor value.
- Attached format is indicative, recommended for standardised data acquisition for development of unified Water Information System.

C. TRAINING AND DOCUMENTATION

1. The Bidder is required to provide an extensive training programme for the system. The training set forth in the following paragraphs is a minimum requirement and the bidder should
2. propose any additional training that he considers critical for long term success of the system operations.
3. The Bidder is expected to provide an outline or table indicating the contents of each of the required courses. The table shall describe the specific topics to be covered for each day of the training period.
4. The Bidder is responsible for the salaries of the training instructors and all training materials. The costs of travel, transportation and per diem for the trainees shall be borne by the Purchaser.
5. Training shall be provided by the bidder in several phases. The training shall include both classroom and field trainings and will be continued during all five years. The bidder is required to have DWLR equipment specialists.
6. The Bidder shall provide mandatory trainings as training modules as part of the Tender given as under:

S. No.	Description	Numbers of training	Number of Participants per session
1	User Training Course for senior management. (one day)	3 (1 before/during commissioning and 2 during warranty)	15

2	Operation and Maintenance course (3 days). Course topics will include sensor calibration, data logger configuration, data downloading, data retrieval, collection, compilation, processing, maintenance requirements, and procedures for equipment configuration, installation, site testing and commissioning.	5 (2 before /during commissioning and 3 during warranty)	30
---	---	---	----

7. All aspects of the electrical, instrumentation and telemetry equipment being supplied shall be covered in the courses and full documentation shall be provided. The documentation and kits shall be got approved from Purchaser in advance. The course shall provide detail documentation and shall ensure that the Purchaser's personnel shall be able to modify settings/ parameters without reference back to the Supplier. The places / sites where this training will be decided later by the Purchaser.
8. The training course will take place as decided by the Purchaser. In case of formal training, the Purchaser will provide classroom and other logistics. The Bidder will facilitate the professional and the training material. On-the-job training will be provided by the Bidder in conjunction with the installation of hydro-meteorological stations and during the course of maintenance as required.
9. Training kit containing course material in soft as well as hard copy shall be provided by the Bidder.

D. PREVENTIVE MAINTENANCE

The bidder shall be responsible for operation and maintenance of all stations /components of installations, commissioning, site acceptance and operation tests. All equipment maintenance cost, repairs, replacements and repairs to civil work shall be borne by the bidder during the warranty Period. The scope of O&M support would include all materials and services including major replacement of components, mandatory spare parts required to ensure smooth and sustainable operations of the entire system. The bidder shall provide monthly maintenance reports during the course of maintenance.

The bidder shall supply a Manual specifying all the faults experienced by the system together with an account of how such faults have been rectified. Bidder shall provide the list of mandatory spare parts & shall ensure the availability of sufficient mandatory spare parts in its godown for fulfilling its service obligations during warranty period. The same can be inspected by Engineer-in Charge or its authorized representative.

The bidders shall ensure the following visits at remote site for preventive maintenance. The bidder should take time stamped geo tagged photographs of the equipment during each maintenance visit (either scheduled or unscheduled visit). The photographs should show the condition of equipment before maintenance, during maintenance and after maintenance.

SCHEDULE SHOWING FREQUENCY OF SCHEDULED VISITS FOR ROUTINE AND PREVENTIVE MAINTENANCE

Sl. No.	Station Category	Minimum Annual Preventive Visits	Remarks
1	DWLR stations	2	Every Half year and also on need basis

6 E. Operation & Maintenance (O&M)

1. Bidder shall responsible for Operation of DWLR system and ensure seamless data transfer from remote stations to Cloud through GSM/GPRS network & from Cloud server to E-SWIS software through API interface. And also the processed data from e-SWIS in the form of reports/bulletins will be transmitted to State Data Centre which should be stored proper manner and easy toaccess.
2. Operation and Maintenance shall include free of cost repairs/ replacement of hardware and Software necessary to keep the system functional for the period of five years from Date of Installation.

TECHNICAL RESPONSIVENESS FORM

Bidder shall furnish clause by clause commentary against the laid down technical specification and standards as per the format given below:

(A) Summary of Instructions

1. Particulars of Manufacturer and local agent cum representative are to be given under rows Model andAddress.
2. **All entry boxes in column “Specification and Standards as offered in by Bidder” shall be filled in accurately and comprehensively. Quantitative fields shall be filled in accurately. It is not acceptable to use ‘Yes’, No, Compliant or similar evading words. Following format is designed to help the Bidder to understand the requirements of the equipment being procured. The Bidder must describe in the format how his bid responds to the technical requirements of the equipment. Bidder to note that one or two-word responses (e.g. “Yes”, “No” “will comply” or similar evading words) are normally not sufficient to confirm the responsiveness with the technical requirements, hence elaborate responses are sought from the bidders. In case deviation on the following technical requirements of equipment is not as per the minimum criteria mentioned, the bids may be declared“non-responsive”**
3. Requested materials and information shall be enclosed with the bid and be unambiguously associated with instruments as offered in thebid
4. Negligence to comply with the instructions and requirements as stated above makes the bid liable to berejected.

5. Abbreviations: OD-Outer Diameter; ID-Inner Diameter; FS-Full Scale; Pa-Pascal (unit of pressure), DWLR-Digital Water Level Recorder; DRS-Data Retrieval System; HHT-Hand Held Terminal. DCP- Data collection Platform, AWS- Automatic Weather Station, ARG- Automatic Rain Gauge, AWLR- Automatic Water LevelRecorder
6. Sample interval is the interval at which samples or sensor readings are taken. The recording /measurement interval defines the interval at which the data records are stored in memory. A data record can represent a single sample or the average of a number of samples. In particular the result of the wave suppression filter is a single record representing the average value of a number of samples.

(B) Entries requiring specialattention:

1. The longitudinal properties of the suspension cable affect the accuracy directly. Bidder to specify all factors affecting the longitudinal properties of the suspension cable: e.g. length creeps due to sensor and cable weight (submerged) longitudinal temperature coefficient, uncoiling after installation, expansion/contraction of jack due to temperature and aging, etc.

(C) Bidder shall provide information in the formats givenbelow:

1. Make/ Model/ Local Agent etc.:

Bidder	DWLR make/ model	Water level sensor make/ model		Local Agent
Name / Complete Address/Website/ Email	Model: Manufacturer: Name: Place: Tel: Fax: E-mail: Web:	Model: Manufacturer: Name: Place: Tel: Fax: E-mail: Web:		Name: Address: Tel: Fax: E-mail: Web:

2. Clause by Clause Commentary against laid down technical specifications: Specifications of the DWLR, Pressure Type with telemetry system.

Bidders shall furnish clause by clause commentary against the laid down technical specification and standards as per the format given below:

Name of Goods-its Features	Required Specification and Standards as per Bidding Document	Specification and Standards as offered in by Bidder	Remarks
DWLR water Level sensor (Non-Vented, Submersible Pressure sensor with Temperature sensor) (Bidder should clearly specify the type of offered DWLR system)			
Make :			
Model:			
Type:- DWLR			
Manufacturer Name, address, email, phone, website.			
Site Conditions			
Ambient Temperature	From 0 to 60 degree		
Humidity	5-100 %		
Altitude	0-2500 meter		
Name of Goods-its Features	Required Specification and Standards as per Bidding Document	Specification and Standards as offered in by Bidder	Remarks
Sensor Type	Submersible pressure transducer with Non-Vented Pressure Sensor with Barometric Pressure Correction for Individual Sensor		
Measuring Range	For Pressure Type- up to 30 meters, up to 50 & up to 70 meters as per site requirement		
Installation Depth	The installation depth will be: For Pressure Type- a) 50 ± 10 meters b) 130 ± 10 meters		
Dimension	For Pressure Type- Outer diameter of sensor unit: <80mm, (for sensor)		

Material	stainless Steel (SS-316) or other better corrosion resistant material		
Ingress Protection	For Pressure Type-IP 68 for Sensor		
Overall Accuracy	For Pressure Type- 0.2%FSO		
Resolution	3 mm or better		
Reproducibility	0.1% full scale or better		
Long Term Stability	For Pressure Type- 0.1% Full scale and should ensure long term stability without any field calibration requirements except barometric compensation		
Temperature Measuring Accuracy	For Pressure Type- 0 to 50°C		
Temperature Measuring Accuracy	For Pressure Type- Better than $\pm 0.2^{\circ}\text{C}$		
Burst pressure	For Pressure Type- >3 times Full scale.		
Overload pressure	For Pressure Type- 2 times full scale or better, without effect on calibration.		
Minimum audio power	For Pressure Type- Not Applicable		
Over voltage protection on supply & sensor wires	Should include lightening, over-voltage and surge protection.		
Output	SDI-12, RS-485, 4-20 mA or compatible with data logger. .		
Installation	For Pressure Type- The system should be provided with a suspension bracket , Well enclosure /canopy & junction boxes (if required) allowing secure installation within the Piezometers' headwork, including appropriate cable mounting accessories to allow the sensor to be adjusted to the required depth.		

Direct Read Sensor Cable	For Pressure Type- The cable shall have following features: <ul style="list-style-type: none"> Strength members for good longitudinal stability of cable 		
Name of Goods-its Features	Required Specification and Standards as per Bidding Document	Specification and Standards as offered in by Bidder	Remarks
	<ul style="list-style-type: none"> The cable and contacts should be fixed or quick connect. Cable screen to be connected to the data logger ground terminal to minimize electrical interference. A cable suspension bracket allowing the DWLR to be adjusted to the required depth, in a stable and reproducible manner. Corrosion and moisture free as the equipment has to work under water condition. Cable should have good flexibility. Should be of Polyurethane Jacket or better The electrical wires shall have sufficient conductivity to allow for extension of the cable to up to 200m without degrading accuracy, stability and data communication. 		
Data logger			
Make			
Model			
Manufacturer ,Name, address, email, phone, website, fax			
Atmospheric Pressure correction	For Pressure Type- In case of Non-vented pressure sensor, data logger should be applied Atmospheric Pressure correction automatically		

Name of Goods-its Features	Required Specification and Standards as per Bidding Document	Specification and Standards as offered in by Bidder	Remarks
Data Logger Input	For Pressure Type- Level sensor, Temperature sensor		
Resolution of measurement	For Pressure Type- 16-bit ADC with +/- 1 LSB accuracy 1 mm or better		
Measuring interval	Should be programmed to store data from 1 minute one reading to 24 hours one reading with future start option.		
Settling up Time	For Pressure Type- < 30 minutes after submersion.		
Recording capacity	Shall store data of at least 1 year		
Recording Capacity	Shall store data of at least 1 year		
Memory type	Non-volatile flash memory that can store one year of data (with 15-minute logging interval) and expandable up to minimum 1 GB using USB/SD Card		
Power supply	Should be equipped with lithium or alkaline battery pack, giving at least 2 years operation (one transmission per day and four measurements per day). Batteries must be replaceable in the field or in local offices of the Implementing Agency or supplier. Replacement batteries must be easily available in India		
Battery Voltage Monitoring	Monitoring and transmission of Battery Voltage level		
Built in clock	Accurate to ±1 minute per year		
Displayed Time Resolution	1 second		
Over-voltage Protection	Should include lightening, over-voltage and surge protection		
Protection	For Pressure Type- IP68 with Impact Resistant for Water level sensor		

Name of Goods-its Features	Required Specification and Standards as per Bidding Document	Specification and Standards as offered in by Bidder	Remarks
	IP65 (for data logger) with Impact Resistant		
Port for configuration	One serial /USB port for communication with laptop for programming		
Ports for telemetry	Port for communication with GSM & GPRS telemetry		
Operating System	Windows software for system configuration / communication		
Licenses	All required licenses shall be included		
Real time clock	Time synchronization facility shall be provided with IST		
Accessories	Serial /USB cable and adaptor if required along with all accessories and fixing units etc.		
Communication Interface			
Communication Interface	The logger must be capable of connection to a computer via USB 2.0 or better and supply should include the necessary interface cables.		
Computer Interface	The Logger must be capable of connection to a computer via USB 2.0/USB 3.0 and supply should include the necessary interface cables.		
File Format	The format of the data downloaded by communication interface shall be in standard CSV format (as specified in technical Specifications) which is compatible with e-SWIS software.		
GSM & GPRS Transmitter			
Make			
Model:			
Manufacturer, Name, address, email, phone, website, fax			
Transmission System	GSM/GPRS/edge-based data transmission system		
Frequency range	900 MHz: 824-960 MHz/1800MHz:3000-1880 MHz 4G and better		

Name of Goods-its Features	Required Specification and Standards as per Bidding Document	Specification and Standards as offered in by Bidder	Remarks
Performance	Data Reception availability of 95% or better		
Communication Direction	Utilize GPRS network for two-way connection with FTP server TCP/IP (INTERNET) connection and SMS		
Transmission trigger	Data collection to be triggered by interrogation from Data Center, or by event-based transmission triggered by remote site when active (not in power saving mode)		
Power Saving	Ability to disable interrogation system in order to save power at remote site		
Communication Protocol	Data transmission to execute HTTP Post or MQTT or FTP,SMS to transmit data to the Data Center		
Accessories	All associated equipment, including Antenna all cables and mounting hardware		
Software for Data Logger			
Operating System	Windows software for system configuration, transfer and analysis of data to computer		
Version	English language version		
License	All required licenses included		
General Features			
Battery	The battery should be easy to replace in field, and easily available in the Indian market		
Tools	Complete tool kit for installation and routine maintenance		
Manuals	Full documentation and maintenance instructions in English		
Specifications of Data Acquisition Software(DAS)			
Sl	Required Specification and Standards as per Bidding Document	Specification and Standards as offered in by Bidder	Remarks
1	Data collection performance :		

	<p>Bidder should ensure seamless data and responsible for</p> <ul style="list-style-type: none"> • Real-time data collection at all DWLR stations& shall ensure seamless datatransfer. • Real-time data collection from all data stations. The DWLR should be able to gather water level data for time frequency ranging from 10 seconds to 12 hrs as well as on log mode (time/depth) for specified intervals. Purchaser may request changes in data collection schedule on an as neededbasis. • The data from DWLR stations will be transmitted through GSM/GPRS in the standard CSV format (as specified in technical Specifications) to FTP server at the State Data Center(SDC) • From SDC to E-SWIS software through internet. This data will be processed and disseminated via E- SWIScloud. <p>The processed data from e-SWIS in theform of reports/bulletins will be transmitted to State Data Centre.</p>		
2	<p>Data maintenance :</p> <p>All activities pertaining to installation, data services, Operation & maintenance at the remote DWLR station will be maintained by the bidder during the warranty and maintenance period and will include a log of activities during every station visit.</p>		
3	<p>Reports & Bulletins Storage system: Storage of all data, reports& bulletins in the proper manner and easy to access. This data will be backed up in such a way that it is not possible to lose data that has already been stored with the use of mirrored or replicatedstorage.</p>		
4	<p>Help desk :</p> <p>Bidder to operate help desk to respond to queries from the purchaser. Help desk will be able to solve any problems related to data collection, processing, and dissemination to the purchaser. Help desk shall be available from 8am to6pm, Monday –Sat.</p>		
Sl no.	Required Specification and Standards as per Bidding Document	Specification and Standards as offered in by Bidder	Remarks
B.	Specifications for Data Transmission System (Telemetry)		

1.	The transmission system should be tightly integrated with the DWLR system, along with compact remote/field mounted systems consisting of sensor, data logger, modem and antenna		
2.	The system should be watertight (IP68 for sensor & IP65 for data logger or equivalent or as mentioned in Technical Specifications) and impact resistant.		
3.	The system should allow easy access into the well for monitoring measurements without removing complete system;		
4.	System must be power-supplied by standard lithium/alkaline batteries for operation time of at least two years by one set of batteries (one transmission per day, 4 measurements per day) and must be placed in a water resistant (IP65 or equivalent) enclosure. The replacement of batteries during five years warranty period would be responsibility of the bidder, at bidder's cost		
5.	The system must have integrated energy management system using free programmable time slots for measurement and transmission to minimize power consumption;		
6.	The connectors should be water-tight (IP68 or equivalent or as mentioned in Technical Specifications).		
7.	An alarm notification must be sent by the system via SMS to user defined phone numbers through suitable means of communication for user defined parameters. This includes battery performance (battery voltage).		
8.	A standard USB /RS-232 communication interface or as mentioned in Technical Specifications should be available for set up and configuration and must be easily accessible.		
9	Datalogger shall be provided with Atmospheric Pressure sensor at individual station, & Atmospheric Pressure correction shall be applied automatically on the raw water level reading from non-vented water level sensor. The details of correction procedure shall be fully documented in user manual. Provision shall be made to view and store the raw and compensated water level data along with atmospheric pressure and Water Temperature data in datalogger memory.		
10.	All measurement and set up options, data download and programming of data logger shall also be done by online session similar to all functions at site by direct connection to a PC		

11.	Data download / retrieval from remote DWLR station to central server PC via GSM/GPRS network shall be provided. The data from remote station should be in standard CSV format (as specified in technical Specifications) which is compatible with e-SWIS software		
12.	The software should be provided to allow download of data from the DWLR data logger on to a Laptop/hand held devices in the field. The downloaded data shall be in standard CSV format (as specified in technical specifications) which is compatible with e-SWISsoftware		
C.	Fencing with wire mesh (76mm x 76mm x 12 gauge) shall be provided around each piezometer site as per the drawing and specifications provided.		

Specifications of Cloud Server

SI	Required Specification and Standards as per Bidding Document	Specification and Standards as offered in by Bidder	Remarks
	Cloud Server	<u>Make:</u> <u>Model:</u> <u>Manufacturer Name, address, email, phone, website.</u>	

Ground Water Deptt. , Haryana

Drawing of Fencing on Protection Box

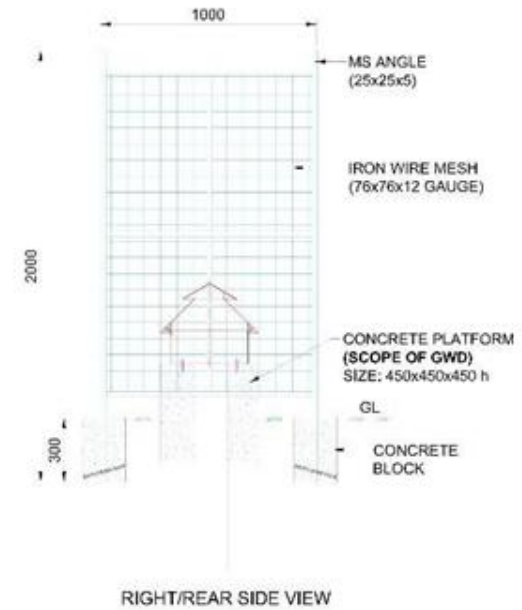
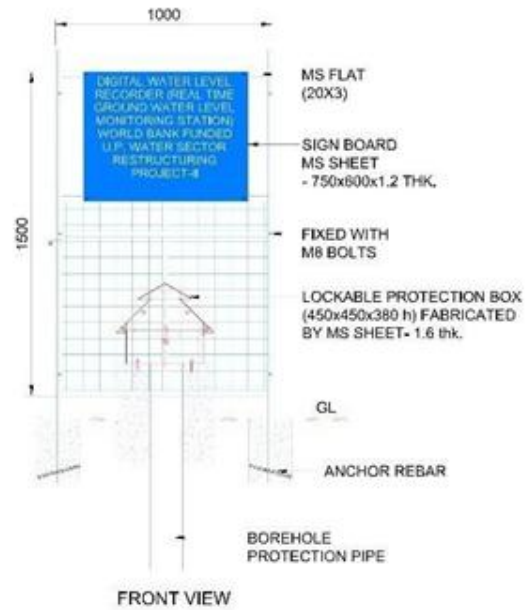
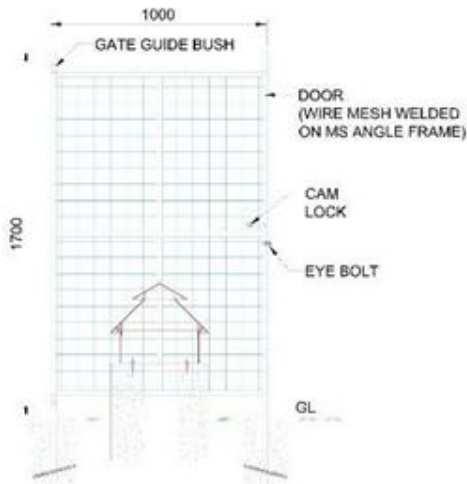
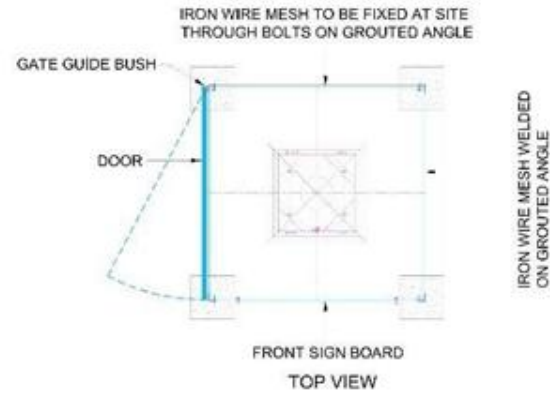

5. INSPECTIONS AND TESTS

The following inspections and tests shall be performed:

General:

1. After manufacture, the supplier shall get each equipment/item of Goods inspected in manufacturer/s works as per approved datasheets and QAP and forward to the Purchaser along with his letter seeking inspect the equipment/item of Goods conform to contract specifications.
2. Upon readiness of the material and receipt of test certificate and calibration certificates, all the equipment shall be jointly inspected and checked by Third Party Inspection Govt. Agency alongwith Purchaser's representative (GMDA Department) and end user representative at manufacture place to carry out quality checks. The Contractor shall inform the Engineer in advance for the factory inspection for material and its fabrication. The inspection and test categories shall be applied prior to delivery of the each equipments,. The production routine test as per relevant IS shall be carried out as a part of acceptance tes.
3. However, the inspection and dispatch clearance by the Purchaser or the waiver thereof shall not prejudice the right of the Purchaser or its consignee to test the equipment/goods on receipt at destination. Upon receipt of the goods at final destination, the Purchaser shall have the right to inspect and/or test the equipment/Goods to confirm their conformity to contractspecifications.
4. If the equipment fails to meet the contract specifications during inspection, whether pre dispatch or upon receipt of at final destination, the supplier shall take immediate steps to remedy the deficiency or replace the defective equipment to ensure that all supplies meet with the specifications specified in thecontract

Inspection and tests prior to shipment of Goods and at final acceptance are as follows:

1. The inspection of the Goods shall be carried out to check whether the Goods are in conformity with the approved technical specifications attached to the contract and shall be in line with the inspection/test procedures laid down in the Technical Specifications and the General Conditions of contract. Following broad test procedure will generally be followed for inspection and testing of instruments. The supplier will dispatch the goods to the ultimate consignee after internal inspection testing along with the supplier's inspection report and manufacturer's warranty certificate. The purchaser will test the equipment after completion of the installation and commissioning at the site of the installation.
 - a. Site Preparation and Installation: The Purchaser will designate the installation sites before the scheduled installation date to allow the Supplier to perform a site inspection before the installation of the DWLRs and associated telemetry system. In case there is a delay in handing over the site by the purchaser, appropriate extension of time shall be granted without imposition of liquidated damages in accordance with the provisions of contract. However, if the extension in time is granted in any circumstances due to any reason by purchaser, the supplier shall not claim such as escalation, price index inflation, any interest amount or any other kind ofclaim.
 - b. For site preparation, the supplier should furnish all details and drawings to the purchaser sufficiently in advance so as to get the works completed before receipt of theequipment.
2. Complete hardware and software as specified in 'List of Goods and Delivery Schedule' Under the

Schedule of Requirement should be supplied, installed and commissioned properly by the supplier prior to commencement of performance tests.

3. The acceptance test will be conducted by the purchaser/their consultant or any other person nominated by the purchaser, at its option. The acceptance will involve trouble-free operation for seven consecutive days. There shall not be any additional charges for carrying out acceptance tests. No malfunction, partial or complete failure of any part of hardware attached to printers, drivers etc. or bugs in the software should occur. All the software should be complete and no missing modules/sections will be allowed. The supplier shall maintain necessary log in respect of the results of the tests to establish to the entire satisfaction of the purchaser, the successful completion of the test specified. An average uptake efficiency of 90% for the duration of test period shall be considered as satisfactory.
4. In the event of the hardware and software failing to pass the acceptance test, a period not exceeding two weeks will be given to rectify the defects and clear the acceptance test, failing which the purchaser reserves the rights to get the equipment replaced by the supplier at no extra cost to the purchaser.
5. DWLRs procured would be subject to the Acceptance Protocol given below.

ACCEPTANCE PROTOCOL

1. General

- a.** The delivery of goods/equipment and software should be in accordance with the contract agreement and the process of delivery will adhere to the following 'Acceptance Protocol'. The Acceptance Protocol shall serve as a formal guidance during delivery of the DWLRs. Its primary goals are twofold.
 - i.** Ascertain the delivery and completeness of all ordered products and related documents.
 - ii.** Check the functioning of the equipment and software in a formal way against the specifications by application of Acceptance Tests. The tests also verify the accuracy and stability of the equipment.
- b.** The Acceptance Protocol shall be executed in close co-operation between the Supplier and the Client.
- c.** Products shall be accepted only if they meet the requirements and are functioning in compliance with the technical specifications, and the related documents are complete and correct. Defective products and any other discrepancies shall have to be replaced/ resolved, within a pre-defined timeframe.

2. Documents

- a. The following documents shall accompany the delivery of the instruments and software:
- i. Administrative and Quality Assurance (QA) documents
 - ii. Test and calibration documents
 - iii. Manuals and Guidelines

All documents shall have identification and references to subject or instrument, date, time, location and officer in charge.

- b. The Acceptance Report lays down the findings and observations during the execution of the Acceptance Protocol and is a formal document to record the acceptance or rejection of any item as covered in the Bid document. Any flaws or findings are to be reported. The forms and checklists filled out during the execution of the Acceptance Protocol are to be enclosed with the Acceptance Report. The Supplier receives a signed copy of the Acceptance Report, which the Supplier can use as proof that the items listed in the report were accepted.
- c. The content of the various documents shall be as follows:

Administrative and QA documents: These QA documents shall include:

- i) Production documents associated with the instruments.
- ii) Type codes, serial numbers and other identification data on, possibly externally procured, sensors and major assemblies, to clearly demarcate the sensors/major assemblies associated with each DWLR.
- iii) Shipping documents indicating instrument/product type, serial number, measuring range, cable length and other similar data.

Test and calibration documents:

- i) A comprehensive Method Statement on the applied calibration and in-factory test procedures shall accompany the bid. The Method Statement should define the test and calibration methods applied on the instruments and the components thereof. The Method Statement shall also include, for each calibrated product, an audit trail to national standards on all instruments and facilities used for testing and calibration. The Audit Trail Report shall associate the calibration of the reference instruments and test equipment to the national calibration standards.
- ii) If the Supplier or Manufacturer is not in a position to deliver an Audit Trail Report to the national standards, the Manufacturer shall explain what the quality standards are and how they are maintained and monitored.
- iii) Conditions during calibration, such as room and/or instrument temperature, equipment and facilities used, shall be included in the calibration and test documents.
- iv) The test and calibration documents shall contain the data generated during calibration and testing, including:

- Calibration data supplied by the Manufacturer of pressure sensor
- Calibration and test data of the data-logger electronics
- Calibration data on overall DWLR calibration, i.e. comprising both pressure sensor and electronics. A table listing applied reference pressures/ measured reference depth versus instrument readings is to be delivered for each sensor and instrument. Furthermore, that table shall also show the test conditions during calibration
- Data on hysteresis test, temperature tests, zero stability/ reading stability test, scale stability test
- Humidity test, in particular for vented gauge pressure sensors
- Temperature cycling of sensor and electronics
- Spray test on enclosure(s), connectors and cables

Manuals and Guidelines

The manuals shall meet the requirements on style and clarity, completeness, preciseness, detail and accessibility. This includes:

- System manual,
- Operation, Maintenance and Service manuals,
- Observation guideline, and
- Training handouts.

Acceptance Tests

1. General

- i. Qualified engineers under responsibility of a test manager shall execute the Acceptance Tests. The progress of the Acceptance Tests would be monitored and supervised by the Client and/or his authorised representative. The Client may have any tests redone or additional tests executed as deemed required based on the results of previous tests conducted. The Client's and/or his authorised representative shall have the right of access to any instrument and may request any data or information at any time. The Supplier has the obligation to deliver requested information without delay; i.e. collected test data and documents must be available at the test site.
- ii. It is important that all activities (what, when, where, who, which instrument, etc.) are annotated and uniquely linked to the individual instruments.
- iii. The Acceptance Tests mainly comprise three levels viz.:
 - **Functional Tests:** The Functional Tests shall verify the proper functioning of the instruments and the associated software. Primary goal is to verify that the instrument performs its functions according to the bid specifications.

- **Accuracy Tests:** The Accuracy Tests shall verify that each individual instrument is functional and operates according to the bid specifications. A number of relatively simple accuracy tests are routinely exercised on the instruments.
- **Overall Test:** The main purpose of the Overall Test is to verify the common features that are identical to all the instruments in a series. Typical components of the Overall Test are:- in-built software functions, materials of the instrument, cables, connectors, etc. Further tests include battery and memory autonomy, details of sensor specifications like temperature effects, hysteresis, long term stability etc.
- The above tests can be executed at any one of the following locations:- Premises of the Manufacturer/Supplier; Premises of the Client; Independent organisation; at Site of installation
 - iv. The charges for testing shall be borne by the Manufacturer/Supplier. The Client and/or his authorised representative may at his cost opt to be present during the performances of the tests.
 - v. If the tests are executed at the Client's premises, the charge for testing shall be borne by the Client and the Supplier shall be responsible for conducting the tests. The bidder in his bid shall indicate the name of independent organisation and the charges for testing. The Client reserves the right to accept the independent organisation and its charges or get the tests done by any other agencies. However, the Supplier would be permitted to be present at these tests.

(Explanatory Note: Test report from manufacturer would be acceptable. In case purchaser desires to test the system from independent agency (ies), testing charges would be borne by purchaser.)
 - vi. The details of these tests are as follows.

Functional Tests: The Functional Tests include: visual inspection, and user tests.

Visual Inspection: Visual inspection includes the following activities.

- i) All items are visually checked for damage, e.g. on cables, sensor and housing.
- ii) Availability of non-removable identification codes and specifications are verified, e.g. serial number, type identification, manufacturer and measuring range.
- iii) Cables have to be marked: each cable is to have an identification code and name.
- iv) Cable connectors shall have their ends marked suitably to indicate the device to which it is to be connected, e.g. PC, HHT, Power Supply etc. Suitable precaution shall be taken so that the connectors are not connected to wrong terminals, i.e. it shall be impossible to connect a power cable to a communication bulkhead socket.

2 User tests

- i) All instruments have to be identical except for measuring range, cable length, identification code and similar aspects. Consequently, there is no need to check the functionality of all systems. It is assumed that the functional compliance with the specifications is tested under the Overall Tests. The objective of the

user test is to detect any malfunction and/or defect. From practical point of view, the user tests can be coupled with other test, e.g. the stability tests.

ii) Basic functions to be tested are:

- Pre-deployment preparation, e.g. setting of clock, erasing of memory, setting data logging parameters, entry of identification data
- Facilities for execution of on-site functional checks
 - Data retrieval and data transfer to PC
 - Battery status and voltage
 - Conversion of retrieved data into ASCII table for application by user's software
 - Simple output test by observing pressure reading while the sensor is immersed in a bucket filled with water (For pressure type) or Simple output test by observing sensor mounted on a pipe of length 2 meter.

Accuracy Tests: The Accuracy tests include:

- accuracy tests on clock, and
- accuracy tests on pressure sensor measurement.

3 Accuracy tests on clock

- i) The clock of the data logger shall be carefully checked against national time, e.g. taking the radio broadcast time beeps as a reference. The data logger clock is set precisely and checked at the start of the individual tests and upon instrument and/or data retrieval. In between, the clock should not be readjusted.
- ii) The clock test shall cover at least 3 days to get sufficient time resolution. The reference clock, e.g. a watch, must be carefully tuned against national time prior to and during the tests. The clock drift, converted to seconds per month (31 days) shall comply with the defined specifications. This test method makes use of the specified time resolution of 1s.

4 Accuracy tests on pressure measurement

- i) **For pressure-** The accuracy test on the pressure sensor is an overall accuracy test covering both the pressure and electronics systems. The pressure tests are to be executed against accurately known reference pressure(s). Pressure can be generated from compressed air (gas) or by submerging the sensor to known depths in water.
- ii) **For Pressure** - Reference pressure may be created via a precision pressure reduction valve from a source of compressed air. A high precision sensor like a Digi Quartz pressure sensor or a Dead Weight Tester can be implemented to quantify the applied pressure. Pressure should be measured in kPa (or mbar).
- iii) When applying the immersion method it is much more difficult to check the instruments because water density affects the reading. Moreover, it is not simple to establish the exact depth of sensor immersion. And especially in narrow wells, while immersing a pressure sensor on its cable into a well, the water level will rise due to the additional volume of the immersed pressure sensor and cable. The water level will gradually fall again, when the well level adjusts again to equilibrium with the ground water level. In order to achieve a high accuracy these effects have to be assessed.

- i) The pressure sensor tests include:
 - Zero stability test (for pressure)
 - Scale test
 - Scale stability test
- v) The pressure sensor tests shall focus on temperature effects on zero, scale and cable length, and in addition to that establish quantitative data on drift of zero, scale and creep of cable length.

(a) Zero stability test

- i) During the zero-test the instruments are in logging mode, say at an interval of 30 minutes, and shall be kept in a separate room where they will not be touched for at least 3 days. The instruments must be dry, i.e. not in a bucket of water, to exclude any water effect on the sensor, and hence, the instrument reading is expected to be 0.0.
- ii) Under this test, each instrument will record its short term zero drift and inherently the effectiveness of the air-pressure compensation method. During the zero-test, the instruments shall be in the same and constant position, vertical or horizontal. The room temperature shall vary over 5 °C or more, e.g. due to daily temperature fluctuation, this to assess temperature effects on the instrument reading. This requirement may affect the choice of venue for the zero-tests. To avoid any adverse temperature strain, no direct sunlight shall fall on the instruments. At the end of the test, the collected data are offloaded from the data logger memory and analysed for zero stability. As the instruments are kept in air and are not touched, the reading shall be stable and not change over time that is not beyond permissible limits.
- iii) Room temperature is to be logged against time, preferably by digital method. In case the DWLR has a built-in temperature sensor, that sensor may be used for temperature logging. The pressure sensors shall not be tested in an air-conditioned room for several reasons. First, temperature fluctuations may be so rapid that the sensor temperature compensation scheme may not be able to cope with it. Moreover, rapid air-pressure fluctuations may not be handled properly by the air-vent system and/or the pressure measurement method. This is to be understood from the perspective that the instruments are designed to operate in wells where changes occur but not rapidly. One or more fans may be operated continuously to minimise temperature gradient across the test room.
- iv) To test the creep and elongation of the electrical cum suspension cable some vertical open space is required, e.g. a stairwell can be used for this purpose. However, it is important that the cable is protected against touch to avoid interference with the measurements. The cable is loaded with some weight to emulate the weight of cable and sensor. The length of cable under tests shall be as long as possible, i.e. 10 m or more, to get the best accuracy of the tests. The lowest point is suspended to about 0.15 m above the floor. The gap between lowest point and floor is monitored against time. Initially readings are taken every 30 minutes for 12 hours, subsequently the reading interval may be increased to 6 hours. The cable test shall be executed during 7 days. Resolution of measurement should be 1 mm or better. The result is to be presented in mm length change per meter suspended cable length. Only one cable is to be tested.

(b) Reading stability test

- i. The test is carried out on a standard calibrated 2m test setup. During the reading stability test the instrument are in logging mode say at an interval of 30 minutes and shall be kept in separate room where they will not be touched for at least 3 days. The instrument and the setup must be dry to exclude water effect on the sensor.
- ii. During the reading stability -test, the instruments shall be in the same and constant position, vertical or horizontal. The room temperature shall vary over 5 °C or more, e.g. due to daily temperature fluctuation, this to assess temperature effects on the instrument reading. This requirement may affect the choice of venue for the zero-tests. To avoid any adverse temperature strain, no direct sunlight shall fall on the instruments. At the end of the test, the collected data are offloaded from the data logger memory and analysed for reading stability. As the instruments are kept in air and are not touched, the reading shall be stable and not change over time that is not beyond permissible limits
- iii. Room temperature is to be logged against time, preferably by digital method. In case the DWLR has a built-in temperature sensor, that sensor may be used for temperature logging. First, temperature fluctuations may be so rapid that the sensor temperature compensation scheme may not be able to cope with it. Moreover, rapid air-pressure fluctuations may not be handled properly by the air-vent system measurement method. This is to be understood from the perspective that the instruments are designed to operate in wells where changes occur but not rapidly. One or more fans may be operated continuously to minimise temperature gradient across the test room..

Scale test: A precisely known pressure is applied on the instrument and the instrument reading is taken. The instrument reading is converted into level or pressure whatever is applicable. The calculated value is compared with the applied value; the difference is regarded as the FS error. In case the specifications of the applied pressure sensor may give reason to doubt the instrument's linearity, then a mid-scale test is to be executed as well.

Scale stability test: Scale stability is tested by subjecting the instrument to the full-scale pressure for at least 24 hours. During the test, the applied pressure/level is to be accurately monitored by taking reference readings either by a reference logger of high accuracy or by manual readings. The accuracy and resolution of the reference measurement must be 1 mm water column or 0.01 k Pa (0.1 mbar).

Overall Test: Part of the Overall Test is also covered under the Functional Tests and Accuracy Tests. The Overall Test comprises testson:

- autonomy
- fitness forenvironment
- functionality
- calibration
- stability
- reproducibility, and
- main power failure

Details of the various tests are as follows.

Autonomy: Two autonomy tests shall be conducted:

- battery capacity versus the power consumption per measurement, and
- memory capacity
 - i) Battery autonomy test: To execute the test, the instrument is set to a fast data collection interval and the capacity, i.e. the number of samples, is established by a continuous process of data collection until the batteries are depleted. The test shall be executed on new batteries. In this context, the batteries are deemed depleted when the instrument stops functioning because the battery voltage watch-dog function detects a too low battery voltage or the normal operation of the instrument stops.
 - ii) Memory capacity verification: The memory is filled at the highest data-recording rate and the volume of collected data is verified against the bid specification. This test could be combined with the battery autonomy test and the samples are taken at a high rate to minimize the test duration.

Fitness for environment:

- iii) Connectors, cable glands, cables and housing must be suitable for the environment of operation, be it submersed, in a well or above the ground. Water ingress can be assessed by visual inspection and / or by insulation measurement. Visual inspection may only reveal ingress of a significant amount of water.
- iv) The insulation measurement is more sensitive, especially for cables, connectors and encapsulated electronics, but requires specialised equipment.

- v) The above-surface components have to be compatible with IP65 standard and shall be tested accordingly by exposing them to a heavy shower for 3 minutes. Subsequently the ingress of water is assessed by opening of the instrument and connectors.
- vi) The submersible components must comply with IP68 standards. To verify this, the instrument shall be suspended in a well for at least one week, to a maximum depth, without affecting the calibration of the pressure sensor and not exceeding 2 times the rated measuring range. Although most pressure sensors can withstand considerably more than 2 times the rated measuring range, there is no need to exceed this. Prior to this test, the zero and scale of the sensor have to be established and verified again upon recovery.

Functionality

- vii) Functionality has to be verified for all requirements for operation of the DWLR and DRS with reference to the bid specifications and the instrument specifications as given by the Manufacturer. Missing functionality shall be reported.
- viii) All (software) functions as stated in the instrument manual(s) and the instrument specifications are tested for correct functioning. Any detected flaws are reported which shall be repaired/rectified by the Manufacturer/Supplier within seven days.

Calibration

- ix) The instrument calibration is checked for compliance with the bid specifications. In particular accuracy, stability, linearity, hysteresis and reproducibility are verified.
- x) **For pressure-** The scale or sensitivity of the complete instrument, including sensor and electronics, is to be checked for at least 11 pressures, equally distributed over the full measuring range. Furthermore, the calibration data as delivered with the instrument are verified for accuracy and consistency with data obtained from the calibration tests. The calibration may be executed by application of accurately known air-pressure or by immersion in a well. The temperature effects on the calibration should also be verified at low, mid and maximum range temperatures.

Note: Prior to execution of immersion tests, the effective position of the sensor membrane relative to the sensor housing is to be assessed and measured, e.g. by execution of a bucket experiment. In this experiment, the sensor is partly immersed in a water filled bucket to a depth where the related reading has changed by several centimetres, relative to the 'in-air' reading. During the test, the position of the water surface on the sensor's body shall be observed and marked accordingly. The 'effective-sensor-zero' lies below the water surface during the test. The position of the effective-sensor-zero is below the above mentioned water-surface mark by the equivalent of the sensor reading expressed in centimetres. The effective-sensor-zero may be close to the sensor membrane but not necessarily coincides with it.

Stability: Stability related to the DWLR is defined as a variation over time of the instrument specifications, whereas the circumstances (and pressure for pressure type) do not vary. Parameters to be checked are:

- zero: offset stability/ reading stability.
- scale: full scale stability
- cable: length (extension/contraction) and creep stability

The methods to assess these stability factors are explained under the section on Accuracy Tests.

Reproducibility:

Pressure type- The sensor reading in air is annotated, subsequently the sensor is immersed to the rated measuring depth, and a stable reading is collected. Then the sensor is recovered to the surface and again a stable reading is taken. This process is repeated 5 times and results are duly annotated. It is important that during the complete test the instrument is kept in the same, vertical position.

Main power failure:

- xi) Some instruments operate on replaceable batteries or even external power and have a built-in back-up facility, usually based on a Lithium battery. It is quite possible that on some instruments the external power supply or the replaceable batteries fail because of total depletion, disconnection, defect on the cable or connector etc. In such an event, the instrument must retain its clock, its program setting and most importantly all the collected data.
- xii) The Functional Tests are executed in conjunction with the stability test. Upon finalising these tests and after successful retrieval of all test data the power is disconnected by removing the main power batteries and/or disconnecting the power cable. The instrument is to be left in that state for at least 24 hours. Then the power shall be connected again and clock, program settings and recorded data are checked for availability and correctness.
- xiii) Instruments with entirely built-in factory replaceable batteries cannot be tested in this way. In such case, the Manufacturer shall provide a technical description of the method applied to avoid loss of clock, program and collected data.

4. Test Execution: Two test programmes are to be executed:

- All Units Test Programme
- Single Unit Test Programme

Prior to execution of the tests, a detailed test script has to be drafted and agreed upon. The test script shall define:

- Test sequence.
- the test conditions and requirements for each test.
- place of the test.
- person(s) responsible for conducting the tests.
- Reporting requirements.
- handling failures and problems.

All Units Test Programme: The All Units Test Programme aims to identify the malfunctioning instruments and those not compliant with the bid specifications. The Functional Tests, the Clock Accuracy Test and the Zero Stability Test/ Reading stability test, must be executed on each instrument. The design of the tests shall be selective and practical and enable execution with simple means, preferably at the Client's premises.

Single Unit Test Programme

- i) A full system shall be tested, that is: pressure sensor electronics, cable, power supply, DRS, software and manuals. The Single Unit Test Programme is a combination of the Functional

Tests, the Accuracy Tests and the Overall Test. The Client shall randomly select an instrument for testing from the instruments delivered. The Single Unit Test Programme can only be started after verification that all documents related to the order/delivery, including manuals, calibration data, QA data etc., are delivered to the Client. Any other unit, for which doubts arise on its compliance with the bid specifications, shall also be tested on the client's request.

- ii) Failing to pass the Single Unit Test Programme results in rejection of the entire delivery until the defective units have been repaired to meet the technical specifications, and such to the satisfaction of the Client.

5. Evaluation of test results:

The test results have to be evaluated and results and conclusion shall be reported. Instruments that do not meet the bid specifications shall be replaced by properly functioning and satisfactorily tested instruments.

6. Post acceptance performance monitoring

- i) After installation and field deployment the instrument performance shall be continuously monitored by taking manual observations, initially at a relatively high rate, e.g. every 3 hours, gradually migrating towards the normal monitoring interval. The level comparisons are required for reference and validation purposes. Manual observations and automatic readings shall be taken at short intervals after each other, in practice the time difference shall be kept to less than 15 minutes. The primary criterion though, is that the manual reading shall be taken before the water level changes more than 1mm.
- ii) Other checks are on functioning of the internal clock, data recording and retrieval, battery discharge, siltation of the sensor, moisture ingress and any development of corrosion.
- iii) The tape used for taking the reference readings shall be of high accuracy, considerably better than the accuracy of the DWLR, only then the performance of the high accuracy instruments can be monitored. However, an accuracy of 1 mm over the full measuring range is enough. Only best quality tapes, e.g. the electric types, come close to this requirement. The tapes shall be checked for accuracy against a precise reference, e.g. over 10 or 20 m on a single stretch. Verification by a standard ruler will not reveal to overall accuracy of a tape. The 'tape verification reference' could be prepared using high accuracy geodetic equipment. A long, straight corridor, or a quiet stretch of road, could accommodate the length reference marks, the accuracy should be 1 mm relative to the reference point (0.000m).

7. Instrument History File

For each instrument, an individual History File shall be opened and maintained (The Instrument history file shall be suppliers' scope.). In the History File the full instrument history and all documents generated shall be stored. This also includes any changes, adaptations, repairs etc. made to the instruments. The products and results of the execution of the Acceptance Protocol shall be included in the Instrument History File. Some document types and entries are listed below:

8. Instrument identification: The instrument identification uniquely defines the instrument particulars.

- Make, vendor, service provider, date of manufacturing, date of delivery
- Instrument make, model and serial number
- Instrument configuration
- Measuring range
- Cable type, length

- Manual version
- Instrument status: e.g. working, under calibration, under repair

9. Functional, Accuracy and Over-all tests: For each of the three test categories, a separate and unambiguous record shall be maintained. The test conditions and results shall be duly recorded. Obviously any failures or irregularities shall be annotated accurately and comprehensively, as well as the actions taken and their results. At least the following data shall be recorded:

- Administrative data: what, when, where, who, which instrument and configuration
- List of tests
- Specifications for each test
- Results of each test
- Failures, actions, conclusions

10. Piezometer well definition: The piezometer well definition is required in order to link the instrument readings to MSL and the hydro-geological properties of the well. The piezometer identification shall have sufficient detail to link it with the hydro-geological data recorded in the project database. The reference point on the piezometer well, as used for the level measurements, shall be unambiguously depicted and its height above MSL defined. The particulars of the local benchmark (name, location, and co-ordinates, height above MSL, etc.) shall be recorded for reference purposes. Following entries are indicative and not conclusive.

- Piezometer: District, name, location, co-ordinates, identification
- Photo
- Elevation relative to MSL
- Description of reference point particulars
- Identification of reference spot on piezometer well
- Local benchmark: district, location, identification, co-ordinates, height above MSL

Deployment: Another part of the history file covers the deployment: installation, servicing, maintenance, data retrieval etc. All facts shall be recorded, (what, when, where, who, which instrument and configuration). The suspended depth of the instrument relative to the reference point shall be annotated. Further, manual water level observations (when, who, level, reference) shall be taken regularly and verified with the instrument records. To allow for an accurate comparison, the time and other particulars of the manual observation shall be recorded. The manual observations shall coincide with the programmed automatic instrument readings. This shall be regularly repeated. Photos showing the mode of installation are very useful.

i) Some of the required particulars are:

- Suspension depth relative to the reference point on the piezometer well
- Recording interval
- Photos of the deployed instrument and piezometer well Following two shall be repeated regularly
- Manual observations, taken concurrently with the automatic measurements
- Observer, date and time of manual reading

ii) The following entries are associated with any changes made to the instruments. Again, the 'what, when, where, who, which instrument and configuration' shall be recorded, for each event:

- Repairs: minor and major repairs and including change of silt filter or battery etc.
- Adaptations: e.g. replacement of EPROM, RTC clock speed adjustment
- Settings: these are the common operational settings such as recording interval, suspension depth and the like.
- Calibration: most likely calibration is executed in a special workshop. Obviously, calibration is a major event and has to be recorded and documented accurately and comprehensively. This implies also the method of calibration, reference instruments used (and including a paper trail to national standards or other proof of calibration cum accuracy), conditions during calibration, officers in charge etc.

11. Acceptance Certificates:

On successful completion of acceptability test, receipt of deliverables etc., and after the purchaser is satisfied with the working of the DWLR system, the acceptance certificate signed by the supplier and the representative of the purchaser will be issued. The date on which such certificate is signed shall be deemed to be the date of successful commissioning of the systems.

FORMATS FOR SUBMISSION OF HYDROGEOLOGICAL DATA

LOGGING DATA

Unique ID	
Location	
Block	
District	
Toposheet Number	
Latitude in Degree Decimal	
Longitude in Degree Decimal	
Site plan and RL(m amsl)	
Date/Year	
Depth Drilled (m bgl)	
Depth Logged (m bgl)	
Bore hole dia.	

Unique ID

Depth range (m bgl)		Thickness (m)	Natural Gamma counts (CPS)	Inferred Lithology
From	To			

Depth range (m bgl)		Thickness (m)	Electrical Log (Ohm-m)		Inferred Lithology
From	To		N64	N16	

Signature and stamp of Authorized signatory

Tentative Assembly Design

Depth range (m bgl)		Thickness (m)	Zones to be Tapped	Potentiality (Very Good/ Good/ Fair)
From	To			

BASIC DATA REPORT

GOVERNMENT OF HARYANA

Faridabad Metropoliton Development Authority

BASIC DATA REPORT OF EXPLORATORY WELL

AT (Name of Village), (Name of block)

District / State

By

Agency

Under overall supervision of

Month/ year

BASIC DATA REPORT OF EXPLORATORY WELL

AT (Name of Village), (Name of block)

District / State

CONTENTS

1. Location
2. Purpose of drilling
3. Drilling history
4. Geology
 - 4.1 Sub surface geology
5. Geophysical logging
6. Well Assembly
7. Well Hydraulics
8. Hydro-Chemistry

A. Plates

1. Site plan.
2. Litho log and Well designs
3. Electrical log - Analog
4. Sp. Capacity V/s Draw down.
5. Time V/s Draw down
6. Discharge V/s Sp. Draw down
7. Stepwise Discharge V/s Losses
8. Time V/s Draw down-Piezometers well
9. Residual draw down V/s t/t' --Piezometers well

Annexures

1. Step draw down Test- Time V/s Draw down
2. Aquifer Performance Test -Time V/s Draw down - Piezometers well
3. Aquifer Performance Test- Residual Draw down V/s t/t' - Piezometers well
4. Drill time log

GOVERNMENT OF HARYANA
Faridabad Metropolitan Development Authority

1. BASIC DATA REPORT

LOCATION : --

BLOCK : ---

DISTRICT/ state : --

CO-ORDINATES : Long: A⁰ B'/C'' E
Lat: X⁰ Y'/Z'' N

SURVEY OF INDIA TOPO SHEET NO. :

BASIC DATA REPORT OF PIEZOMETERS

AT (Name of Village), (Name of block)

District / State

1. LOCATION

Give details of site, along with location approach

2. PURPOSE AND SCOPE

Describe the purpose and scope of ground water exploration

3. DRILLING HISTORY

Brief history of various activities and methods applied in carrying out ground water exploration. In respect of Hard rock, depth at which fracture encountered and discharge measured during drilling of each fracture zone etc. to be furnished.

4. GEOLOGY

Give general geology of the area

4.1 SUB SURFACE GEOLOGY

4.1.1 Litholog

Lithology	Depth range (m)		Thickness (m)
	From	to	

4.1.2 Composite log

Lithology	Depth range (m)		Thickness (m)
	From	to	

5. ELECTRICAL/ NATURAL GAMMA LOGGING OF BOREHOLE

Zones deciphered on the basis of Electrical/ natural gamma logging

S.No.	Depth range (m bgl)	Thickness (m)	

(SAMPLE DRAWINGS FOR CEMENT CONCRETE PLATFORM AND WELL CAP)

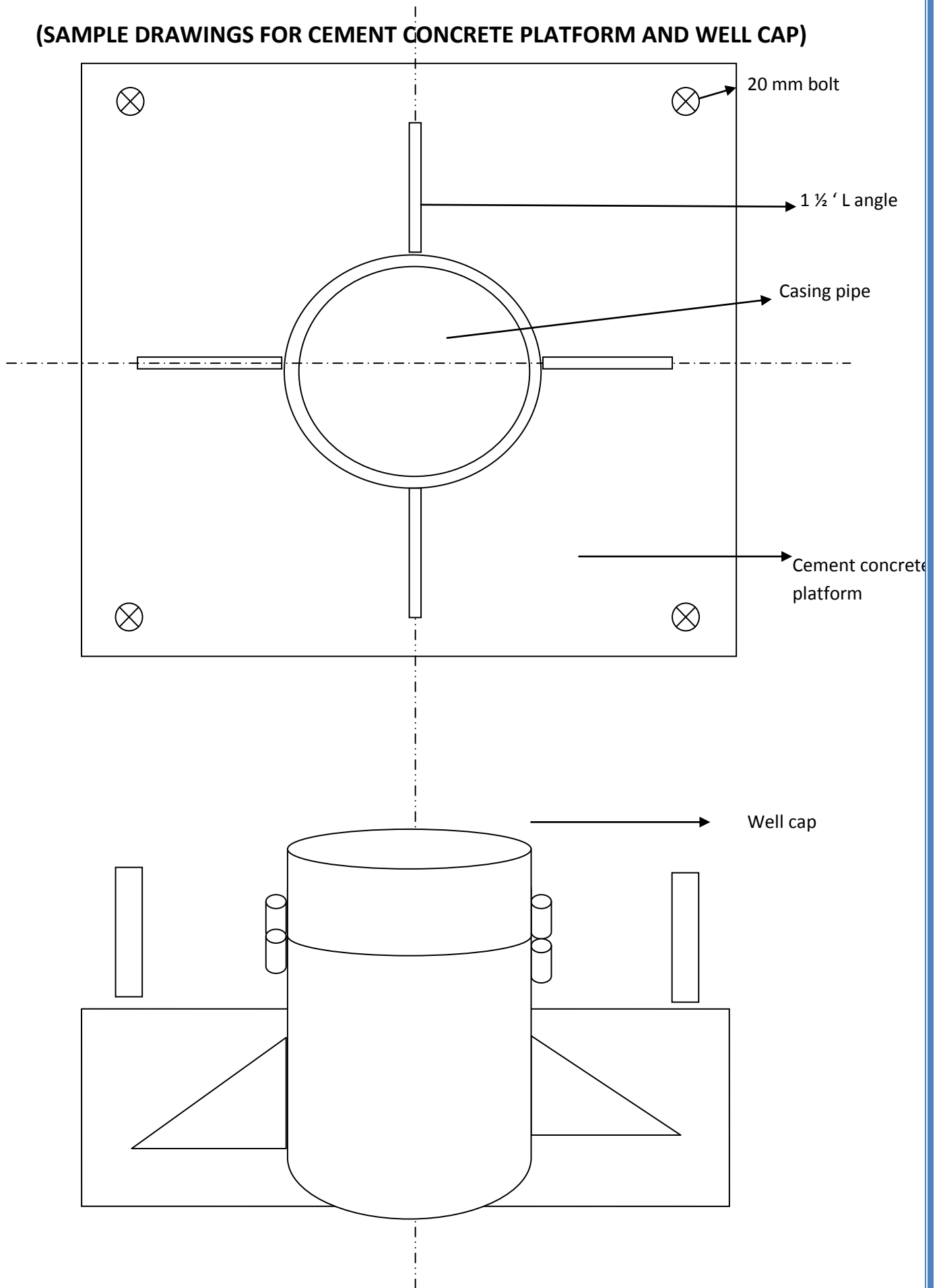

Cement concrete platform

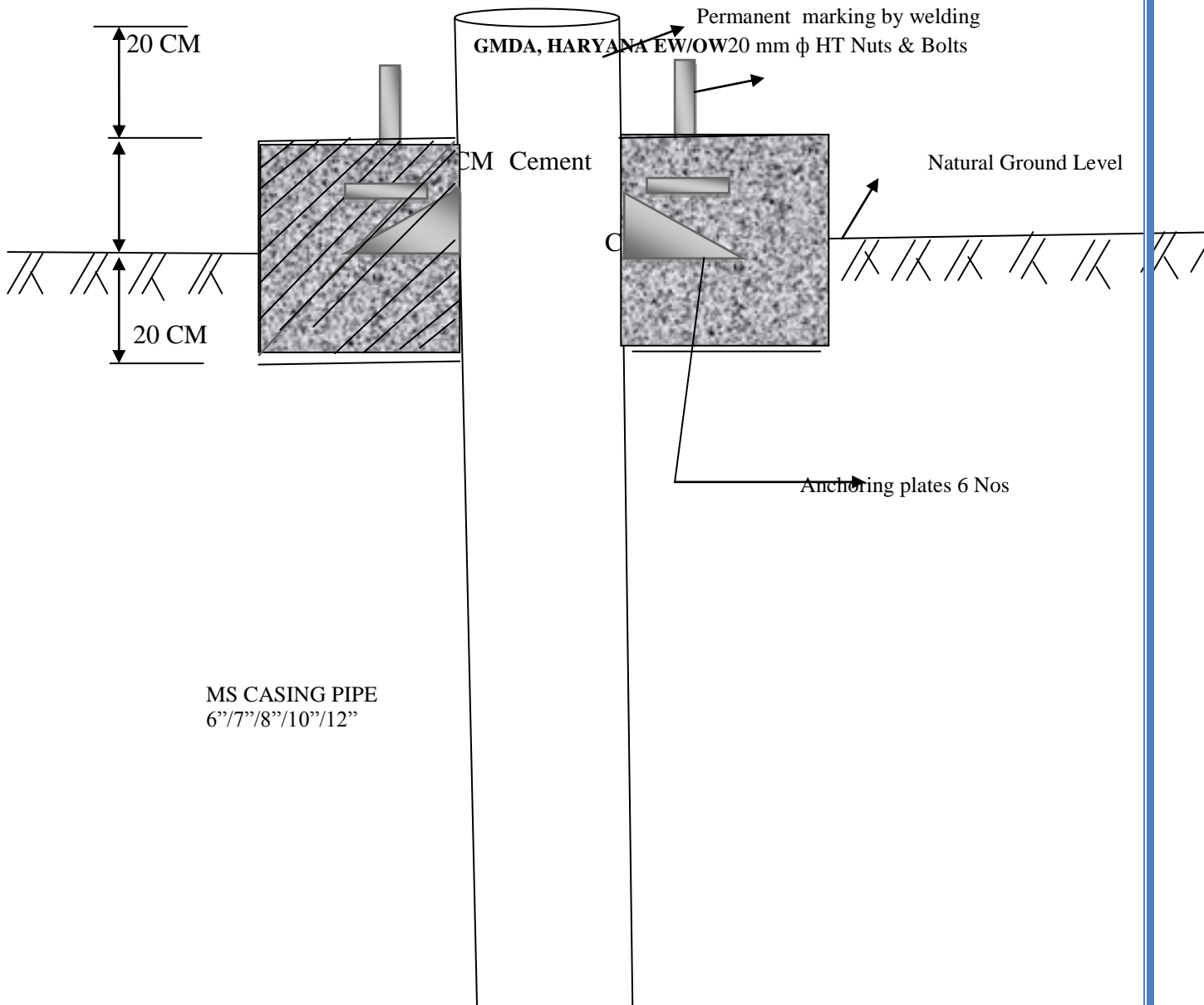

Platform Details: (As per BOQ)

For Example: A cement/ concrete platform measuring 0.70 X 0.70 X 0.60 m (0.30 m above ground level and 0.30m below ground level) around the well casing is to be provided over which protection box is to be provided. The concrete mix ratio is 1:2:4

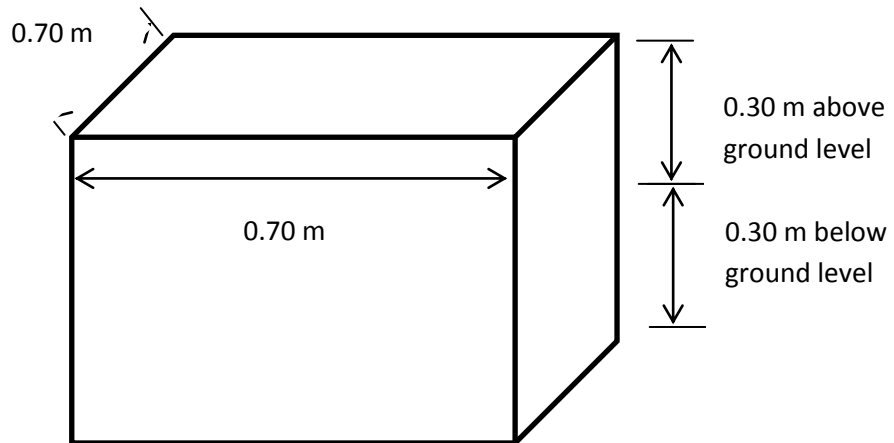

DRAWING OF PROTECTION BOX (made of minimum 3.15 mm GI sheet)

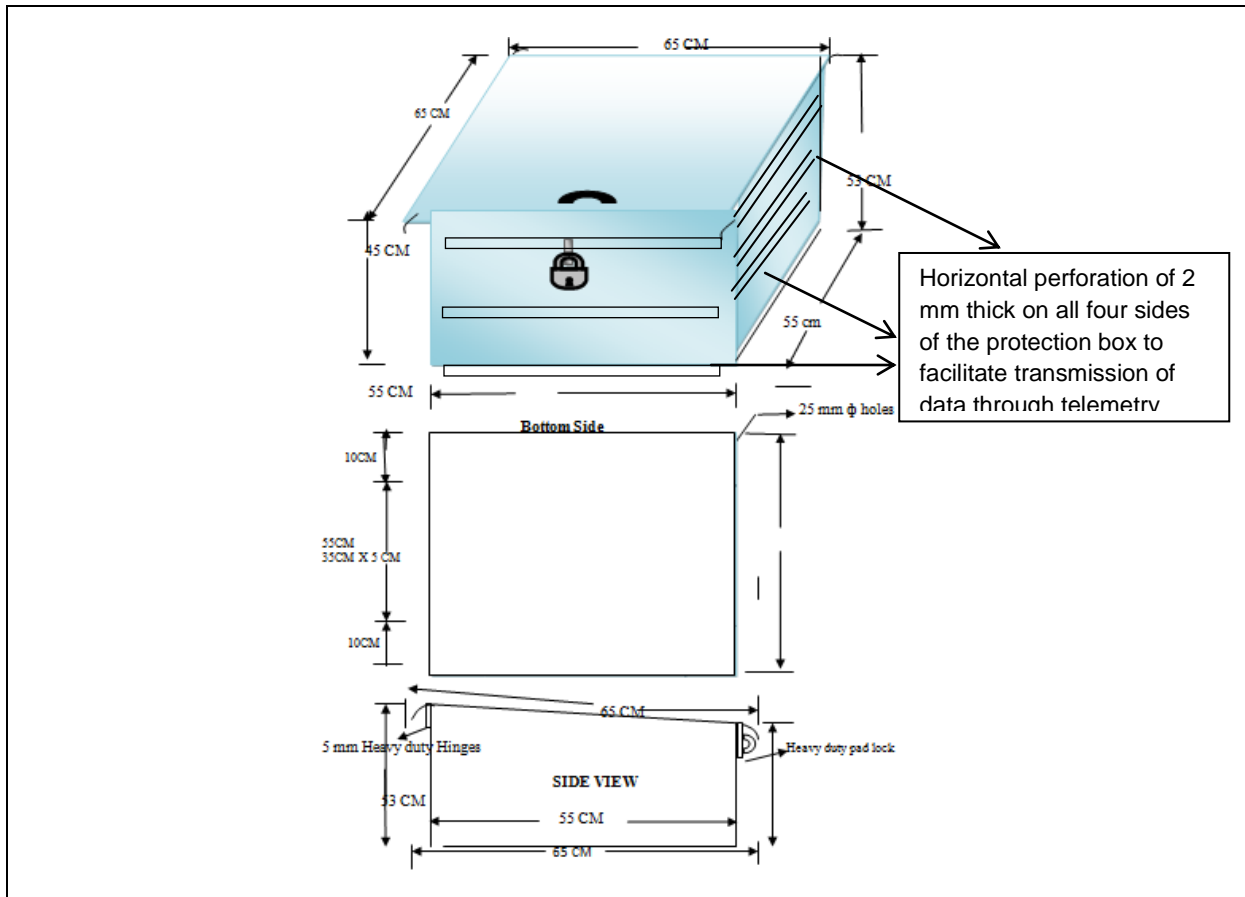

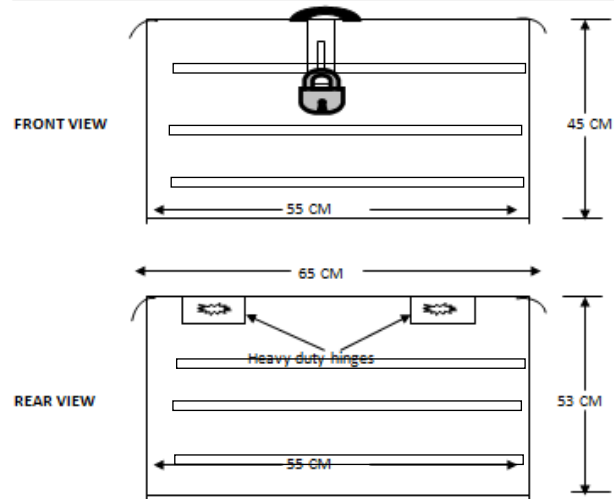

Cover Plate Size:

- 65cm X 65cm (with Handle & Lock)
- The cover plate should have minimum 5mm extra projections on all sides of the box to safe guard the box and the lock against rain
- The edges of the sheet should not be sharp but should be rounded off
- The plate should be made of GI sheet with a minimum thickness of 3.15mm.

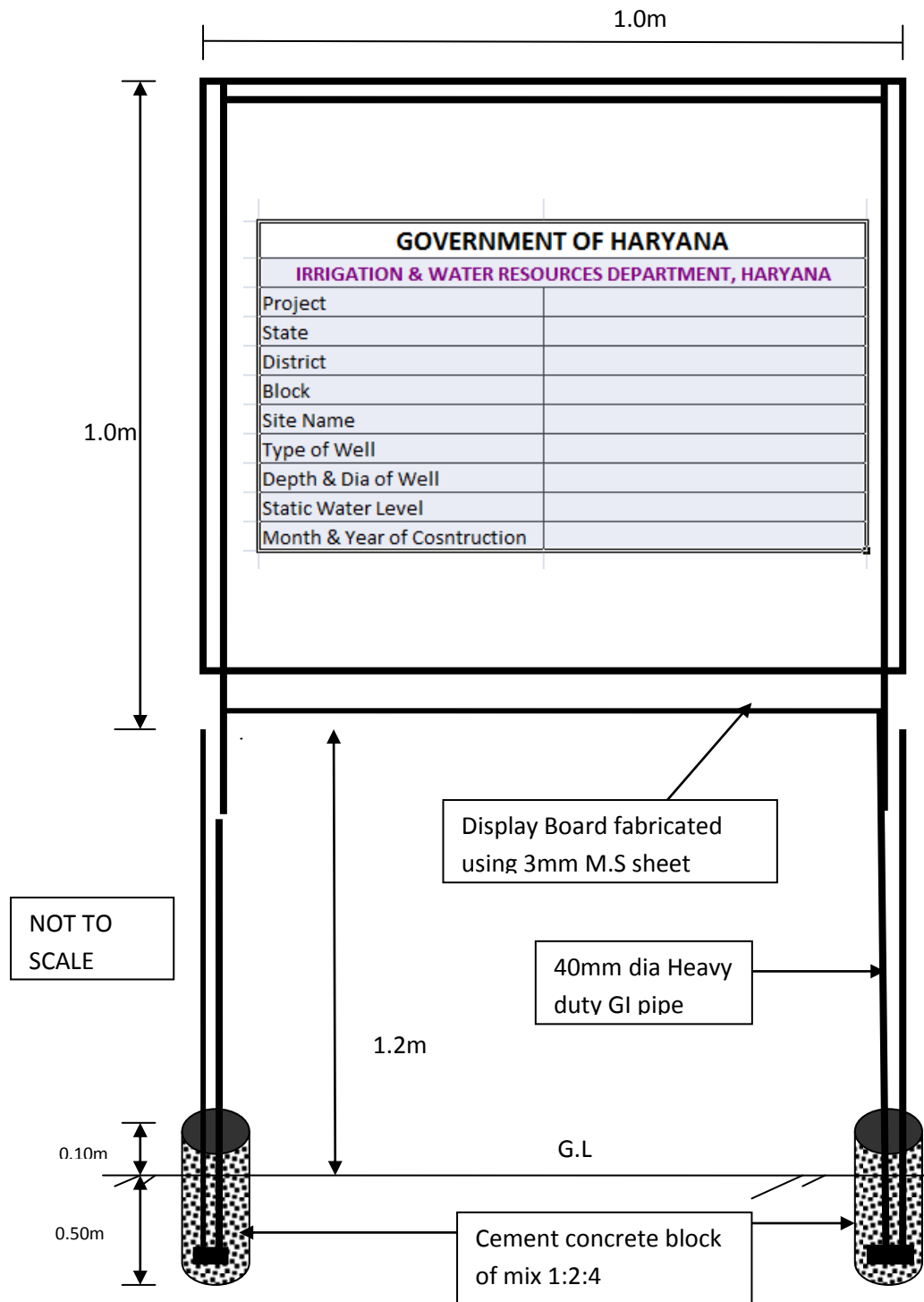

DRAWING OF DISPLAY BOARD

C. Details of Tentative Locations & DWLRs

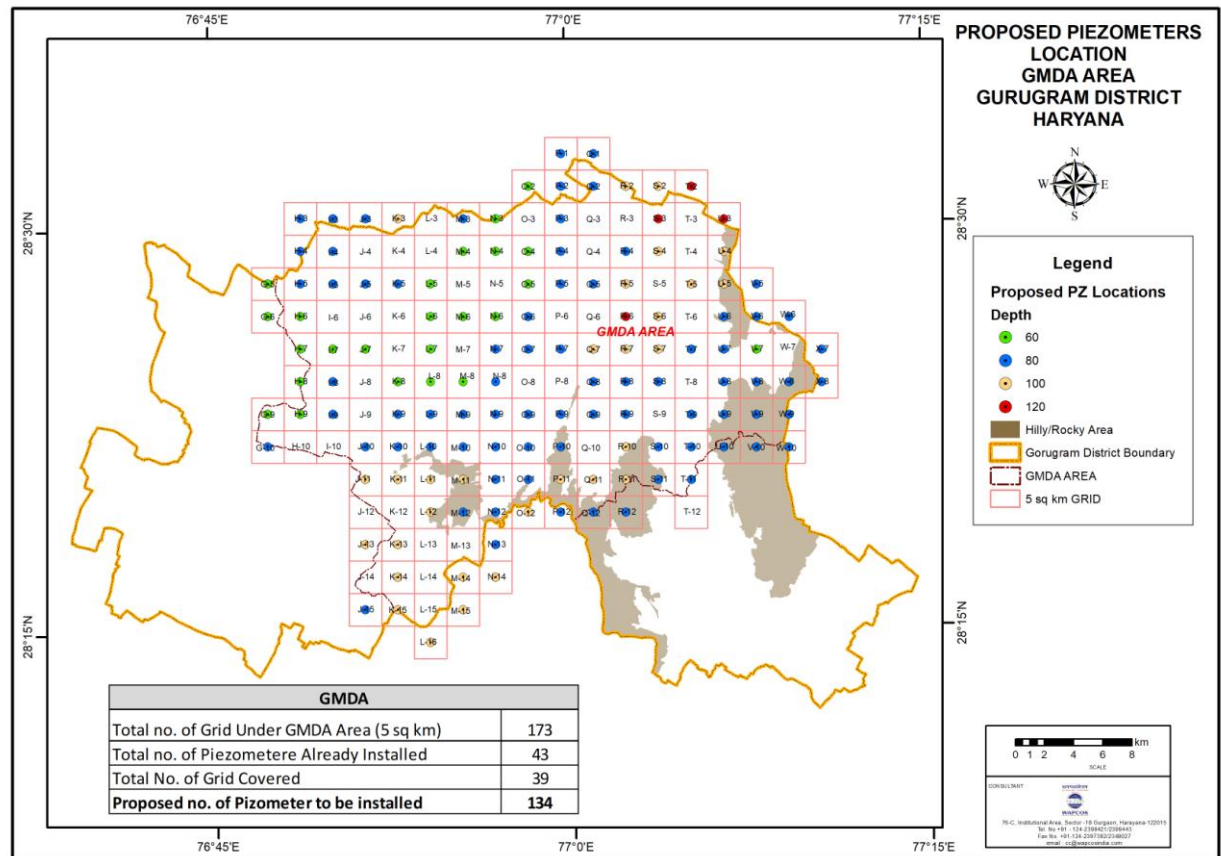

The location/ numbers/ depth of Piezometers, as proposed, may vary depending upon the field condition/requirement.

Form



FORM "A" FINANCIAL STRENGTH

SUB-FORM 'A1'

FINANCIAL INFORMATION

- I. Financial Analysis – Details to be furnished duly supported by figures in balance sheet/ profit & loss account for the last five years duly certified by the Chartered Accountant, as submitted by the applicant to the Income Tax Department (Copies to be attached

Years

--	--	--	--	--

- (i) Gross Annual turnover on construction works
- (ii) Profit/Loss.
- II. Financial arrangements for carrying out the proposed work.
- III. Solvency Certificate from Bankers of the bidder in the prescribed Sub-form "A2"

Signature of Chartered Accountant with Seal

Signature of Bidder(s).

SUB-FORM "A2"

FORM OF BANKERS' CERTIFICATE FROM A SCHEDULED BANK

This is to certify that to the best of our knowledge and information that M/s./ Sh.....having marginally noted address, a customer of our bank are/is respectable and can be treated as good for any engagement upto a limit of Rs..... (Rupees.....)

This certificate is issued without any guarantee or responsibility on the bank or any of the officers.

(Signature)

For the Bank

NOTE (1) Bankers certificates should be on letter head of the Bank, sealed in cover addressed to tendering authority.

(2) In case of partnership firm, certificate should include names of all partners as recorded with the Bank.

Statement of compliance under the requirements of the Volume I Conditions of Contract, Clause 1.2 of the Instructions for Bidders. (Chapter - I, Volume I – Conditions of Contract)

FORM B
PERSONNEL AND ESTABLISHMENT
SUB- FORM "B1" STRUCTURE & ORGANISATION

1. Name & address of the bidder
2. Telephone no./Telex no./Fax no.
3. Legal status of the bidder (attach copies of original document defining the legal status)
 - (a) An Individual
 - (b) A proprietary firm
 - (c) A firm in partnership
 - (d) A limited company or Corporation
4. Particulars of registration with various Government Bodies (attach attested photocopy)

Organisation/Place of registration

Registration No.

1

2

3

5. Names and titles of Directors & Officers with designation to be concerned with this work.
6. Designation of individuals authorized to act for the organization.
7. Was the bidder ever required to suspend construction for a period of more than six months continuously after he commenced the construction? If so, give the name of the project and reasons of suspension of work.
8. Has the bidder, or any constituent partner in case of partnership firm, ever abandoned the awarded work before its completion? If so, give name of the project and reasons for abandonment.
9. Has the bidder, or any constituent partner in case of partnership firm, ever been debarred/black listed for tendering in any organization at any time? If so, give details.
10. Has the bidder, or any constituent partner in case of partnership firm, ever been convicted by the court of law? If so, give details.
11. In which field of Civil Engineering construction the bidder has specialization and interest?
12. Any other information considered necessary but not included above.

Signature of Bidder(s)

SUB-FORM "B2"

DETAILS OF TECHNICAL & ADMINISTRATIVE PERSONNEL TO BE EMPLOYED FOR THE WORK

S.No.	Designation	Total number	Number available for this work	Name	Qualifications	Professional experience and details of work carried out	How these would be involved in this work	Remarks
1	2	3	4	5	6	7	8	9

Signature of Bidder(s)

Statement of compliance under the requirements of the Volume I Conditions of Contract, Clause 1.2 of the Instructions for Bidders. (Chapter - I, Volume I – Conditions of Contract)

Form B3

**(List of the Drilling and Construction Equipment for Construction of Piezometers
Proposed to be deployed)**

S.NO.	Name of Equipment	Name of Manufacturer	Year of Manufacturing	Capacity of the Equipment	Special Skills Required	Ownership of the Equipment	Remarks

Form C

Format for Piezometers/ Exploratory wells/ Deep Tubewell Works Awarded/ Presently under Construction

C-(a)

Description of Work	Place & State	Contract No. & Date	Value of Contract (Rs lakh)	Stipulated period of completion	Value of works* to be completed Rs lakh)	Anticipated date of completion

C-(b): Details for proof of payment in respect of Works mentioned in Table C-(a) .

Sl. No.	Name of Employer	Work Order/Agreement Reference	Payment Received (Rs lakh)	Page no of Documentary proof for payment received enclosed in the Bid

SCHEDULES

SCHEDULE OF TESTS

The various tests to be performed on the various equipment and its components shall be listed out below by the tenderer in sequential order in which these tests will be carried out. The Purchaser, however, reserves the right to modify the sequence of these test.

Sl. No.	Equipment / Components	Tests
Remarks		

For M/s. _____

Signature _____

(By its constituted attorney)

(Seal)

Date _____

Place _____

SCHEDULE NO. 2

SCHEDULE OF MAINTENANCE AND ERECTION TOOLS AND TACKLES

The Tender or shall give below the list of special maintenance and erection tools and tackles offered by him. The price of each item of the tools and tackles shall be furnished separately in the price in the price bid of the tender, if require.

Sl. No.	Details	Quantity	Remarks
----------------	----------------	-----------------	----------------

Certified that the above tools and tackles are essential for erection and maintenance of the equipment and the unit prices of these tools and tackles are furnished separately in the price schedule.

For M/s. _____

Signature _____

(By its constituted attorney)

(Seal)

Date _____

Place _____

ADDITIONAL INFORMATION INCLUDED WITH THE PROPOSAL

We have enclosed with our proposal the following additional information:

Sl. No. Reference and page No.	Description of information
-----------------------------------	----------------------------

For M/s. _____

Signature _____

(By its constituted attorney)

(Seal)

Date _____

Place _____

Note: Continuation sheets of like size and formats may be used as per bidder's requirements

SCHEDULE OF WEIGHTS & DIMENSIONS

The weights and dimensions of various packages for shipment are given below:

Sl. No. In meters	Description	Dimension	Weights in tones	Remarks
----------------------	-------------	-----------	------------------	---------

For M/s. _____

Signature _____

(By its constituted attorney)

(Seal)

Date _____

Place _____

Note: Continuation to sheets of like size and formats may be used as per bidder's requirement and shall be annexed to this schedule

SCHEDULE NO. 5

SCHEDULE OF SUBMISSION OF DRAWINGS / DOCUMENTS

The Tenderer shall list in this schedule all the drawings / documents etc., to be supplied by him as also the date by which each of the drawings / documents etc., would be made available to the Purchaser in the event of placement of order on him.

Sl. No.	Title of the Drawings / Documents from Documents purchaser	Reference to specifications Clause, if any	Date by which Details if any, shall be submitted to the Purchaser	Remarks required the

For M/s. _____

Signature _____

(By its constituted attorney)

(Seal)

Date _____

Place _____

PERFORMANCE GUARANTEE

We hereby guarantee the requirements of this specification. If any of the requirements of the specification is not fulfilled and if capacity, performance and efficiency obtained during acceptance tests fall short of that guaranteed by the Tenderer, the Tenderer hereby affirms that such deficiency will be made good by rectifying / replacing the defective parts within a reasonable time. The tenderer shall bear the whole cost of repair and replacement of defective parts. All the replaced parts shall be removed from the site. While the facility for making goods the deficiency will be normally given once, the Purchaser is entitle to reject the equipment in case of repeated failure to meet the guarantee as per the contract.

Signature _____

Printed Name _____

Designation _____

Common Seal _____

Date _____

Place _____



LIST OF REGISTERS TO BE MAINTAINED AT SITE (To be customized as per site requirements)

1. Site order book
2. Cement register
3. Steel register
4. Concrete cube compressive strength test
5. Slump register
6. Fine aggregate sieve analysis
7. Fine aggregate silt content test
8. 10mm aggregate sieve analysis
9. 10mm aggregate impact value
10. 10mm aggregate Crushing value
11. 20mm aggregate sieve analysis
12. 20mm aggregate impact value
13. 20mm aggregate Crushing value
14. Bricks compressive strength
15. AAC Blocks compressive strength (if applicable)
16. Flakiness and elongation index
17. Rolling margin register
18. 3rd Party Tests

Signature _____

Printed Name _____

Designation _____

Common Seal _____

Date _____

Place _____



**FORMAT OF MATERIAL REGISTER
(To be customized as per site requirements)**

Name of Work:

Name of Contractor:

Name of Item/Construction material:

Total Quantity Required:

Source:

Minimum Size of One Lot:

S.No.	Date	Previous Quantity	Invoice/ Bill No.	Additional Quantity procured	Cumulative Quantity	Issued/ consumed	Cumulative Issue	Balance Outstanding Quantity	Present requirement	Signature of Contractor
1.										
2.										
3.										
4.										

Signature:

Signature:

Name :

Name:

Date :

Date:

For Contractor:

For Department:



Annexures

FORM OF BANK GUARANTEE FOR EARNEST MONEY DEPOSIT

To,

WAPCOS LTD.

(Address of WAPCOS)

WHEREAS, (Name of Bidder) _____ (hereinafter called "the BIDDER") has submitted his bid dated (_____ for the construction of (Name of Contract) _____ (hereinafter called "the Bid").

KNOW ALL MEN by these presents that we (Name of Bank) _____ of (name of Country) _____ having our registered office at _____ (hereinafter called "the Bank") are bound unto the WAPCOS Ltd. in the sum of _____ for which payment well and truly to be made to the WAPCOS Ltd. the Bank binds himself, his successors and assigns by these presents.

SEALED with the Common Seal of the said Bank this _____ day of _____ 2025.

THE CONDITIONS of this obligation are:

- i) If the Bidder withdraws his Bid during the period or bid validity specified in the form of Bid; or
- ii) If the Bidder having been notified of the acceptance of his Bid by WAPCOS Ltd. during the period of bid validity.
 - a) fails or refuses to execute the proforma of Agreement in accordance with the Instruction to Bidders, if required; or
 - b) fails or refuses to furnish the Performance Security , in accordance with the Instructions to Bidder,

We undertake to pay to WAPCOS Ltd. upto the above amount upon receipt of its first written demand, provided that in its demand WAPCOS Ltd. will note that amount claimed by it is due to it owing to the occurrence of one or both of the two conditions, specifying the occurred condition or conditions.

This Guarantee will remain in force upto and including the date 180 days after the closing date for submission of bids as stated in the Invitation to Bid or as extended by you at any time prior to this date, notice of which extension to the Bank being hereby waived, and any demand in respect thereof should reach the Bank not later than the above date.

SIGNATURE OF THE BANK

SEAL

DATE.....

WITNESS

(Signature , Name and Address).

Form of Bid

To

Subject: Bid for Construction of

(Description of Works)

Sir,

With reference to the Bidding Documents forwarded to us under your letter no. _____ dated

1. We the undersigned, having examined the Drawings, Conditions of Contract, specifications and Bill of Quantities for the execution of the above named Works offer to execute and complete the whole of the said Works in conformity with the said Drawing, Conditions of Contract, Specifications and Bill of Quantities given in the Bidding Document for the sum of _____ (Total Bid Price both in figures and words) or such other sum as may be ascertained in accordance with the said Conditions.
2. The Bid Security for the amount of Rs. _____ in the form of _____ is enclosed.
3. We undertake, if our Bid is accepted, to commence the Works within thirty days of receipt of the orders of the Engineer – in – Charge to commence and to complete and deliver the whole of the Works comprised in the Contract within 6.0 months (Time should conform to the timing specified by WAPCOS in the bidding documents) calculated from the last day of the aforesaid period in which the works are to be commenced.
4. If our Bid is accepted, we will furnish a security in the form of the bank guarantee to be jointly and severally bound with us in an amount of 3 percent for drilling works and 10 percent for DWLRs of the above name sum in accordance with the condition of condition of contract.
5. We agree to abide by this Bid for the period of **(120 days)** calendar days from the date of opening of Techno-Commercial Bid and it shall remain binding upon us and may be accepted at any time before the expiration of the period.
6. Unless and until a formal Contract Agreement is executed, this Bid, subsequent correspondences together with the Letter of Award of WAPCOS shall constitute a binding Contract between us and WAPCOS.
7. We understand that WAPCOS is at liberty not to accept the lowest Bid Price. We also understand that WAPCOS is at liberty not to accept any or all Bids and WAPCOS is at liberty to negotiate with Bidder(s) at any stage.

Dated this _____ day of _____ 2025

(Signature and Full Name)

Title _____

(affix seal here)

Firm's address:

Telephone:

Telex:

Cable Address:

Fax:

Witness

(Signature and Full Name)

FORM OF AGREEMENT

Note; This form is included in the Bidding Documents only for the information of Bidders. Only the successful Bidder shall, in due course, be required to fill this form

THIS AGREEMENT MADE the _____ day of _____ 2024 BETWEEN WAPCOS Ltd. _____ of (Mailing address of WAPCOS) _____ (hereinafter called "the WAPCOS") of the one part and (Name of Contractor) _____ of (Mailing address of Contractor) _____ (hereinafter called "the Contractor") of the other part.

WHEREAS the WAPCOS is desirous that certain Works should be executed viz. (Brief description of Works) _____ and has, by a Letter of Acceptance dated _____ accepted a Bid by the Contractor for the execution and completion of such Works.

NOW THIS AGREEMENT WITHNESSETH as follows;

1. In this Agreement words and expressions shall have the same meanings as are respectively assigned to them in the conditions of Contract hereinafter referred to.
2. The following documents shall be deemed to form and be read and construed as part of this Agreement, viz;
 - a) This form of Agreement
 - b) The Letter of Acceptance
 - c) The additional Conditions of Contract.
 - d) The General Conditions of Contract.
 - e) The Technical Specifications
 - f) The Drawings
 - g) The Priced Bill of Quantities.
 - h) The said Bid and Appendix, if any.
 - i) The Invitation to bid.
 - j) The Instructions for Bidders
 - k) The Schedules of Supplementary Information, if any.
3. The aforesaid documents shall be taken as complementary and mutually explanatory of one another, but in case of ambiguities or discrepancies, shall take precedence in the order set out above.
4. In consideration of the payment to be made by WAPCOS Ltd. to the Contractor as hereinafter mentioned, the Contractor hereby covenants with WAPCOS Ltd to execute and complete the Works in conformity, in all respects, with the provisions of the Contract.
5. WAPCOS Ltd. hereby covenants to pay the Contractor, in consideration of the execution and completion of the Works the Contract Price at the times and in the manner prescribed by the Contract.

IN WITNESS whereof the parties hereto have caused their respective common Seals to be hereunto affixed
(or have hereunto set their respective hands and Seals) the and year first above written.

SIGNED, SEALED AND DELIVERED

By the said

By the said

NAME _____

NAME _____

On behalf of the Contractor

On behalf of the WAPCOS

In the presence of;

in the presence of;

NAME _____

NAME _____

Address _____

Address _____

ANNEXURE - IV

FORM OF BANK GUARANTEE FOR PERFORMANCE SECURITY

WAPCOS Limited,
76-C, Sector 18,
Gurgaon-122015.

In consideration of _____ (Employer's name) (hereinafter referred to as "the Employer") which expression shall, unless repugnant to the context or meaning thereof include its successors, administrators and assigns) having awarded to _____ (Contractor's name & address) (hereinafter referred to as "the Contractor " which expression shall unless repugnant to the context or meaning thereof, include its successors, administrators, executors and assigns) a contract, by issue of Employer's Notification of Award No. _____ dt. _____ and the same having been unequivocally accepted by the Contractor, resulting into a contract valued at Rs. _____ (Rupees _____ only) for _____ (name of work) (hereinafter called " the contract") and the Contractor having agreed to provide a Contract Performance Guarantee for the faithful performance of the entire contract equivalent to Rs. _____ (Rupees _____ only) (10 % for Drilling Works & 10 % for Goods) of the said value of the Contract to the Employer.

We, _____ (name & address of bank) (hereinafter referred to as "the Bank" which expression shall, unless repugnant to the context or meaning thereof, include its successors, administrators, executors and assigns) do hereby guarantee and undertake to pay the Employer, on demand any or, all monies payable by the Contractor to the extent of Rs. _____ (Rupees _____ only) as aforesaid at any time upto _____ without any demur, reservation, contest , recourse or protest and/or without any reference to the Contractor. Any such demand made by the Employer on the bank shall be conclusive and binding notwithstanding any difference between the Employer and the Contractor or any dispute pending before any Court, Tribunal, Arbitrator or any other authority. The Bank undertakes not to revoke this guarantee during its currency without previous consent of the Employer and further agrees that the guarantee herein contained shall continue to be enforceable till the Employer discharges this guarantee.

We the said Bank further agree that the guarantee herein contained shall remain in full force and effect during the period that would be taken for the performance of the said Contract and that it shall continue to be enforceable till all the dues of the Employer under or by virtue of the said contract have been fully paid and its claims satisfied or discharged or till the Employer certifies that the terms and conditions of the said Contract have been fully and properly carried out by the said Contractor and accordingly discharges the guarantee.

The Employer shall have the fullest liberty without affecting in any way the liability of the Bank under this guarantee, from, time to time to extend the time for performance of the Contract by the Contractor. The Employer shall have the fullest liberty without affecting this guarantee, to postpone from time to time the exercise of any powers vested in them or of any right which they might have against the Contractor and to exercise the same at any time in any manner and either to enforce or to forbear to enforce any covenants, contained or implied, in the Contract between the Employer and the Contractor or any other course or remedy or security available to the Employer. The bank shall not be released of its obligations under these presents by any exercise by the Employer of its liberty with reference to the matters aforesaid or any of them or by reason of any other act or forbearance or other acts of omission or

commission on the part of the Employer or any other indulgence shown by the Employer or by any other matter or thing whatsoever which under law would but for this provision, have the effect of relieving the Bank. The guarantee shall not be affected by a change in the constitution of the bank or of the employer.

The bank also agrees that the Employer at its option shall be entitled to enforce this Guarantee against the Bank as a principal debtor, in the first instance, without proceeding against the Contractor and notwithstanding any security or other guarantee that the Employer may have in relation to the Contractor's liabilities.

We The Said Bank do hereby declare that we have absolute and unconditional power to issue this guarantee in your favour under the Memorandum and Articles of Association or such other constitutional documents of the Bank and the undersigned have full power to execute this guarantee under the Power of Attorney/ Post Approval Authorization dated _____ of the bank granted to him / us by the Bank. We the said bank do hereby declare and undertake that your claim under the guarantee shall not be affected by any deficiency or other defect in the powers of the bank or its officials and the guarantee shall be deemed to have been issued as if the bank and its officials have all the powers and authorization to give this guarantee on behalf of the bank.

We the said bank do hereby certify the genuineness and appropriateness of the Stamp paper and stamp value used for issuing the guarantee. We the said bank do hereby declare and undertake that your claim under the guarantee shall not be affected by any deficiency or other defect in the stamp paper or its stamp value.

We the said bank do hereby declare that our payments hereunder shall be made to you , free and clear of and without and deduction, reduction on account of any reasons including any and all present and future taxes, levies, charges of withholding whatsoever imposed or collected with respect thereto.

Notwithstanding anything contained hereinabove our liability under this guarantee is restricted to Rs. _____ (Rupees _____ only) and it shall remain in force upto and including _____ and shall be extended from time to time for such period as may be desired by M/S WAPCOS Limited on whose behalf this bank guarantee has been given.

Notwithstanding anything contained herein

- i) our liability under this guarantee shall not exceed Rs. _____ (Rupees _____ only);
- ii) This bank guarantee shall be valid upto and till _____ only, being the date of expiry of the guarantee and
- iii) We are liable to pay up to the guaranteed amount only and only if we receive from you a written claim or demand within the claim period not later than 12 months from the said expiry date relating to default that happened during the guarantee period and all your rights under this bank guarantee shall be extinguished and our liability under the bank guarantee shall stand discharged unless such written claim or demand is received by us from you on or before being the date of expiry of the guarantee

Dated this _____ day of _____ at New Delhi.

Well Development:

The well should be developed by air compressor and over pumping unit to ensure sand free discharge and optimal yield.

a) Development by Air Compressor

During, development by air compressor, the operation shall be carried out as under:

- 1) Development by compressor need to be carried out by using suitable air pressure as per site requirement.
- 2) Suitable size Eduction pipe need to be used as discharge pipe and suitable air line should be used for air supply.
- 3) The development should commence from the top of aquifer tapped and should be carried out towards bottom and the development operation should be repeated again from top to bottom.
- 4) The development with Air compressor for exploratory well as well as observation well should be carried out till the water becomes mud/sand free in Exploratory Wells/ Observation Wells. Any changes during the development recommended by WAPCOS Site-in-Charge should be considered immediately by the Contractor.

b) Development by Over-pumping Unit (Pre-Pumping)

Suitable submersible pump of required discharge range with suitable lift-up capacity need to be lowered for development of Exploratory bore holes to ensure sand free discharge. The recommendation for discharge will be shared with contractor after development of well. Alternatively, turbine pump of suitable capacity can also be used for development by Pumping test unit. The Development of Exploratory well by over pumping will be carried out as per Bill of Quantity till the water becomes clear free from sand/ Silt and clay etc.

All the equipment including POL & Labour required for carrying out tests but not limited to the following shall be arranged by the Contractor at his own cost:

- i) A suitable pump and prime mover (since power is not available at the well site).
- ii) Measuring devices for time, discharge and V-Notch orifice method water level recorder (Digital water meter recorder /steel tape engraved).
- iii) 25 mm airline needed to be lowered in the test well as well as observation well up to required depth.

Tender Form

To
General Manager (GWRDM)
WAPCOS (I) Ltd.
76-C, Sector – 18,
Institutional Area
Gurgaon, Haryana – 122015

Dear Sir,

- 1) I/ We have read and examined the following tender documents relating to the work of **“Drilling, construction of approx. 134 nos. piezometers with supply, installation and commissioning of 134 nos. Digital Water Level Recorder (DWLRs) along with supply, installation and commissioning of 49 nos. Digital Water Level Recorder (DWLRs) in Existing Piezometers under GMDA area”**.
 - a) Notice inviting tender
 - b) Brief description of the work
 - c) Instructions for tenders
 - d) General conditions of contract
 - e) Additional conditions of Contract
 - f) Annexures
 - g) Formats
- 2) I / We hereby tender for the entire consulting services for the works referred to in the documents mentioned in contract documents upon the terms and conditions contained or referred to in the aforesaid documents.
- 3) I/ We agree to keep this tender open for acceptance for 120 days from the date of opening thereof and also agree not to make any modification in the terms and conditions on our own accord.
- 4) As sum of _____ **(in words)** is hereby forwarded as demand draft/ bank guarantee from schedule bank in favour of WAPCOS Ltd. Payable at New Delhi, as earnest money. I/ We agree that if I / We fail to keep the validity of tender open as aforesaid, or make any modification in the terms and conditions of my / our tender on our accord and / or after the acceptance of our tender if I / We fail to commence the execution of the works as provided in the documents referred to in paragraph 1 above. I / We shall become liable for forfeiture of my / our earnest money as aforesaid, and the corporation project shall without prejudice to any other right or remedy, be at liberty to forfeit the said earnest money absolutely.

Should this tender be accepted. I / We agree to abide by and fulfill all the terms and conditions and provisions of the above mentioned tender documents.

Thanking you,

Yours faithfully,

(Bidder)

MANUFACTURER'S AUTHORISATION FORM

To

WAPCOS Ltd.
9 C, 9th Floor, Hansalaya Building,
Barakhamba Road,
New Delhi,
Delhi-110001

Reference: Your Tender Enquiry Document No. WAP/ GWRD&M/ DRILLING-DWLR/2024-25/ GMDA /Feb-25/1 for Drilling, construction of approx. 134 nos. piezometers with supply, installation and commissioning of 134 nos. Digital Water Level Recorder (DWLRs) along with supply, installation and commissioning of 49 nos. Digital Water Level Recorder (DWLRs) in Existing Piezometers under GMDA area.

Dear Sirs,

We, _____ (Name of the Manufacturer), who are proven and reputed manufacturers of _____ (Name and Model of equipment offered in Tender document) having factories at _____ (Address of the Manufacturer), hereby authorise Messrs _____ (Name and Address of the Agent) to submit a tender, process the same further and enter into a contract with you against your requirement as contained in the above referred tender enquiry documents for the above goods manufactured by us.

We further confirm that no supplier or firm or individual other than Messrs. _____ (Name and Address of the Agent) is authorised to submit a tender, process the same further and enter into a contract with you against your requirement and technical specification as contained in the above referred tender enquiry documents for the above goods manufactured by us.

We also hereby extend our comprehensive warranty and Comprehensive Annual Maintenance, as applicable as per clause 29 of the General Conditions of Contract, read with modification and corrigendum, if any, in contract for the goods and services offered for supply by the above firm against this tender enquiry document.

The authorized representative in India shall submit the performance security of specified amount as per requirement of Clause-29 of Instructions to Bidder and Clause-14 of General Condition of Contract of tender document.

Yours faithfully,

{Signature of the Authorised Officer of the Manufacturer}

{Name and Designation of the Officer}

For and on behalf of

{Seal, Name & Address of the Manufacturer}

Note: This letter of authorisation should be on the letter head of the manufacturing firm and should be signed by a person competent and having the power of attorney to legally bind the manufacturer

Undertaking for not Corrupt/Fraudulent Practices
(On Firm's Letter Head)

Certified that I/We (Name) _____ are not under a declaration of ineligibility for corrupt and fraudulent practices issued by the Government of India or by any State Government of India/any multilateral institutions or any project authorities till date.

Date:

(Signature of the Bidder)

INTEGRITY PACT

To be signed by the bidder and same signatory competent / authorized to sign the relevant contract on behalf of WAPCOS Limited

INTEGRITY AGREEMENT

This Integrity Agreement is made at on this day of 20.....

BETWEEN

_____ represented through,, (Name of Division),
....., (Hereinafter referred as the (Address of Division)
'Purchaser/Owner', which expression shall unless repugnant to the meaning or context hereof include its successors and permitted assigns)

AND

..... (Name and Address of the
Individual/firm/Company) through (Hereinafter referred to as the
(Details of duly authorized signatory)

"Bidder/Contractor" and which expression shall unless repugnant to the meaning or context hereof include its successors and permitted assigns)

Preamble

WHEREAS the Purchaser/Owner has floated the Tender (NIT No.) (hereinafter referred to as "Tender/Bid") and intends to award, under laid down organizational procedure, contract for Drilling, construction of approx. 134 nos. piezometers with supply, installation and commissioning of 134 nos. Digital Water Level Recorder (DWLRs) along with supply, installation and commissioning of 49 nos. Digital Water Level Recorder (DWLRs) in Existing Piezometers under GMDA area.

hereinafter referred to as the "Contract".

AND WHEREAS the Purchaser/Owner values full compliance with all relevant laws of the land, rules, regulations, economic use of resources and of fairness/transparency in its relation with its Bidder(s) and Contractor(s).

AND WHEREAS to meet the purpose aforesaid both the parties have agreed to enter into this Integrity Agreement (hereinafter referred to as " Integrity Pact" or " Pact"), the terms and conditions of which shall also be read as integral part and parcel of the Tender/Bid documents and Contract between the parties.

NOW, THEREFORE, in consideration of mutual covenants contained in this Pact, the parties hereby agree as follows and this Pact witnesses as under:

Article 1: Commitment of the Purchaser/Owner

- 1) The Purchaser/Owner commits itself to take all measures necessary to prevent corruption and to observe the following principles:
 - (a) No employee of the Purchaser/Owner, personally or through any of his/her family members, will in connection with the Tender, or the execution of the Contract, demand, take a promise for or accept, for self or third person, any material or immaterial benefit which the person is not legally entitled to.
 - (b) The Purchaser/Owner will, during the Tender process, treat all Bidder(s) with equity and reason. The Purchaser/Owner will, in particular, before and during the Tender process, provide to all Bidder(s) the same information and will not provide to any Bidder(s) confidential / additional information through which the Bidder(s) could obtain an advantage in relation to the Tender process or the Contract execution.
 - (c) The Purchaser/Owner shall endeavour to exclude from the Tender process any person, whose conduct in the past has been of biased nature.
- 2) If the Purchaser/Owner obtains information on the conduct of any of its employees which is a criminal offence under the Indian Penal code (IPC)/Prevention of Corruption Act, 1988 (PC Act) or is in violation of the principles herein mentioned or if there be a substantive suspicion in this regard, the Purchaser/Owner will inform the Chief Vigilance Officer and in addition can also initiate disciplinary actions as per its internal laid down policies and procedures.

Article 2: Commitment of the Bidder(s)/Contractor(s)

- 1) It is required that each Bidder/Contractor (including their respective officers, employees and agents) adhere to the highest ethical standards, and report to the Government / Department all suspected acts of **fraud or corruption or Coercion or Collusion** of which it has knowledge or becomes aware, during the tendering process and throughout the negotiation or award of a contract.
- 2) The Bidder(s)/Contractor(s) commits himself to take all measures necessary to prevent corruption. He commits himself to observe the following principles during his participation in the Tender process and during the Contract execution:
 - a) The Bidder(s)/Contractor(s) will not, directly or through any other person or firm, offer, promise or give to any of the Purchaser/Owner's employees involved in the Tender process or execution of the Contract or to any third person any material or other benefit which he/she is not legally entitled to, in order to obtain in exchange any advantage of any kind whatsoever during the Tender process or during the execution of the Contract.
 - b) The Bidder(s)/Contractor(s) will not enter with other Bidder(s) into any undisclosed agreement or understanding, whether formal or informal. This applies in particular to prices, specifications, certifications, subsidiary contracts, submission or non-submission of bids or any other actions to restrict competitiveness or to cartelize in the bidding process.
 - c) The Bidder(s)/Contractor(s) will not commit any offence under the relevant IPC/PC Act. Further the Bidder(s)/Contractor(s) will not use improperly, (for the purpose of competition or personal gain), or pass on to others, any information or documents provided by the Purchaser/Owner as part of the business relationship, regarding plans, technical proposals and business details, including information contained or transmitted electronically.

- d) The Bidder(s)/Contractor(s) of foreign origin shall disclose the names and addresses of agents/representatives in India, if any. Similarly Bidder(s)/Contractor(s) of Indian Nationality shall disclose names and addresses of foreign agents/representatives, if any. Either the Indian agent on behalf of the foreign principal or the foreign principal directly could bid in a tender but not both. Further, in cases where an agent participate in a tender on behalf of one manufacturer, he shall not be allowed to quote on behalf of another manufacturer along with the first manufacturer in a subsequent/parallel tender for the same item.
- e) The Bidder(s)/Contractor(s) will, when presenting his bid, disclose any and all payments he has made, is committed to or intends to make to agents, brokers or any other intermediaries in connection with the award of the Contract.
- 3) The Bidder(s)/Contractor(s) will not instigate third persons to commit offences outlined above or be an accessory to such offences.
- 4) The Bidder(s)/Contractor(s) will not, directly or through any other person or firm indulge in fraudulent practice **means a wilful misrepresentation or omission of facts or submission of fake/forged documents in order to induce public official to act in reliance thereof, with the purpose of obtaining unjust advantage by or causing damage to justified interest of others and/or to influence the procurement process to the detriment of the Government interests.**
- 5) The Bidder(s)/Contractor(s) will not, directly or through any other person or firm use Coercive Practices (means the act of obtaining something, compelling an action or influencing a decision through intimidation, threat or the use of force directly or indirectly, where potential or actual injury may befall upon a person, his/ her reputation or property to influence their participation in the tendering process).

Article 3: Consequences of Breach

Without prejudice to any rights that may be available to the Purchaser/Owner under law or the Contract or its established policies and laid down procedures, the Purchaser/Owner shall have the following rights in case of breach of this Integrity Pact by the Bidder(s)/Contractor(s) and the Bidder/Contractor accepts and undertakes to respect and uphold the Purchaser/Owner's absolute right:

- 1) If the Bidder(s)/Contractor(s), either before award or during execution of Contract has committed a transgression through a violation of Article 2 above or in any other form, such as to put his reliability or credibility in question, the Purchaser/Owner after giving 14 days notice to the contractor shall have powers to disqualify the Bidder(s)/Contractor(s) from the Tender process or terminate/determine the Contract, if already executed or exclude the Bidder/Contractor from future contract award processes. The imposition and duration of the exclusion will be determined by the severity of transgression and determined by the Purchaser/Owner. **Such exclusion may be forever or for a limited period as decided by the Purchaser/Owner.**
- 2) **Forfeiture of EMD/Performance Guarantee/Security Deposit:** If the Purchaser/Owner has disqualified the Bidder(s) from the Tender process prior to the award of the Contract or terminated/determined the Contract or has accrued the right to terminate/determine the Contract according to Article 3(1), the Purchaser/Owner apart from exercising any legal rights that may have accrued to the Purchaser/Owner, may in its considered opinion forfeit the entire

amount of Earnest Money Deposit, Performance Guarantee and Security Deposit of the Bidder/Contractor.

- 3) **Criminal Liability:** If the Purchaser/Owner obtains knowledge of conduct of a Bidder or Contractor, or of an employee or a representative or an associate of a Bidder or Contractor which constitutes corruption within the meaning of IPC Act, or if the Purchaser/Owner has substantive suspicion in this regard, the Purchaser/Owner will inform the same to law enforcing agencies for further investigation.

Article 4: Previous Transgression

- 1) The Bidder declares that no previous transgressions occurred in the last 5 years with any other Company in any country confirming to the anticorruption approach or with Central Government or State Government or any other Central/State Public Sector Enterprises in India that could justify his exclusion from the Tender process.
- 2) If the Bidder makes incorrect statement on this subject, he can be disqualified from the Tender process or action can be taken for banning of business dealings/ holiday listing of the Bidder/Contractor as deemed fit by the Purchaser/Owner.
- 3) If the Bidder/Contractor can prove that he has resorted / recouped the damage caused by him and has installed a suitable corruption prevention system, the Purchaser/Owner may, at its own discretion, revoke the exclusion prematurely.

Article 5: Equal Treatment of all Bidders/Contractors/Subcontractors

- 1) The Bidder(s)/Contractor(s) undertake(s) to demand from all subcontractors a commitment in conformity with this Integrity Pact. The Bidder/Contractor shall be responsible for any violation(s) of the principles laid down in this agreement/Pact by any of its Sub-contractors/sub-vendors.
- 2) The Purchaser/Owner will enter into Pacts on identical terms as this one with all Bidders and Contractors.
- 3) The Purchaser/Owner will disqualify Bidders, who do not submit, the duly signed Pact between the Purchaser/Owner and the bidder, along with the Tender or violate its provisions at any stage of the Tender process, from the Tender process.

Article 6- Duration of the Pact

This Pact begins when both the parties have legally signed it. It expires for the Contractor/Vendor 12 months after the completion of work under the contract or till the continuation of defect liability period, whichever is more and for all other bidders, till the Contract has been awarded.

If any claim is made/lodged during the time, the same shall be binding and continue to be valid despite the lapse of this Pacts as specified above, unless it is discharged/determined by the Competent Authority.

Article 7- Other Provisions

- 1) This Pact is subject to Indian Law, place of performance and jurisdiction is the **Head quarters of the Division** of the Purchaser/Owner, who has floated the Tender.
- 2) Changes and supplements need to be made in writing. Side agreements have not been made.
- 3) Should one or several provisions of this Pact turn out to be invalid; the remainder of this Pact remains valid. In this case, the parties will strive to come to an agreement to their original intentions.
- 4) It is agreed term and condition that any dispute or difference arising between the parties with regard to the terms of this Integrity Agreement / Pact, any action taken by the Owner/Purchaser in accordance with this **Integrity Agreement/ Pact or interpretation thereof shall not be subject to arbitration.**

Article 8- LEGAL AND PRIOR RIGHTS

All rights and remedies of the parties hereto shall be in addition to all the other legal rights and remedies belonging to such parties under the Contract and/or law and the same shall be deemed to be cumulative and not alternative to such legal rights and remedies aforesaid. For the sake of brevity, both the Parties agree that this Integrity Pact will have precedence over the Tender/Contract documents with regard any of the provisions covered under this Integrity Pact.

IN WITNESS WHEREOF the parties have signed and executed this Integrity Pact at the place and date first above mentioned in the presence of following witnesses:

.....
(For and on behalf of Purchaser/Owner)

.....
(For and on behalf of Bidder/Contractor)

WITNESSES:

1.
(signature, name and address)

2.
(signature, name and address)

Place:

Dated:

(FORMAT OF UNDERTAKING TO BE FURNISHED ON COMPANY LETTER HEAD WITH REGARD TO BLACKLISTING/NON-DEBARMENT, BY CONTRACTING AGENCY)

UNDERTAKING REGARDING BLACKLISTING/NON-DEBARMENT

Name of Work:

Ref: Tender No..... dated.....

To,

Engineer In charge of Project,
WAPCOS Limited,

This is to certify that we have taken the cognizance of Blacklisting Policy of WAPCOS Ltd. further, we hereby confirm and declare that we, M/s _____, is not blacklisted/ De-registered/ debarred by any Government department/ Public Sector Undertaking/ Private Sector/ or any other agency for which we have Executed/ Undertaken the works/Services during the last 05 years.

For -----

Authorised Signatory

Date:

CHECKLIST

(Please ensure that you have serially numbered each and every page of scanned documents forming your bid and furnished following documents in the manner prescribed mentioning the page number(s) of your bid in appropriate box) This Checklist should be the first document of your bid numbered as page 1.

Tender Clause No.	The Bidding Documents	Reference Page No(s) where the documents are uploaded
<p>1.2 Eligibility criteria</p>	<p>This invitation to bid is open to any bidder meeting the following requirements :</p> <p>The bidder shall be qualified for the contract as notified by the Employer in subsequent clauses.</p> <p>1.2.1 Any tenderer, (proprietorship firms, partnerships firms, companies, corporations, joint ventures) registered with Central or State Government or the Central Ground Water Authority (CGWA) are eligible to participate in the tender. A self attested copy in respect of valid registration/ enlistment with the respective authorities is to be submitted</p> <p>1.2.2 Bidders are permitted to form consortium/Joint Venture. The clauses as given below shall be applicable for consortium /Joint Venture.</p> <div style="border: 1px solid black; padding: 5px;"> <ul style="list-style-type: none"> vii In case of a consortium /Joint Venture, certified copy of the agreement between various partners shall be submitted with the tender. viii The consortium /Joint Venture shall nominate a Representative who shall have the authority to conduct all business for and on behalf of any and all the members of the JV during the bidding process and, in the event the JV is awarded the Contract, during contract execution. ix The consortium /Joint Venture will identify a lead partner who will be authorised to execute the contract with the department. All financial transactions and liabilities shall rest with the lead partner. x JV members are jointly and severally responsible and liable for the contract. For pre- qualification, the JV should fulfil the criteria specified in the pre-qualification document. The attributes to be evaluated will be the same as for individual contractors; however, certain parameters up to the specified limits have to be essentially met by them collectively, some by the lead partner, and some by the other partner, as briefly described below: </div> <div style="border: 1px solid black; padding: 5px; margin-top: 5px;"> <p>X. Qualifying factors to be met collectively: (A) Annual turnover from construction; (B) Nos. of Well construction experience</p> <p>Y. Qualifying factors for lead partner: (A) Nos. of Well construction experience Not less than of 50 (fifty) percent of the respective limits of above criteria prescribed in case of individual contractors may be accepted;</p> <p>Z. Qualifying factors for other partner: Same as for lead partner except that for the factors specified in (Y)</p> </div>	

	<p>above, a lower limit of 25 (twenty-five) per cent.</p> <ul style="list-style-type: none"> xi A tenderer shall submit only one bid in the same tendering process, either individually as a tenderer or as a partner of a consortium /Joint Venture. xii Number of the members/firms in a joint venture shall not be more than two including the lead partner. <p>1.2.3 A Bidder shall not have a conflict of interest. Any Bidder found to have a conflict of interest shall be disqualified. A Bidder may be considered to have a conflict of interest for the purpose of this bidding process, if the Bidder:</p> <ul style="list-style-type: none"> vi directly or indirectly controls, is controlled by or is under common control with another Bidder or vii receives or has received any direct or indirect subsidy from any other Bidder;or viii has the same legal representative as another Bidder; or ix has a relationship with another Bidder, directly or through common third parties, that puts it in a position to influence the bid of another Bidder, or influence the decisions of the Purchaser regarding this bidding process; or x participates in more than one bid in this bidding process. Participation by a Bidder in more than one Bid will result in the disqualification of all Bids in which such Bidder is involved. 	
<p>B</p>	<p>1.2.4 All the Bidder should specify the their DWLR Original Equipment Manufacture (OEM)/Authorized Suppliers (Number of such DWLR OEM/authorized Suppliers should not more than 1) and give an undertaking that they will supply DWLR from those reputed DWLR OEM/Authorized Suppliers only and clearly mentioning the numbers of DWLR to be supplied by OEM/authorized Suppliers as per specifications of DWLRs mentioned in the Tender Document.</p> <p>1.2.5 Bidders will be required to employ at ground water professional with minimum qualification of graduate degree in engineering/master's degree in geosciences with minimum 3 years of experience in construction of exploratory & observation, Piezometer wells and similar works. The undertaking for employment of these ground water professional be given.</p> <p>The bidder must ensure to deploy required equipment as proposed in the format within the mobilization period till the completion of the project, otherwise WAPCOS shall be free to terminate the work due to non-mobilization of equipment as committed in the tender without any notice. In case bidder submit details of machinery hired or taken on lease, then bidder shall obtain affidavits on stamp paper verified by notary from owner of the machinery and shall submit the same along with the bid. Ownership record of the machinery such as copy of registration certificate, purchase memo etc. shall also be submitted.</p> <p>Details required for Equipments and Manpower are as under:</p>	<p>In the BOQ template Online</p>

Table – 2

Equipments/ Machineries (own)	No.	Manpower (Regular/ Contract)	No.
Drilling Rigs:	5	Geologist	3
Air Compressor:	1	Geophysicist (Analysis Basis)	1
Geophysical Logger:	1	Project Engineer For DWLR	1

(Note: Minimum Man power and Machinery as stated above should be arranged by the bidder separately and bidder can deploy manpower and machineries as per site requirement).

The bidder must submit details of equipments as per **Form B** along with documentary proof. If bidder failed to deploy equipments/machineries within mobilisation period as mentioned in the tender documents, WAPCOS is free to terminate the contract at any time & forfeit the Bank Guarantee and blacklist the bidder.

Bidder has to submit an undertaking to deploy the above machineries for which he participated in the bidding process.

1.2.6 Bidder will be required to deploy atleast one dedicated Service Engineer/ Project Engineer for DWLR cum operator at the Regional office Data Center for Operation of DWLR system and ensure seamless data transfer from remote DWLR stations to National Data Center through GSM/GPRS network & then to India WRIS/WIMS software through internet. The processed data from India WRIS/WIMS in the form of reports/ bulletins will be transmitted to Regional & National Data Centre as per technical specifications. The undertaking for employment of these ground water professional be given.

1.2.7 Bidders will be required to deploy at least 5 rigs for the package along with submersible pumps of various capacities, ancillaries equipments tools accessories required for construction of well and over pumping as mentioned in the Annexure V, Scope of Work and Technical specification. An undertaking in this regard should be submitted in the technical Bid.

1.2.8 Bid Capacity The bidder should possess the bidding capacity as calculated by the specified formula. The formula generally used is:
Available bid capacity = $A \times 1.5 \times N - B$,

where A = Maximum value of engineering (Civil/ Electrical/ Mechanical as relevant to work being procured) works executed in any one year during the last five years (updated at the current price level), taking into account the completed as well as works in progress.

N = Number of years prescribed for completion of the work in question. B = Value (updated at the current price level) of the existing commitments and ongoing works to be completed in the next 'N'

years.

1.2.9 Average annual financial turnover during the last three years, ending 31st March 2024 of the previous financial year should be at least 50% of the estimated cost. (Balance Sheet duly audited and certified by Chartered Accountant) Note: In case of last financial year Bidder may submit the Provisional Balance Sheet duly signed by CA.

1.2.10 The bidder should have experience of having successfully completed similar works during last 7 years ending last day of month previous to the one in which tenders are invited:

(i) Three similar completed works costing not less than the amount equal to 40% of the (estimated cost of PART-A of the Tender i.e for construction PZ part if similar work is Type-1 nature) or (estimated cost of PART-B of the Tender i.e for the DWLR part if similar work is Type-2 nature)

or

Two similar completed works costing not less than the amount equal to 50% of (estimated cost of PART-A of the Tender i.e for construction PZ part if similar work is Type-1 nature) or (estimated cost of PART-B of the Tender i.e for the DWLR part if similar work is Type-2 nature)

or

One similar completed work costing not less than the amount equal to 80% of the (estimated cost of PART-A of the Tender i.e for construction PZ part if similar work is Type-1 nature) or (estimated cost of PART-B of the Tender i.e for the DWLR part if similar work is Type-2 nature)

(j) Definition of Similar works:

Types of Similar works are defined as:

Type-1: Any work in which drilling for exploration/exploitation of natural resources is component of scope of work

Type-2: Supply/Installation/commissioning/Maintenance of Digital Water Level Recorder.

(k) The value of the executed work shall be brought to the current costing level by enhancing the actual value of works at simple rate of 7% per annum calculated from the date of completion to last date of submission of bid.

(l) The tenderer shall submit details of works executed by them in last 7 years for qualification of work experiences criteria, documentary proof such as completion certificate & other documents from client clearly indicating the nature/scope of work, contract number, contract amount and actual date of completion, of such works. Rig deployment /copy of work order cannot be considered as work completion. Work completion certificate or part completion certificate is to be submitted.

(m) In case the work is done for private/ Government clients, details as per Form at Sl.No.C-(a) & C-(b) of Form C are to be submitted. Documents are to be submitted. Documents establishing receipt of payment for such works are to be submitted. For this purpose, TDS certificate or Form 26 AS of Income Tax department or copy of Bank statement or any other document clearly indicating name of organisation making payment, amount of payment shall be submitted.

(n) The tenderer or their DWLR OEM/authorized Suppliers as specified in ITB Clause 1.2.4 should have supplied and commissioned at least 10 % of the Digital Water Level Recorders stations with GSM / GPRS based telemetry during previous 7 (Seven) Financial years to Central Government/ State Government Departments or Public Sector Undertakings or any Project/ any other Public/ Private Customers in India. Note: The proof of supply as per supply order along with Commissioning/ Installation / Performance report/certificate in respect of successful commissioning.

(o) The bidder should have after sales support in the region (within a radius of 500 km from the State Capital) for Digital Water Level Recorders stations with GSM / GPRS based telemetry. If bidder does not have any after sales support office within 500 km from state Capital at the time of bidding, he shall be required to establish the same within one month after successful award of contract.

(p) The bidder shall submit the product brochure/literature, compliance statement duly signed by the bidder and other supporting document if any to establish the claim that the offered equipment meets the technical specifications provided in tender document. If there is any deviation in specification it should be mentioned in separate column of compliance statement.

1.2.11 The bidder must submit an undertaking for carrying out chemical analysis of water samples from any NABL accredited lab/labs. The Lab/labs shall have combined capacity of analyzing at least 300 water samples in a month.

1.2.12 Well construction Experience

“They must have drilled/completed wells to a depth of at least 75 m. Number of such wells should not be less than 10% of number of wells to be constructed in the Tender during previous 7 (Seven) Financial years for Central Government/ State Government Departments or Public Sector Undertakings or any Project/ any other Public/ Private Customers in India.”

1.2.13 a.) Bidder should have registered for GST (provide GSTIN certificate).

b.) The bidder should be register in the state for GST in which the work is to be taken up and shall submit the GST registration certificate.

	<p>If the bidder has not obtained the GST registration in the state in which the work is to be taken up or as required by GST authorities then in such case the bidder shall scan and upload following undertaking along with bid document.</p> <p>“If the work is awarded to me, I/We shall obtain GST registration certificate of the state in which work is to be taken up within one month from the date of receipt of award letter or before release of any payment by WAPCOS Ltd., whichever is earlier, falling which I/ We shall be responsible for delay in payment which will be due towards me /us on account of work executed and/ or for any action taken by WAPCOS or GST Department in this regard.</p> <p>1.2.14 The bidder should not have incurred any loss (profit after tax should be positive) in more than two year during available last five consecutive balance sheets, duly certified and audited by the chartered accountant. Yearly Turnover and audited balance sheet for last 5 years ending the financial year 2023-24 duly certified by chartered accountant should be submitted. Any such certificate must carry the UDIN (Unique document identification number).</p> <p>1.2.15 Bidder must not be black listed or debarred by any Government organization. Bidder should disclose their litigation history, if any. Both documents should be supported with an affidavit duly certified by notary.</p> <p>1.2.16 Bidder should have a solvency equal to 40% of estimated cost. The bidder must submitted original Solvency certificate to WAPCOS office before due date. Bidder must provide the name, designation, power of attorney with valid official email id and contact number of issuing Bank Authority of solvency certificate. Solvency Certificate must have been issued after the date of publication of NIT & be addressed to the tendering authority quoting the name of the work. The Solvency Certificate should not be dated beyond the last date of submission of the bids.</p>	
--	--	--

Signature of Bidder

Note:

The bidders should put serial numbers on all the pages and attest all pages as per checklist before uploading on the portal.

Bidders will be responsible if their bid becomes non responsive due to submission without page numbers as per checklist.